



14845 SW Murray Scholls Dr.
 Suite 110 PMB 306
 Beaverton, OR 97007
 Phone: 503-564-4178

Approved For State of California
 Factory Built Housing

By
 MA Consulting & Engineering MACE, LLC.
 Third Party Design Approval Agency (DAA)
 Certificate Number: DF1570823

These plans have been approved pursuant to the provisions of The State of California Health and Safety Code, Division 13, Part 6 and California Code of Regulations, Title 25, Chapter 3, Subchapter 1
 Approval herein does not authorize or approve any omission or deviation from State laws or valid local ordinances nor it is applicable to movement of units over highways, county roads or city streets.

Generic Foundation Design Approved

Occupancy	Roof LL	Wind	Exp	Seismic Cat
R3	30 psf	115	C	E

Plan Approval No. MAC-FBH 10153

By: *Mohsen Anis*

Approval Date: 5/26/2025

Expiration Date: 1/11/2028

5-20-25

STRUCTURAL CALCULATIONS

BOXABL

ACCESSORY DWELLING UNIT

MODEL BXB-000012

CALIFORNIA DEPT. OF HOUSING AND COMMUNITY DEVELOPMENT

FACTORY-BUILT MODULAR HOUSING PERMIT



5-20-25

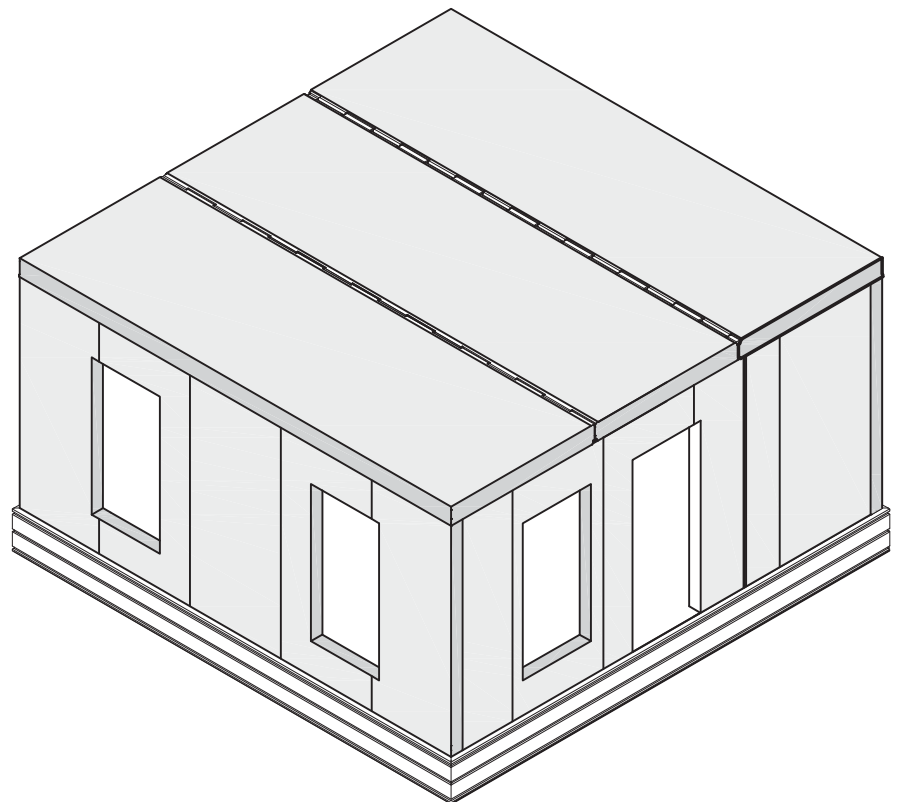

Copyright © 2004
 SIP Engineering Consultants, LI
 All Rights Reserved

AS INSTRUMENTS OF SERVICE, THESE CALCULATIONS SHALL REMAIN THE PROPERTY OF SIP ENGINEERING CONSULTANTS, LLC WHO SHALL RETAIN ALL COMMON LAW, STATUTORY & OTHER RESERVED RIGHTS, INCLUDING COPYRIGHTS. REPRODUCTION OR DISTRIBUTION IS PROHIBITED WITHOUT THE EXPRESSED, WRITTEN PERMISSION OF SIP ENGINEERING CONSULTANTS, LLC.

DESIGN CRITERIA :

LOCATION :

CA

CODE: 2022 CBC

SOLAR PANELS ? N

ROOF TRUSSES : N

PMRV ? N

UNIFORM LOADS :

GROUND SNOW LOAD :	40	psf (SEIS. CAT. A,B,C)
	40	psf (SEIS. CAT. D,E)

WALL HEIGHT = 9.5 ft

EXPOSURE FACT., Ce = 1

ROOF LIVE LOAD : 20 psf

ASCE 7-16 7.3 (7.3-1)

SIP ROOF DEAD LOAD : 6 psf

FLOOR LIVE LOAD : 40 psf

ROOF SL = .7 Pg Ce = 28 psf (SEIS. CAT. A,B,C)

FLOOR DEAD LOAD : 6 psf

STUCCO, HARDI PANEL (PAN) = 28 psf (SEIS. CAT. D,

TOTAL WALL DEAD LOAD : 5 psf

PLANK (PLK), NONE ? N

CARPORT ? Y

SIP WALL DEAD LOAD : 5 psf

roof (psf) wall psf psf

MASS OF ROOF + UPPER HALF OF EAVE WALLS = 7.6 + 3 = 10.1

(DIVIDED OVER ROOF AREA)

FLOOR STEEL WT = 1036 lb

SEISMIC MASS OF END WALL = 906 lb

ROOF STEEL WT = 561 lb

SEISMIC MASS OF FLOOR = 3202 lb

SHIPPING WT = 13,000 lb

SIP SHELL WEIGHT = 9,098 lb

INTERIOR FIXTURE MASS = 3,902 lb (for F2 calc)

LATERAL LOADS :

TOTAL MASS = 13,000 lb

ULT. NOM.

WIND SPEED :	120	93	mph Exposure C	→	qh = 16.0 psf
	147	114	mph Exposure B	→	qh = 16.0 psf

SEISMIC : I = 1

S1 = 0.782

SD1 = 0.89

Default Site Class = D

D,E = 0.20

Sms = 3.30 = FaSs

A,B,C = 0.56

Fv = 1.7

Sds = (2/3) SMS = 2.20

Fa = 1.2

Ss = 2.75

R = 6.5

Seis. Design Cat. = E

Seis. Force Resist. = Shear Panels of
System of Casita steel sheets & mgo

Analysis Procedure = Equiv. Lateral Force



SEISMIC FORCE CALCULATION

STORIES **1**

$$C_s = \frac{S_{DS}}{(R/I)} = \frac{2.20}{6.5} = 0.338 \quad (12.8-2)$$

PERIOD

$$T = C_t (h_n)^X$$

$$T = (.02)(10.5')^{3/4} = 0.12 < 1.5 T_s = 0.60$$

$T_s = 0.40$

GROUND MOTION HAZARD ANALYSIS NOT REQUIRED
ASCE 7-16 11.4.8 Exception 2

$$\text{SEISMIC FORCE} = C_s W p = 3.4 \text{ psf}$$

$$= 2.4 \text{ psf (Allow. Stress.)}$$

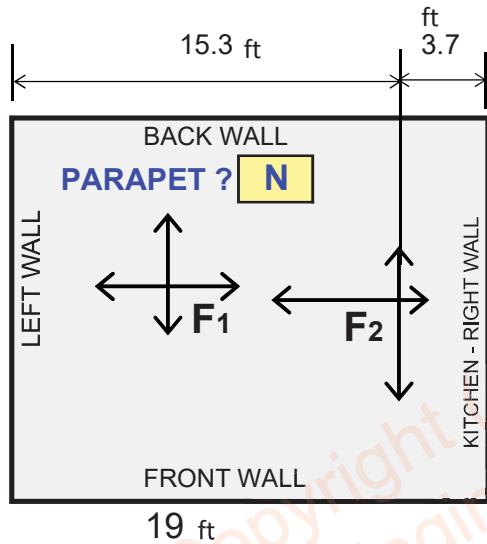

BASE SHEAR = 3,080 lb (ASD)

F2 includes interior fixture mass

ROOF DIAPHRAGM SHEAR = 51 plf < 350 lb allow.

OK

$$F_1 = 2.4 \text{ plf (19)} = 46 \text{ plf (SEISMIC, BUT USE ADJUSTED VALUE BELOW)}$$

$$= 17.6 \text{ psf (5.75)} = 101 \text{ plf (WIND AT ROOF LEVEL)}$$

$$= 17.6 \text{ psf (5.4)} = 94 \text{ plf WIND AT FLOOR LEVEL}$$

ROOF F2 = 389 lb

FLOOR F2 = 535 lb

SEISMIC REACTION AT MID-HT OF WALL

$$= 46 (19' / 2) + (.5) 906 (0.34) .7 \text{ ASD}$$

$$= 547 \text{ lb} \quad C_s$$

LOAD IN LINE WITH WALL

$$F_1 \text{ BOT. HALF OF WALL} = 107 \text{ lb}$$

F1 seis AT ROOF LEVEL ADJUSTED TO INCLUDE SEIS. LOAD OF ENDWALL

$$= 58 \text{ plf}$$

F1seis of GROUND FLOOR + BOT. HALF OF ALL 4 WALLS = 1188 lb



LATERAL WIND LOAD CALCULATIONS PER ASCE 7-16 SECTION 27.3.1

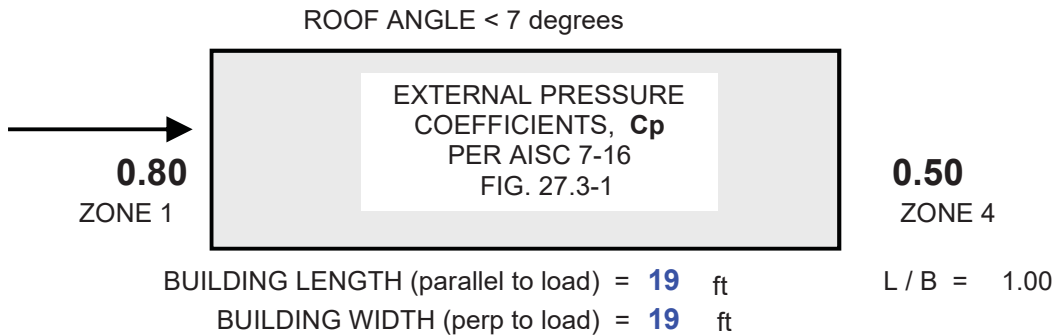

ULT. WIND SPEED = **120** MPH

EXPOSURE = **C**

ROOF HT = **10.75** Ft

WALL HT = **9.5** Ft

$k_h = 0.85$

$k_z = 0.85$

$k_{zt} = 1.00$

$k_d = 0.85$

$k_e = 1.00$

$V = 120$

$I = 1$

(ASD) $q_h = (.6) .00256 k_h k_{zt} k_d k_e V^2 I = 16.0$ psf

(ASD) $q_z = (.6) .00256 k_z k_{zt} k_d k_e V^2 I = 15.9$ psf

WIND PRESSURE, $p = q G C_p$ $G = 0.85$



ZONE	1	2			absolute value	absolute value Gcp	effective wind area
PRESSURE (psf)	10.8	6.8	=	17.6	PSF		
LEEWARD COMPONENT WALL LOAD = $q_h (G C_p + .18) .9$				17.5	psf	1.04	45 ft
LEEWARD COMPONENT WALL LOAD AT CORNERS =				20.6	psf within 3'	1.25	28 ft
WINDWARD COMPONENT WALL LOAD AT CORNERS =				16.1	psf within 3'	0.94	28 ft

WHOLE UNIT OVERTURNING MOMENT = 19,169

WHOLE UNIT RESISTING MOMENT = 74,100

RATIO = 3.866

LATERAL WIND LOAD CALCULATIONS PER ASCE 7-16 SECTION 27.3.1

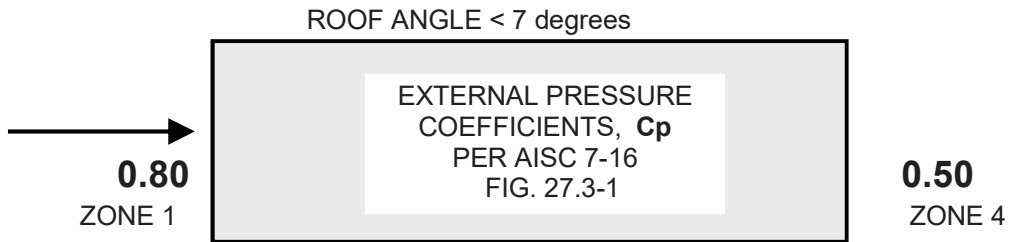

BUILDING LENGTH (parallel to load) = **19** ft L / B = 1.00
 BUILDING WIDTH (perp to load) = **19** ft

ULT. WIND SPEED = **146.5** MPH

EXPOSURE = **B**

ROOF HT = **10.75** Ft

WALL HT = **9.5** Ft

kh = 0.57

kz = 0.57

kzt = 1.00

kd = 0.85

ke = 1.00

V = 147

I = 1

(ASD) $q_h = (.6) .00256 k_h k_{zt} k_d k_e V^2 I = 16.0$ psf

(ASD) $q_z = (.6) .00256 k_z k_{zt} k_d k_e V^2 I = 16.1$ psf

WIND PRESSURE, $p = q G C_p$ $G = 0.85$



ZONE	1	2			absolute value	absolute value	effective wind area
PRESSURE (psf)	10.9	6.8	=	17.7	PSF	Gcp	
LEEWARD COMPONENT WALL LOAD = $q_h (G C_p + .18) .9$				17.5	psf	1.04	45 ft
LEEWARD COMPONENT WALL LOAD AT CORNERS =				20.5	psf within 3'	1.25	28 ft
WINDWARD COMPONENT WALL LOAD AT CORNERS =				16.1	psf within 3'	0.94	28 ft

UPLIFT ANALYSIS

ROOF DEAD LOAD : **6.0** psf

COMPONENT ROOF LOAD = $qh (GC_p + .18)$

C & C - EFFECTIVE WIND AREA : **120** sq ft.



	ft	6.45	3.15	0	3.15	6.45
		zone 2	zone 1	zone 1'	zone 1	zone 2
C & C - GC _p :		1.77	1.27	0.88	1.27	1.77
UPLIFT PRESS. (psf) :		31.2	23.2	16.9	23.2	31.2

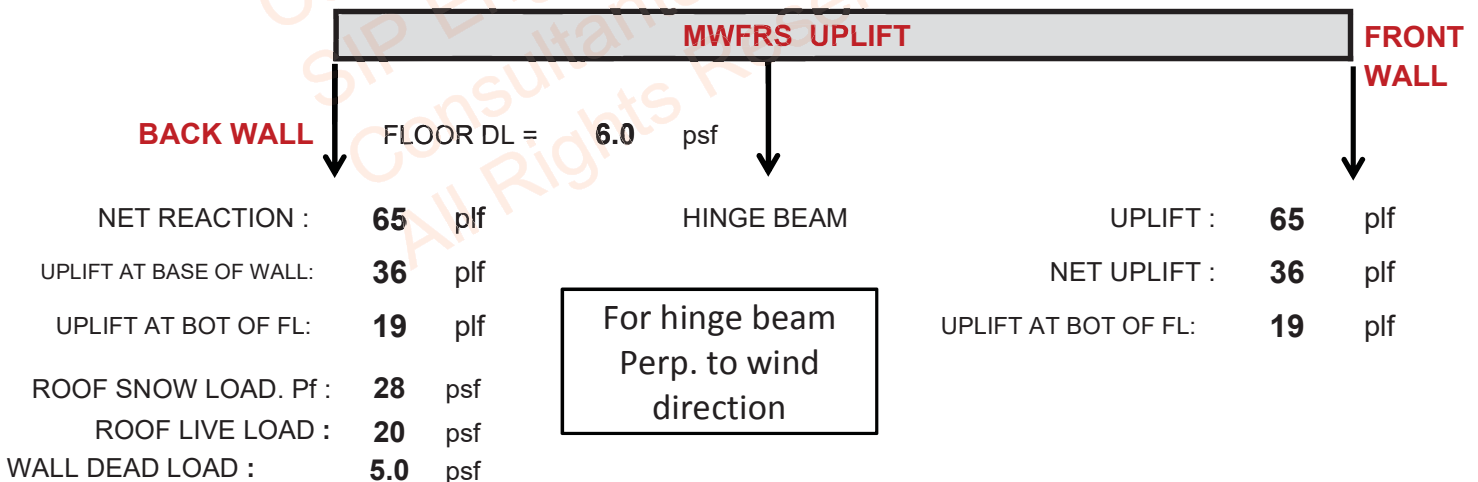
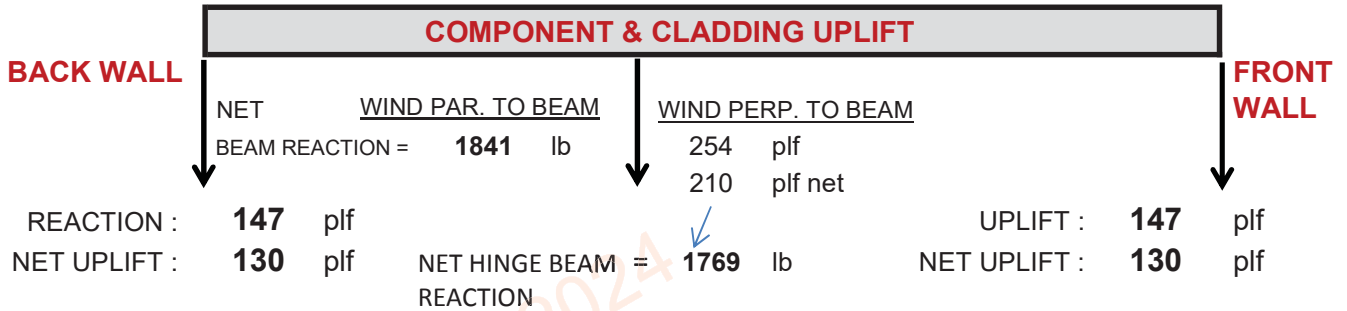

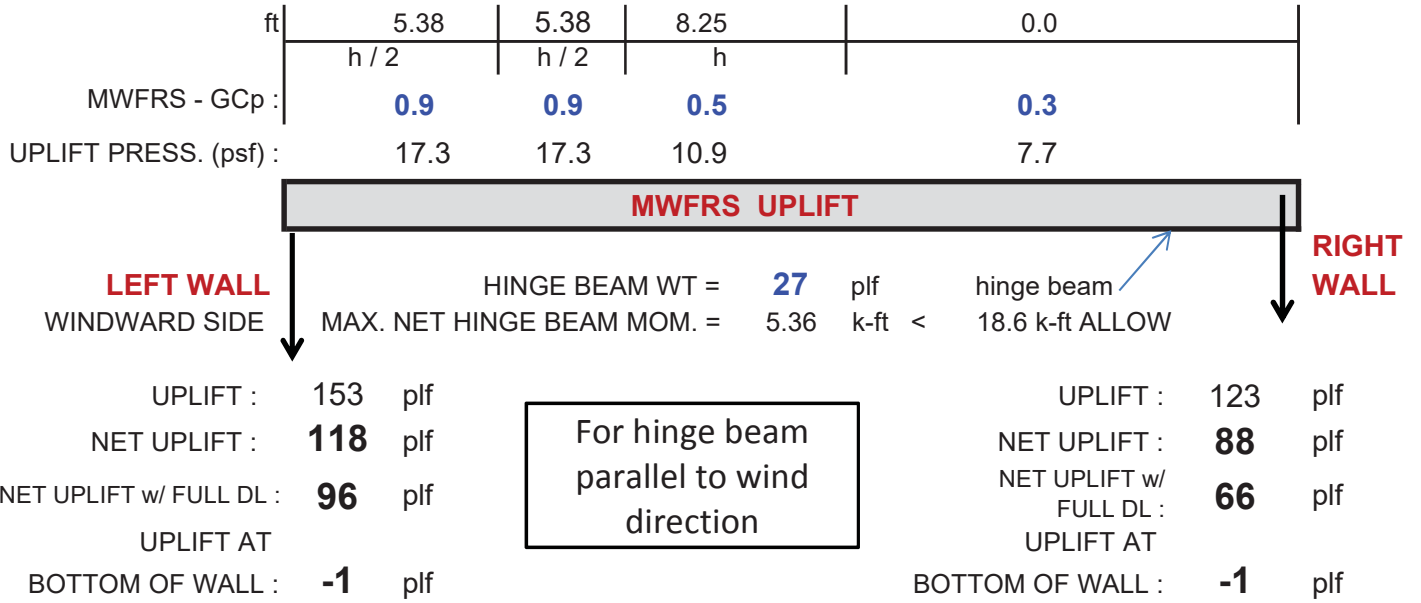

HINGE BEAM TRIB. WIDTH = **9.3** ft

trib resisted by wall

$$\text{NET UPLIFT REACTION AT ENDS OF ROOF HINGE BEAMS USING 60\% DL} = \left(\begin{matrix} \text{plf} \\ [118] \end{matrix} - \begin{matrix} \text{psf} \\ 17.3 \end{matrix} \left[\begin{matrix} \text{ft} \\ 2 \end{matrix} \right] \right) \left[\begin{matrix} \text{ft} \\ 9.3 \end{matrix} \right]$$

trib resisted by wall

$$= 779.28 \text{ lb}$$

NET UPLIFT REACTION - 1/2 BEAM WT (.6) = **625** lb

$$\text{WIND ONLY UPLIFT REACTION AT ENDS OF ROOF HINGE BEAMS} = \left(\begin{matrix} \text{plf} \\ [153] \end{matrix} - \begin{matrix} \text{psf} \\ 17.3 \end{matrix} \left[\begin{matrix} \text{ft} \\ 2 \end{matrix} \right] \right) \left[\begin{matrix} \text{ft} \\ 9.3 \end{matrix} \right]$$

$$= 1097.3 \text{ lb}$$

WIND ONLY UPLIFT REACTION OVER 6.5' EFFECTIVE WIDTH = 203 plf

AVE. WIND PRESSURE TRIBUTARY TO HINGE BEAM

= 15.0 psf

(MWFRS)

$$\text{NET UPLIFT LOAD ON HINGE BEAM} = \left(15.0 - 0.6 \left[6 \right] \right) \left[9.3 \right]$$

$$= 106 \text{ plf}$$

MAX. NET MOMENT ON HINGE BEAM = **4.42** k-ft (MWFRS)

$$\text{UPLIFT REACTION AT ENDS OF ROOF HINGE BEAMS} = \left[106 \right] \left[9.3 - 2.0 \right]$$

$$= 771 \text{ lb}$$

trib resisted directly by walls

UPLIFT REACTION - 1/2 BEAM WT (.6) = **617** lb



For hinge beam perpendicular to wind direction

Copyright (c) 2024
SIP Engineers, LLC
All Rights Reserved

RIGHT WALL

FLOOR ANCHORS TO: CONCRETE w/ VERT. PL



SEISMIC SHEAR = $\frac{\text{from roof F2}}{313} + 58 (19'2) = 860 = 57$ plf cap. **O.K.**

At bot. of wall controls.
Windows accounted for in wall test.

WIND SHEAR = $101 (19'2) = 962 = 64$ plf cap. **O.K.**

- UPLIFT/LATERAL CAP. OF UPPER #10 ROW ON UPPER PL = 740 lb
- LATERAL CAP. OF LOWER #10 ROWS OF UPPER PL = 422 lb
- UPLIFT CAP. OF LOWER #10 ROWS ON UPPER PL = 1,295 lb
- TOTAL TITEN SCREW UPLIFT CAPACITY OF LOWER PL = 1,317 lb
- TOTAL TITEN SCREW HORIZ. CAPACITY OF LOWER PL = 717 lb
- TOTAL WOOD SCREW UPLIFT & SHEAR CAP. OF LOWER PL = 1491 lb
- TOTAL HORIZ. CAP. OF WALL-TO-FL TOE SCREWS = 1,685 lb
- % OF TOE SCREW LATERAL CAPACITY USED = 20 %

- UPLIFT LOAD PER UPPER PL = 435 lb
- LATERAL LOAD PER UPPER PL = 79 lb
- UPPER ROW OF UPPER PL RESULT. LOAD = 442 lb < 740 lb

FORCE TRANSFER AROUND OPENING METHOD	
PER WALL w/ OPEN.	TOTAL WIND CAP. = 3474 lb
TEST x 2	TOTAL SEISMIC CAP. = 1264 lb

UPPER BOXABL SHEAR PL'S REQ'D = 1.5 USE [8]
INTERACTION RATIO OF LOWER SCREWS OF UPPER PL = 0.52
LOWER SHEAR PL'S REQ'D FOR WOOD SCREW SHEAR = 1.3 USE [5]
LOW. H.D. PL TOT. RESULT. WOOD SCREW SHEAR = 550 lb
INTERACTION RATIO OF LOW. PL TITEN SCREWS = 0.83

ABOVE INTERACTION RATIOS INCLUDE SHEAR & UPLIFT FORCES

WIND
 Holddown = $962 \left(\frac{18.4 \text{ ft}}{9.5} \right) + 3 \left(\frac{19}{2} \right) \left(\frac{9}{2} \right) - 3 \left(\frac{2.5}{9} \right) \left(\frac{9}{2} \right)$
 Force = 18.4 ft psf perp. trib par. trib
 - (3 psf)(9.5')(3') = 86 lb
 WALL WT AROUND CORNER
 this value incl floor weight → 435 lbs → 401 lbs

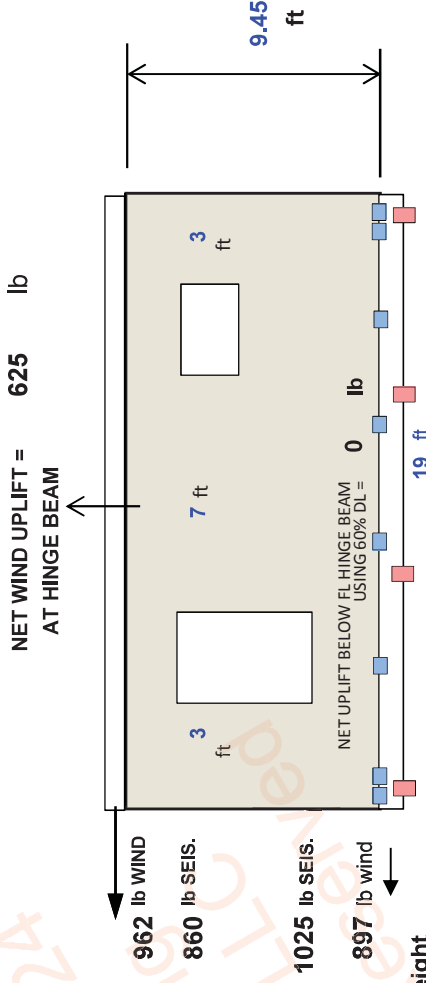

NET UPLIFT BELOW FL HINGE BEAM USING 60% DL = 0 lb

UPLIFT LOAD DISTRIBUTED OVER 8 " IN LVL RIM
 CROSS-GRAIN TENSION CAP. OF LVL = 770 lb > 435 lb

HOLDDOWN REQ'TS BOTH CORNERS
 [1] UPPER PLATES → use [1] [435 lb ea]
 [1] LOW. PLATES → use [1] [401 lb ea]

REAR WALL

FLOOR ANCHORS TO : CONCRETE w/ VERT. PL

SEISMIC LOAD = $\frac{F_2/2}{195} + 58$ (19'2) = 741 lb

WIND LOAD = 101 (19'2) = 962 lb

% OF TOE SCREW LATERAL CAPACITY USED = 50 %

SEE "SIDE WALLS" CALC FOR FASTENER CAPACITIES

	6' WALL	7.5' WALL
UPLIFT LOAD PER UPPER PL =	266	483
LATERAL LOAD PER UPPER PL =	16	54
UPPER ROW OF UPPER PL RESULTANT LOAD =	266	486
TOTAL SHEAR CAP. OF WALL-TO-FL TOE SCREWS =	599	702
# UPPER BOXABL SHEAR PL'S REQ'D =	0.2	0.5
# UPPER BOXABL SHEAR PL'S USED =	6	4
INTERACTION RATIO OF LOW. SCREWS OF UP. PL =	0.24	0.50
# LOWER SHEAR PL'S REQ'D FOR WOOD SCREW SHEAR =	0.6	0.7
# LOWER PLATES USED =	4	4
LOW. H.D. PL TOT. RESULT. WOOD SCREW SHEAR =	431	521
INTERACTION RATIO OF LOW. PL TITEN SCREWS =	0.58	0.70

LEFT WALL

Holddown Force = $\frac{394 (9.5)}{5.5} + \frac{36}{\text{plf}} \left(\frac{6.4}{\text{Len}} / 2 \right) = 798$ lbs

RIGHT WALL

Holddown Force = $\frac{568 (9.5)}{6.5} + \frac{36}{\text{plf}} \left(\frac{7.5}{\text{Len}} / 2 \right) = 966$ lbs

RIGHT SIDE ASPECT RATIO CAPACITY ADJUSTMENT = 0.93

RIGHT SIDE WIND SHEAR CAP. = $0.93 (349) = 326$ plf

RIGHT SIDE SEIS. SHEAR CAP. = $0.93 (127) = 119$ plf

LEFT SIDE ASPECT RATIO CAPACITY ADJUSTMENT = 0.88

LEFT SIDE WIND SHEAR CAP. = $0.88 (349) = 307$ plf

LEFT SIDE SEIS. SHEAR CAP. = $0.88 (127) = 112$ plf

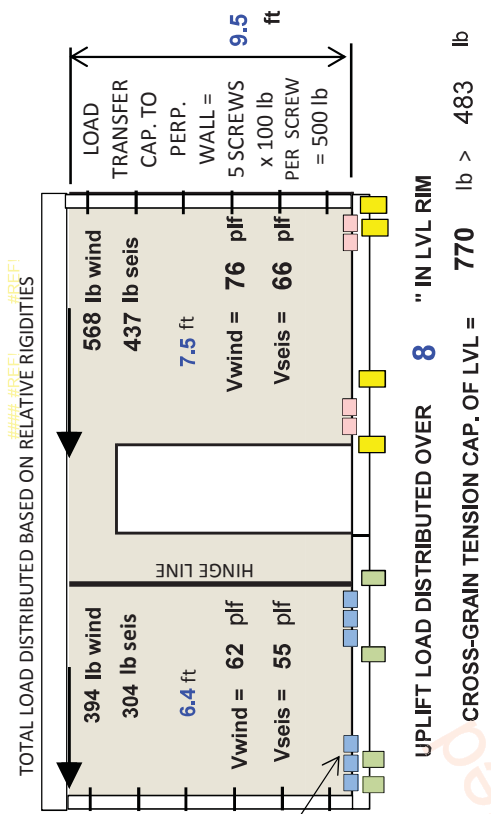

HOLDDOWN REQUIREMENTS

798 lbs → [2] UPPER PL use 3 [266 lb ea]

752 lbs → [1] LOW. PLATES use 2 [376 lb ea]

966 lbs → [2] UPPER PL use 2 [483 lb ea]

909 lbs → [2] LOW. PLATES use 2 [455 lb ea]

to satisfy interaction ratio

FRONT WALL

FLOOR ANCHORS TO : CONCRETE w/ VERT. PL

RIGHT SIDE ASPECT RATIO CAPACITY ADJUSTMENT = 0.81
RIGHT SIDE WIND SHEAR CAP. = $0.81 [349]$ = 283 plf
RIGHT SIDE SEIS. SHEAR CAP. = $0.81 [127]$ = 103 plf

SEISMIC LOAD = $\frac{F_2/2}{195} + 58 (19'2)$ = 741 lb

LEFT SIDE ASPECT RATIO CAPACITY ADJUSTMENT = 0.93
LEFT SIDE WIND SHEAR CAP. = $0.93 [349]$ = 326 plf
LEFT SIDE SEIS. SHEAR CAP. = $0.93 [127]$ = 119 plf

WIND LOAD = 101 (19'2) = 962 lb

% OF TOE SCREW LATERAL CAPACITY USED = 50 %

SEE "SIDE WALLS" CALC FOR FASTENER CAPACITIES

	LEFT WALL	RIGHT WALL
UPLIFT LOAD PER UPPER PL =	473	327 lb
LATERAL LOAD PER UPPER PL =	51	26 lb
UPPER ROW OF UPPER PL RESULTANT LOAD =	475	328 lb < 740 lb
TOTAL SHEAR CAP. OF WALL-TO-FL TOE SCREWS =	702	506 lb
# UPPER BOXABL SHEAR PL'S REQ'D =	0.5	0.4
# UPPER BOXABL SHEAR PL'S USED =	4	6
INTERACTION RATIO OF LOW. SCREWS OF UP. PL =	0.48	0.31
# LOWER SHEAR PL'S REQ'D FOR WOOD SCREW SHEAR =	0.7	0.6
# LOWER PLATES USED =	4	4
LOW. H.D. PL TOT. RESULT. WOOD SCREW SHEAR =	511	509 lb
INTERACTION RATIO OF LOW. PL TITEN SCREWS =	0.69	0.65

LEFT SIDE
 net uplift - .6(wall wt)
 Holddown Force = $\frac{553 [9.5]}{6.5} + \frac{36 \text{ plf}}{\left(\frac{7.5}{2}\right) \text{ Len}} - \frac{3 [4.75] \left(\frac{7.5}{2}\right) \text{ psf perp. trib par. trib}}{2} =$
 this value incl. floor wt (same as ceiling) → = 892 lbs → [2] LOW. PLATES use 2 [446 lb ea.]

RIGHT SIDE
 Holddown Force = $\frac{409 [9.5]}{4.4} + \frac{36 \text{ plf}}{\left(\frac{5}{2}\right) \text{ Len}} - \frac{3 [4.75] \left(\frac{5.4}{2}\right) \text{ psf perp. trib par. trib}}{2} =$
 this value incl. floor wt (same as ceiling) → = 922 lbs → [2] LOW. PLATES use 2 [461 lb ea.]



LEFT SIDE TESTED WIND LOAD CAPACITY = 1737 lb
 LEFT SIDE CAPACITY ADJUSTED FOR SEIS. = 632 lb

FORCE TRANSFER AROUND OPENING METHOD
 TOTAL LOAD DISTRIBUTED BASED ON RELATIVE RIGIDITIES

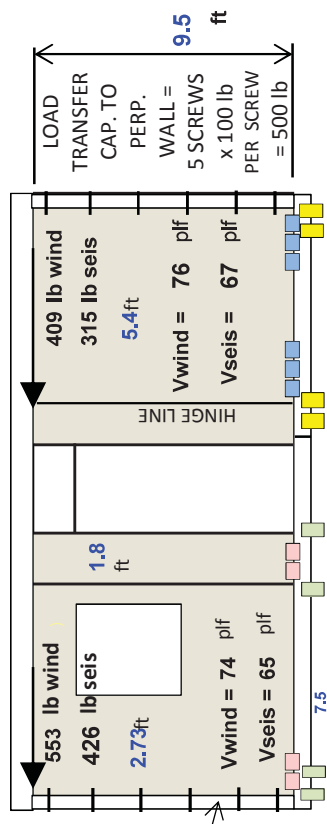

CROSS-GRAIN TENSION CAP. OF LVL = 770 lb > 473 lb
 UPLIFT LOAD DISTRIBUTED OVER 8 " IN LVL RIM

HOLDDOWN REQUIREMENTS
 945 lbs → [2] UPPER PL use 2 [473 lb ea.]
 892 lbs → [2] LOW. PLATES use 2 [446 lb ea.]

EXTRA PLATE ON RIGHT SIDE TO MATCH REQ'TS WHEN TRUSSES ARE USED

981 lbs → [2] UPPER PL use 3 [327 lb ea.]
 922 lbs → [2] LOW. PLATES use 2 [461 lb ea.]
 to satisfy interaction ratio

LEFT WALL



FLOOR ANCHORS TO : CONCRETE w/ VERT. PL

from roof F2

SEISMIC SHEAR = $\frac{76}{15.0} + 58 (19'2)$ = $\frac{622}{15.0}$ = **41** plf cap. O.K. < 127 plf cap.

At bot. of wall controls.

Windows accounted for in wall test.

WIND SHEAR = $\frac{101}{15.0} + 58 (19'2)$ = $\frac{962}{15.0}$ = **64** plf cap. O.K. < 349 plf cap.

SEIS. CATEGORY : E

UPLIFT LOAD PER UPPER PL = **435 lb**
 LATERAL LOAD PER UPPER PL = **30 lb**

UPPER ROW OF UPPER PL RESULT. LOAD = **436 lb** < 740 lb

FORCE TRANSFER AROUND OPENING METHOD	
PER WALL w/ OPEN TEST x 2	TOTAL WIND CAP. = 3474 lb
	TOTAL SEISMIC CAP. = 1264 lb

UPLIFT/LATERAL CAP. OF UPPER #10 ROW ON UPPER PL = 740 lb
LATERAL CAP. OF LOWER #10 ROWS OF UPPER PL = 422 lb
UPLIFT CAP. OF LOWER #10 ROWS ON UPPER PL = 1,295 lb
TOTAL TITEN SCREW UPLIFT CAPACITY OF LOWER PL = 1,317 lb
TOTAL TITEN SCREW HORIZ. CAPACITY OF LOWER PL = 717 lb

TOTAL WOOD SCREW UPLIFT & SHEAR CAP. OF LOWER PL = **1,491 lb**
 TOTAL HORIZ. CAP. OF WALL-TO-FL TOE SCREWS = **1,685 lb**
 % OF TOE SCREW LATERAL CAPACITY USED = **50 %**

UPPER BOXABL SHEAR PL'S REQ'D = 0.3 USE [4]
INTERACTION RATIO OF LOWER SCREWS OF UPPER PL = 0.41
LOWER SHEAR PL'S REQ'D FOR WOOD SCREW SHEAR = 1.2 USE [4]
LOW. H.D. PL TOT. RESULT. WOOD SCREW SHEAR = 506 lb
INTERACTION RATIO OF LOW. PL TITEN SCREWS = 0.80

ABOVE INTERACTION RATIOS INCLUDE SHEAR & UPLIFT FORCES

WIND
 Holddown = $\frac{962}{18.4 \text{ ft}} + 3 \left[\frac{19}{2} \right]$ = $\frac{962}{18.4} + 3 \left[\frac{19}{2} \right]$ = **435 lbs**
 Force = $\frac{962}{18.4 \text{ ft}} + 3 \left[\frac{19}{2} \right] - 3 \left[\frac{2.5}{2} \right]$ = $\frac{962}{18.4} + 3 \left[\frac{19}{2} \right] - 3 \left[\frac{2.5}{2} \right]$ = **401 lbs**
 - (3 psf)(9.5')(3') = 86 lb WALL WT AROUND CORNER

this value incl floor weight →

NET WIND UPLIFT = **625 lb**
 AT HINGE BEAM

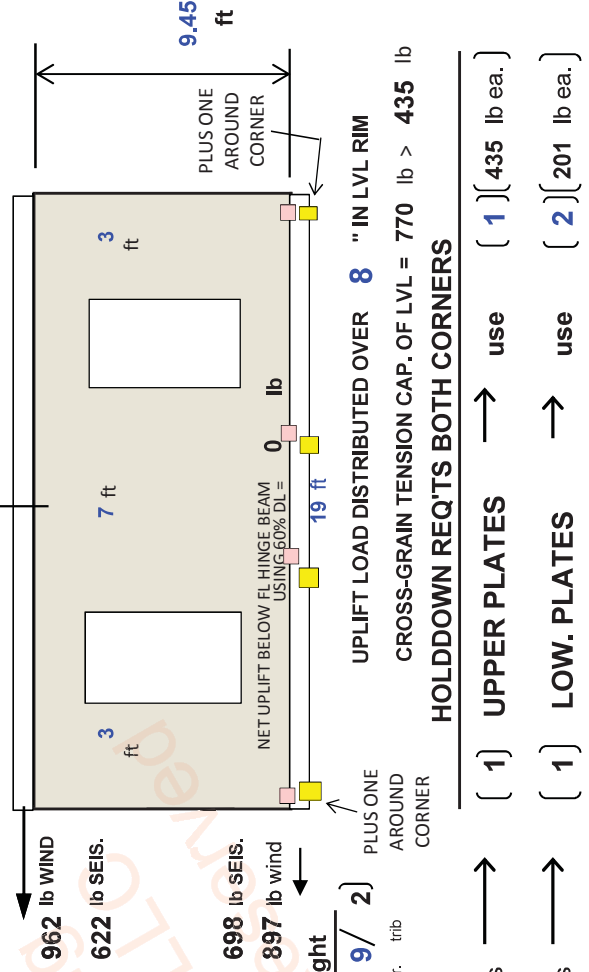

UPPER PLATES → use [1] (435 lb ea.)
 LOW. PLATES → use [2] (201 lb ea.)

OPENING CORNER FORCES & SHEAR ABOVE & BELOW OPENINGS

SIDE WALLS

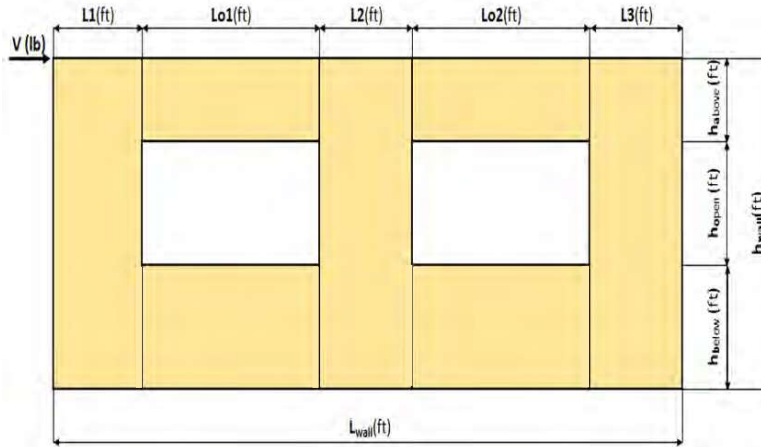

Shear Wall Calculation Variables

V	962 lbf	Opening 1		Opening 2		Adj. Factor Method = 2bs/h	
L1	3.25 ft	ha1	1.50 ft	ha2	1.50 ft	Wall Pier Aspect Ratio Adj. Factor	
L2	6.50 ft	ho1	6.00 ft	ho2	6.00 ft	P1=ho1/L1=	1.85 N/A
L3	3.25 ft	hb1	2.00 ft	hb2	2.00 ft	P2=ho2/L2=	0.92 N/A
h _{wall}	9.50 ft	Lo1	3.00 ft	Lo2	3.00 ft	P3=ho3/L3=	1.85 N/A
L _{wall}	19.00 ft						

1. Hold-down forces: $H = Vh_{wall}/L_{wall}$ 481 lbf

2. Unit shear above + below opening
 First opening: $va1 = vb1 = H/(ha1+hb1) = 137$ plf
 Second opening: $va2 = vb2 = H/(ha2+hb2) = 137$ plf

3. Total boundary force above + below openings
 First opening: $O1 = va1 \times (Lo1) = 412$ lbf
 Second opening: $O2 = va2 \times (Lo2) = 412$ lbf

4. Corner forces
 $F1 = O1(L1)/(L1+L2) = 137$ lbf
 $F2 = O1(L2)/(L1+L2) = 275$ lbf
 $F3 = O2(L2)/(L2+L3) = 275$ lbf
 $F4 = O2(L3)/(L2+L3) = 137$ lbf

5. Tributary length of openings
 $T1 = (L1 \times Lo1)/(L1+L2) = 1.00$ ft
 $T2 = (L2 \times Lo1)/(L1+L2) = 2.00$ ft
 $T3 = (L2 \times Lo2)/(L2+L3) = 2.00$ ft
 $T4 = (L3 \times Lo2)/(L2+L3) = 1.00$ ft

6. Unit shear beside opening
 $V1 = (V/L)(L1+T1)/L1 = 66$ plf
 $V2 = (V/L)(T2+L2+T3)/L2 = 82$ plf
 $V3 = (V/L)(T4+L3)/L3 = 66$ plf
 Check $V1 \times L1 + V2 \times L2 + V3 \times L3 = V?$ 962 lbf **OK**

7. Resistance to corner forces
 $R1 = V1 \times L1 = 215$ lbf
 $R2 = V2 \times L2 = 532$ lbf
 $R3 = V3 \times L3 = 215$ lbf

8. Difference corner force + resistance
 $R1 - F1 = 78$ lbf
 $R2 - F2 - F3 = -18$ lbf
 $R3 - F4 = 78$ lbf

9. Unit shear in corner zones
 $vc1 = (R1 - F1)/L1 = 24$ plf
 $vc2 = (R2 - F2 - F3)/L2 = -3$ plf
 $vc3 = (R3 - F4)/L3 = 24$ plf

OPENING CORNER FORCES & SHEAR ABOVE & BELOW OPENINGS

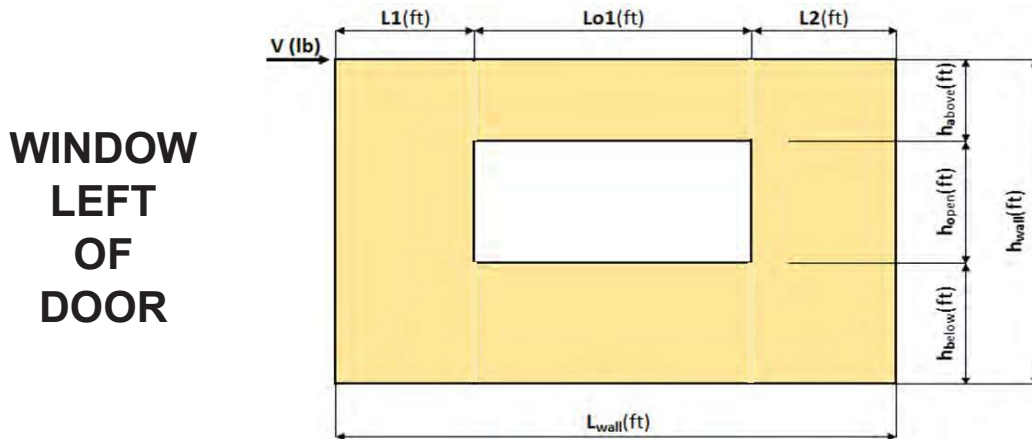

Shear Wall Calculation Variables

V	553 lbf	Opening 1		Adj. Factor Method =	2bs/h
L1	2.73 ft	ha1	1.50 ft	Wall Pier Aspect Ratio	Adj. Factor
L2	1.77 ft	ho1	6.00 ft	P1=ho1/L1=	2.20 0.975
h _{wall}	9.45 ft	hb1	1.95 ft	P2=ho2/L2=	3.39 0.826
L _{wall}	7.50 ft	Lo1	3.00 ft		

1. Hold-down forces: $H = Vh_{wall}/L_{wall} = 697 \text{ lbf}$

2. Unit shear above + below opening

First opening: $va1 = vb1 = H/(ha1+hb1) = 202 \text{ plf}$

3. Total boundary force above + below openings

First opening: $O1 = va1 \times (Lo1) = 606 \text{ lbf}$

4. Corner forces

$F1 = O1(L1)/(L1+L2) = 368 \text{ lbf}$

$F2 = O1(L2)/(L1+L2) = 238 \text{ lbf}$

5. Tributary length of openings

$T1 = (L1 \cdot Lo1)/(L1+L2) = 1.82 \text{ ft}$

$T2 = (L2 \cdot Lo1)/(L1+L2) = 1.18 \text{ ft}$

6. Unit shear beside opening

$V1 = (V/L)(L1+T1)/L1 = 123 \text{ plf}$

$V2 = (V/L)(T2+L2)/L2 = 123 \text{ plf}$

Check $V1 \cdot L1 + V2 \cdot L2 = V?$ 553 lbf **OK**

7. Resistance to corner forces

$R1 = V1 \cdot L1 = 336 \text{ lbf}$

$R2 = V2 \cdot L2 = 218 \text{ lbf}$

8. Difference corner force + resistance

$R1 - F1 = -32 \text{ lbf}$

$R2 - F2 = -21 \text{ lbf}$

9. Unit shear in corner zones

$vc1 = (R1 - F1)/L1 = -12 \text{ plf}$

$vc2 = (R2 - F2)/L2 = -12 \text{ plf}$

CORNER FORCES (FLAT ROOF CONDITION)

553 lb < 1,737 lb ALLOWABLE

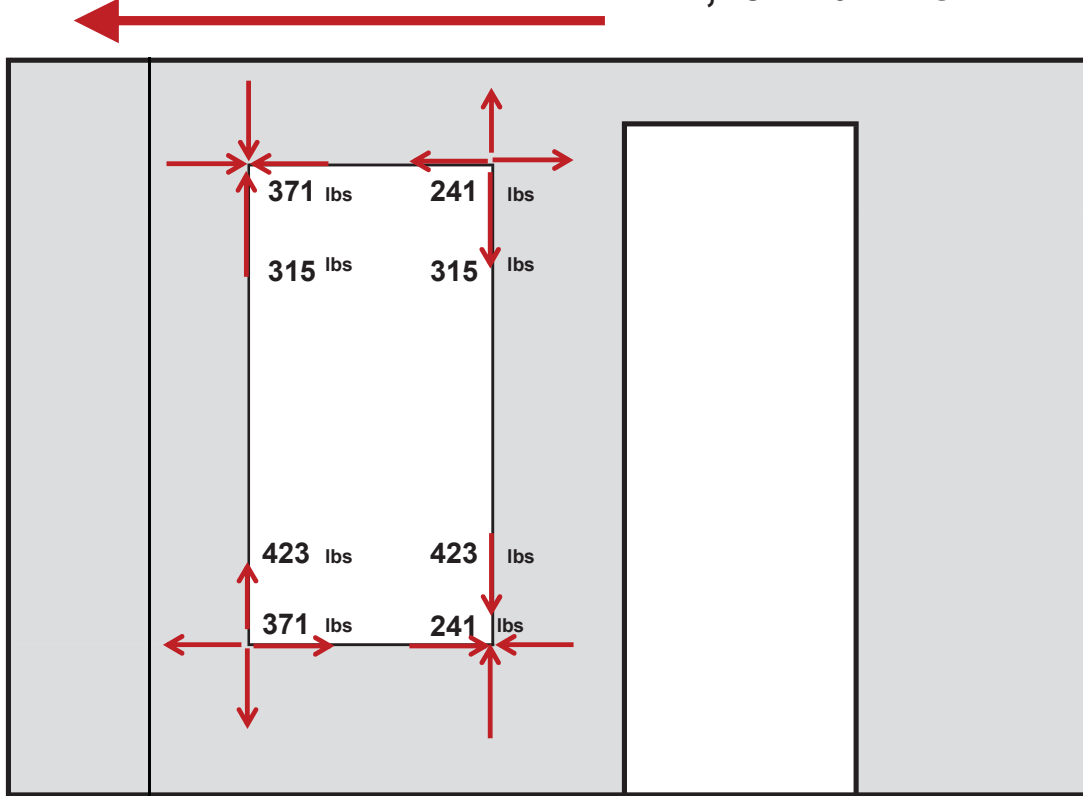

553 lb < 1,737 lb ALLOWABLE

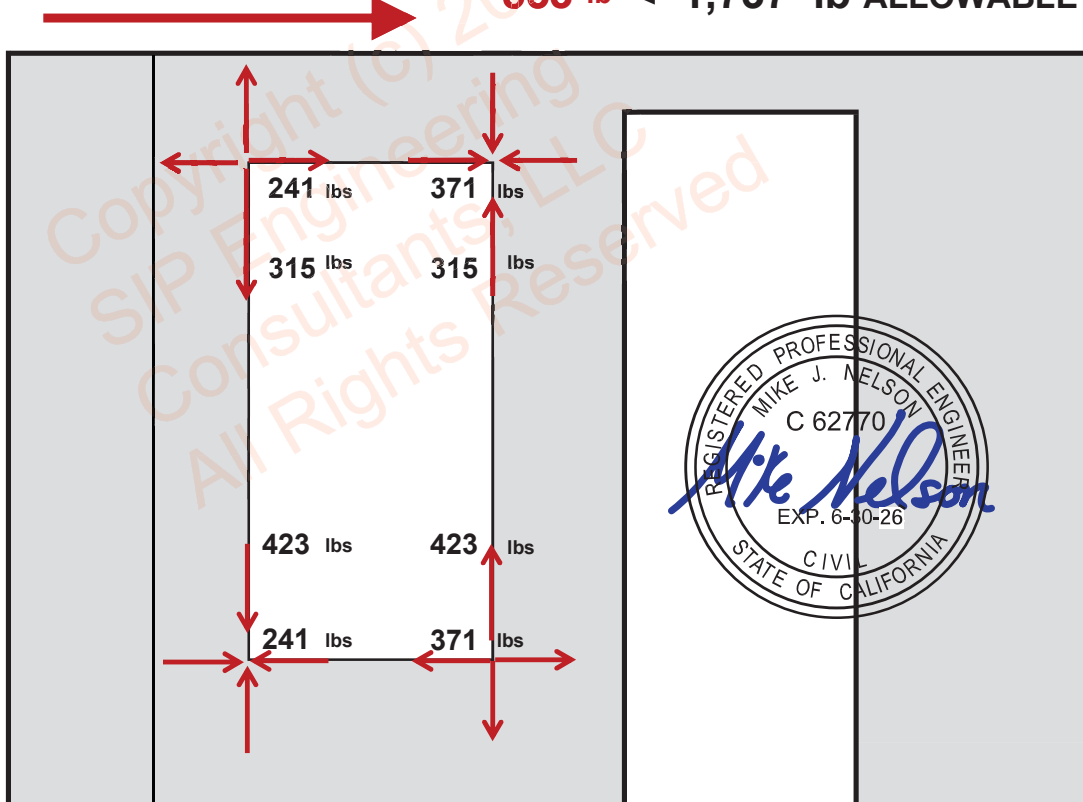

Racking Shear Wall Panel with Openings Load Test, ASTM E72-15, RADCO PROJECT # 236093.R

Load(lbs)	Deflection (in.)					Set (in.)				
	Panel #1 Steel 1	Panel #2 Steel 2	Panel #3 MgO 1	Panel #4 MgO 2	Average	Panel #1 Steel 1	Panel #2 Steel 2	Panel #3 MgO 1	Panel #4 MgO 2	Average
0	0.0000	0.0000	0.0000	0.0000	0.0000	0.0000	0.0000	0.0000	0.0000	0.0000
1000	0.0458	0.1620	0.0253	0.1056	0.0847	0.0013	-0.0054	-0.0040	-0.0071	-0.0038
2000	0.0764	0.2693	0.0629	0.1905	0.1498	0.0032	0.0002	-0.0004	-0.0019	0.0003
3000	0.1088	0.3784	0.0972	0.3006	0.2213	0.0065	0.0099	0.0031	0.0070	0.0066
4000	0.1511	0.5190	0.1364	0.4471	0.3134	0.0084	0.0190	0.0049	0.0141	0.0116
5000	0.2386		0.1847		0.2117	0.0223		0.0107		0.0165
6000										
Ultimate	5669	4825	5540	4814	5212.0					

↔ 5,212 / 3 = 1,737 lb ALLOWABLE

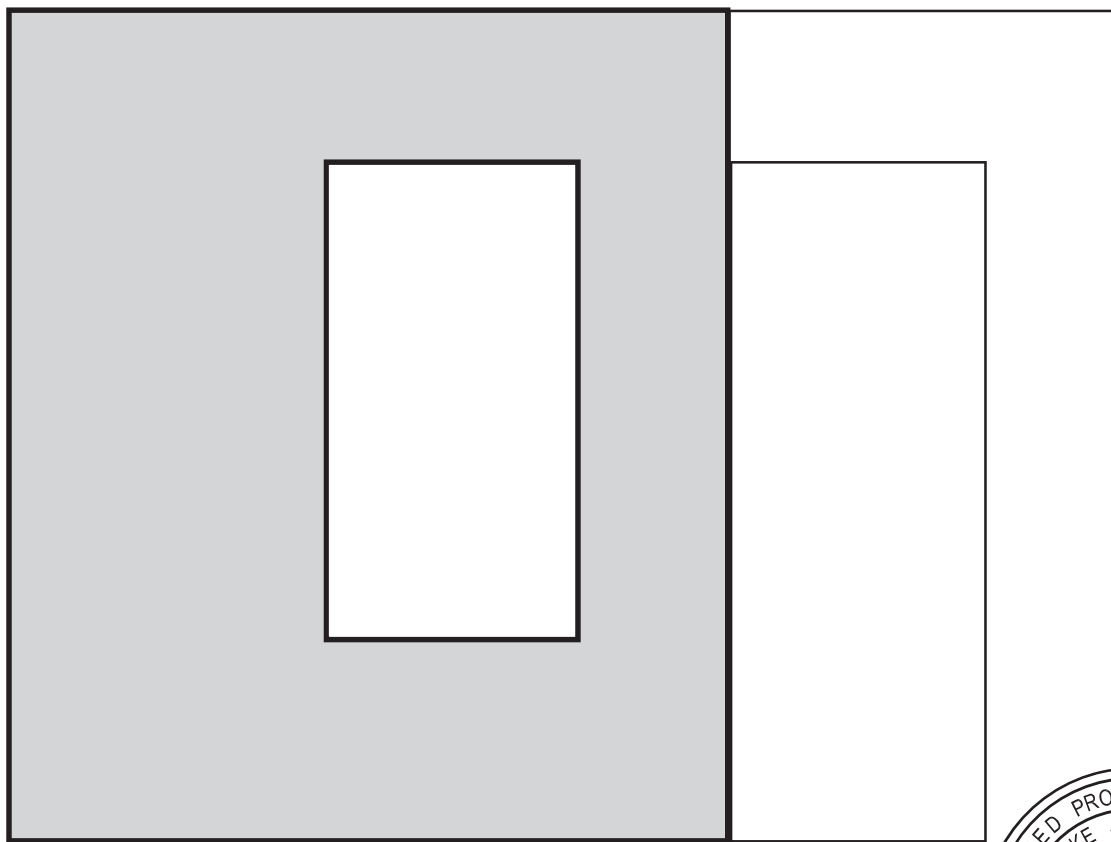



Racking Shear Single Panel Load Test, ASTM E72

- | | | |
|------------------|------------------|------------------|
| Panel #1 Steel 1 | Panel #2 Steel 2 | Panel #3 MgO 1 |
| Panel #4 MgO 2 | Panel #1 Steel 1 | Panel #2 Steel 2 |
| Panel #3 MgO 1 | Panel #4 MgO 2 | |

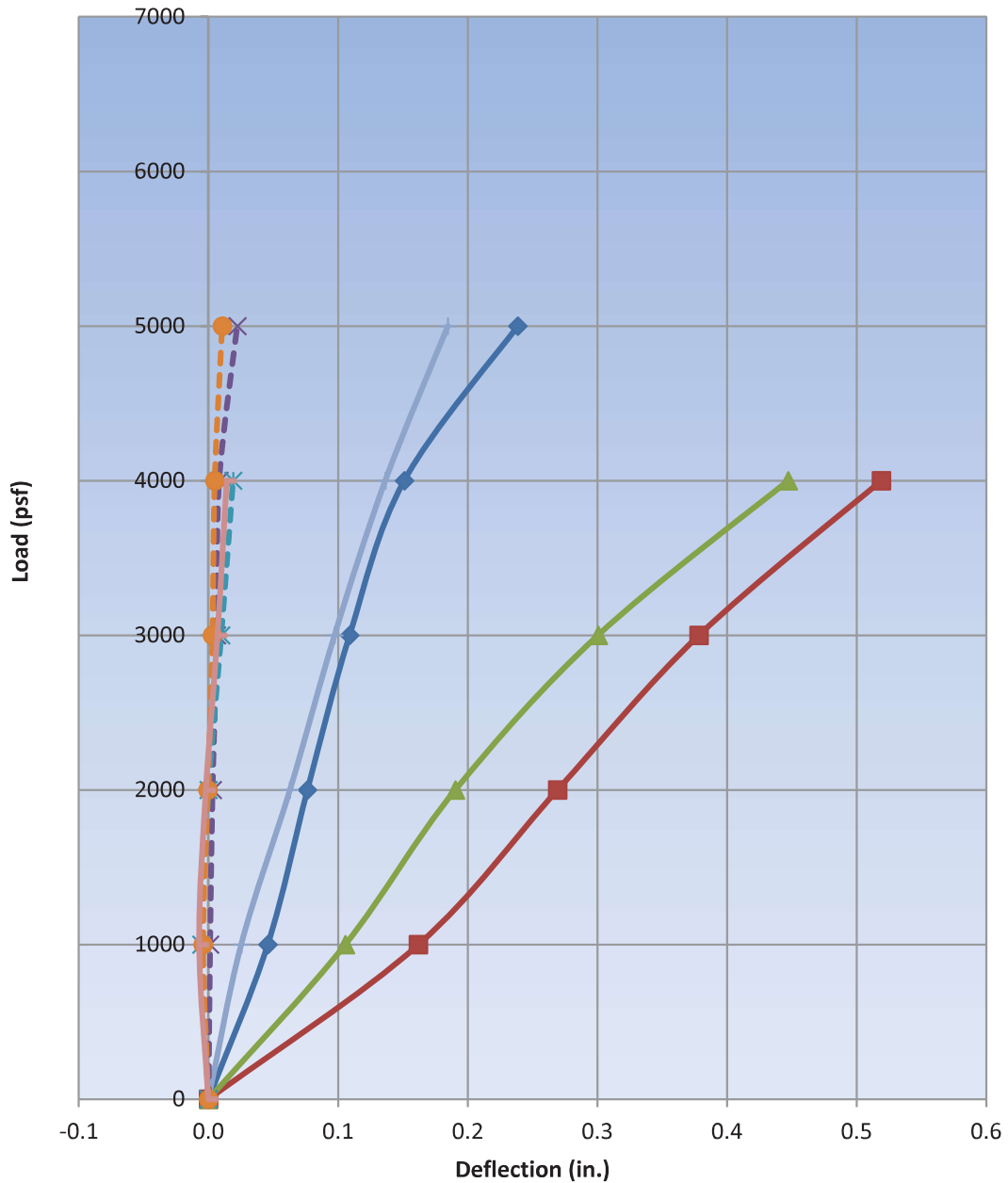

TENSION / BENDING ANALYSIS OF FLOOR EDGE AT HOLDDOWNS

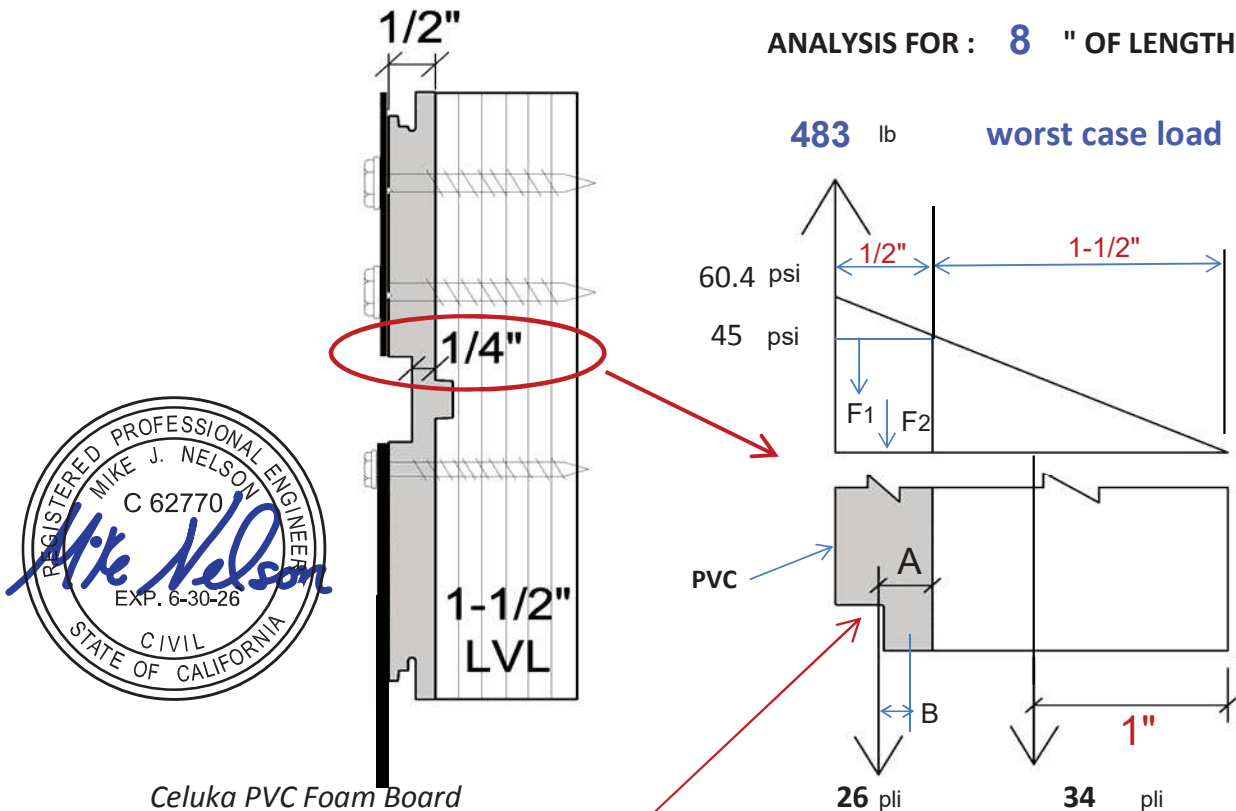

PVC SECTION MODULUS =	0.011	in ³ / in	F ₁ =	4	pli
DIRECT PVC TENSION STRESS =	106	psi	F ₂ =	23	pli
ALLOW. PVC TENSILE STRESS =	2,320	psi	A =	0.262	in.
PVC BENDING MOMENT =	4	lb-in / in	B =	0.137	in.
PVC BENDING STRESS =	338	lb-in	LVL SECTION MODULUS =	0.26	in ³ / in
ALLOW. PVC BENDING STRESS =	2,030	psi	DIRECT LVL STRESS =	27	psi
<u>TENSION</u> + <u>BENDING</u> =	0.21		LVL BENDING MOMENT =	8	lb-in / in
ALLOW TENS.	ALLOW BEND.		LVL BENDING STRESS =	33	psi
			DIRECT + BEND. STRESS =	60	psi < 97 psi CAPACITY
					OK

* 291 psi / 3 F.O.S. = 97 psi (For Radiata Pine LVL, BUT Doug. Fir LVL is being used, which is stronger than Radiata Pine)
 Based on testing by the University of Canterbury

IF PVC RESISTS ALL LOAD BY ITSELF FOR 11 " LONG PIECE

DIRECT PVC TENSION STRESS =	176	psi
ALLOW. PVC TENSILE STRESS =	2,149	psi
PVC BENDING MOMENT =	181	lb-in
PVC BENDING STRESS =	1,538	psi
ALLOW. PVC BENDING STRESS =	3,884	psi
<u>TENSION</u> + <u>BENDING</u> =	0.48	
ALLOW TENS.	ALLOW BEND.	

ALSO, TRIPLE TESTED
 w/ AN AVE. FAILURE
 LOAD = 3,800 lb

WALL ANALYSIS BELOW HINGE BEAM

DEAD LOAD REACTION AT ENDS OF ROOF HINGE BEAMS = 689 lb
ROOF DL OVER 6.54' EFFECTIVE WIDTH = 117 plf
SNOW LOAD REACTION AT BEAM = 1953 lb
SNOW REACTION OVER 6.54' EFFECTIVE WIDTH = 355 plf
.75 SL + DL OVER 6.54' EFFECTIVE WIDTH = 383 plf

ALLOW. AXIAL LOAD IN SEISMIC CATEGORY E

< 1299 plf

- AXIAL LOAD CHECK (DL + SL) = 472 plf < 2200 plf ALLOWABLE OK
- AXIAL LOAD CHECK (DL + .75 SL + .75 WL) = 231 plf > 2200 plf ALLOWABLE OK
- MWFRS WALL PRESSURE = 10.83 psf < 37 psf ALLOWABLE OK
- (DL + WL) INTERACTION RATIO = 0.35 < 1 OK
- (DL + .75 SL + .75 WL) INTERACTION RATIO = 0.32 < 1 OK

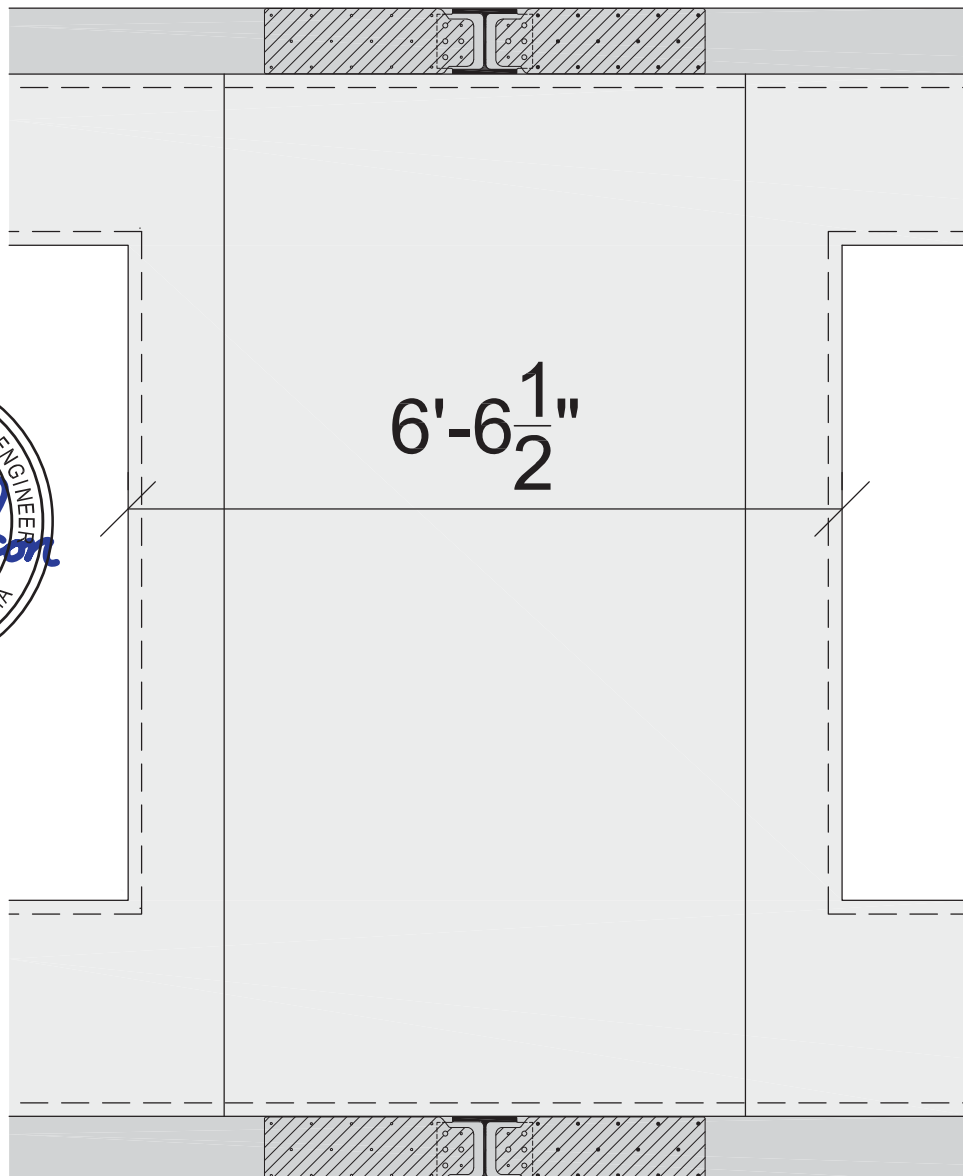

WALLS: COMBINED AXIAL & BENDING (AREAS NOT BELOW BEAM)

LOAD CASE 1 : DL + .75 SL + .75 WL	RLL = 20 psf	WIND = 20.6 (C&C CORNERS)
LOAD CASE 2 : DL + WL	DL = 6 psf	= 17.5 (C&C)
LOAD CASE 3 : WIND ONLY (C & C)	SL = 28 psf	= 10.8 (MWFRS)

18" WALL SEGMENT NEXT TO WINDOW

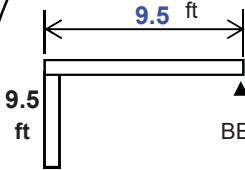
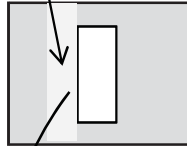

IE SIP = 44,880,000 lb-in² = 96% of total
 IE LVL = 1,968,750 lb-in²
 IE tot = 46,848,750 lb-in²

Portion of load absorbed by sip. Remainder absorbed by internal LVL

LOAD CASE 1

$$\text{AXIAL LOAD} = \left(\frac{DL}{2} + \frac{.75 SL}{1.5} \right) \left(\frac{9.5}{2} \right) \left(\frac{3}{1.5} \right) = \frac{257 \text{ plf}}{2200 \text{ plf allow.}} = 0.12 < 1 \quad \text{OK}$$

$$.75 \text{ WIND LOAD} = 8.1 \left(\frac{3}{1.5} \right) = \frac{16 \text{ psf}}{37 \text{ psf allow.}} = 0.44 < 1 \quad \text{OK}$$

$$\underline{0.56} < 1 \quad \text{OK}$$

LOAD CASE 2

$$\text{AXIAL LOAD} = \frac{DL}{2} \left(\frac{9.5}{2} \right) \left(\frac{3}{1.5} \right) = \frac{57 \text{ plf}}{2200 \text{ plf allow.}} = 0.03 < 1 \quad \text{OK}$$

$$\text{WIND LOAD} = 10.8 \left(\frac{3}{1.5} \right) = \frac{22 \text{ psf}}{37 \text{ psf allow.}} = 0.59 < 1 \quad \text{OK}$$

$$\underline{0.61} < 1 \quad \text{OK}$$

LOAD CASE 3

$$\text{AVE. C \& C WIND LOAD} = \left(\frac{0.96}{1} \right) 19.1 \left(\frac{3}{1.5} \right) = \frac{36.5 \text{ psf}}{37 \text{ psf allow.}} = 0.99 < 1 \quad \text{OK}$$

AT THE 3' TRANSITION PT NEXT TO 3' WIDE WINDOW

LVL BENDING MOM. = 27 lb-ft < 317 lb-ft CAP. **OK**

TRIB. WIDTH EFFECT. BEND. WIDTH

BET. DOOR & WINDOW

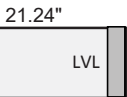
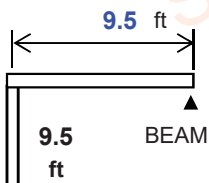
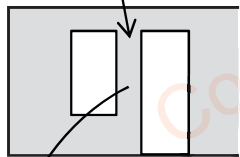

IE SIP = 52,958,000 lb-in² = 54% of total
 IE LVL = 44,494,000 lb-in² = 46% of total
 IE tot = 97,452,600 lb-in²

LOAD CASE 1

$$\text{AXIAL LOAD} = \left(\frac{DL}{2} + \frac{.75 SL}{1.8} \right) \left(\frac{9.5}{2} \right) \left(\frac{4.8}{1.8} \right) = \frac{342 \text{ plf}}{2200 \text{ plf allow.}} = 0.16 < 1 \quad \text{OK}$$

$$.75 \text{ WIND LOAD} = 8.1 \left(\frac{5}{1.8} \right) = \frac{22 \text{ psf}}{37 \text{ psf allow.}} = 0.59 < 1 \quad \text{OK}$$

$$\underline{0.74} < 1 \quad \text{OK}$$

LOAD CASE 2

$$\text{AXIAL LOAD} = \frac{DL}{2} \left(\frac{9.5}{2} \right) \left(\frac{4.8}{1.8} \right) = \frac{76 \text{ plf}}{2200 \text{ plf allow.}} = 0.03 < 1 \quad \text{OK}$$

$$\text{WIND LOAD} = 10.8 \left(\frac{4.8}{1.8} \right) = \frac{29 \text{ psf}}{37 \text{ psf allow.}} = 0.78 < 1 \quad \text{OK}$$

$$\underline{0.82} < 1 \quad \text{OK}$$

LOAD CASE 3

$$\text{C \& C WIND LOAD} = \left(\frac{0.54}{1} \right) 17.5 \left(\frac{4.8}{1.8} \right) = \frac{25 \text{ psf}}{37 \text{ psf allow.}} = 0.68 < 1 \quad \text{O.K.}$$

TRIB. WIDTH EFFECT. BEND. WIDTH



LVL STRENGTH CALC
 Fb = 2900 psi
 S = 7.91 in³
 MOM = 1,912 lb-ft

LVL Moment = 437 lb-ft < 1,912 lb-ft **OK**

ALLOWABLE AXIAL LOAD ANALYSIS IN SEISMIC CATEGORY D & E

ALLOW. AXIAL LOAD IN CAT. A, B, C = **2,200** lb

MAX. ACTUAL SHEAR AT
HIGH END OF CAT. C = **15** plf

ALLOW. SHEAR IN CAT. D, E = **127** plf

DIFF. BET. HIGHEST POSSIBLE SHEAR = **112** plf
IN CAT. C AND ALLOW. SHEAR IN CAT. D

DIFFERENCE IN AXIAL CAPACITY = **1,958** lb

ACTUAL SHEAR = **67** plf



ADJUSTED ALLOWABLE AXIAL LOAD

$$= 242 \text{ lb} + \frac{(127 \text{ plf} - \text{ACTUAL SHEAR}) (1,958 \text{ lb})}{112 \text{ plf}} = \boxed{1299 \text{ plf}}$$

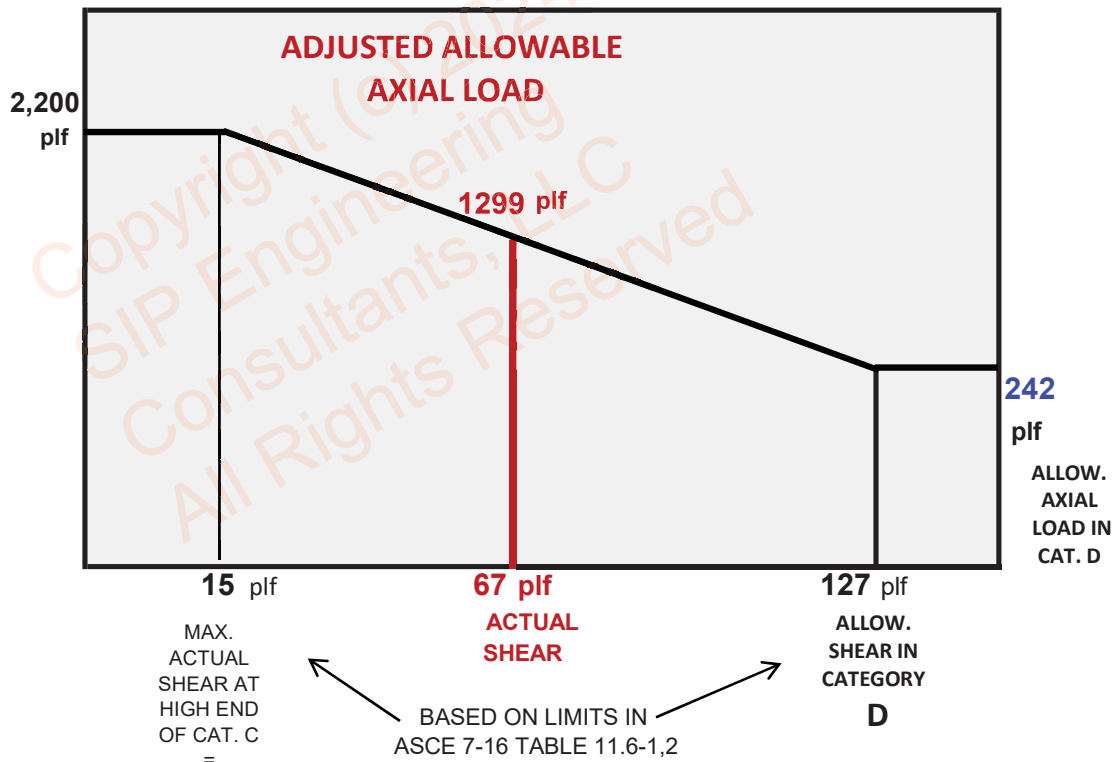

WALLS: COMBINED AXIAL & BENDING (IN SEIS. CAT. D & E)

LOAD CASE 1 : DL + .75 SL + .75 WL

RLL = 20 psf

DL = 6 psf

SL = 28 psf

LOAD CASE 1

$$\text{AXIAL LOAD} = \left(\overset{\text{DL}}{6} + \overset{.75 \text{ SL}}{21} \right) \left(\overset{\text{TRIB.}}{9.5} \right) \left(\overset{\text{MULT.}}{\frac{3}{1.5}} \right) = \frac{257 \text{ plf}}{1299 \text{ plf allow.}} = 0.20 < 1 \quad \text{O.K.}$$

WALL CORNER NEXT TO WINDOW

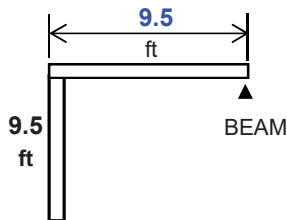
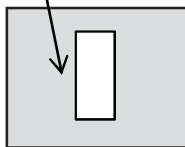

BET. DOOR & WINDOW

LOAD CASE 1

$$\text{AXIAL LOAD} = \left(\overset{\text{DL}}{6} + \overset{.75 \text{ SL}}{21} \right) \left(\overset{\text{TRIB.}}{9.5} \right) \left(\overset{\text{MULT.}}{\frac{4.8}{1.8}} \right) = \frac{342 \text{ plf}}{1299 \text{ plf allow.}} = 0.26 < 1 \quad \text{O.K.}$$

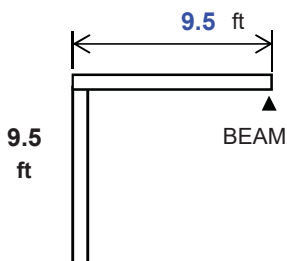
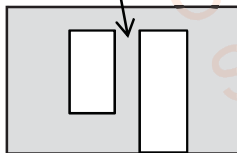

Copyright (c) 2024
SIP Engineering
Consultants,
All Rights Reserved

ROOF SCREW & ROOF EDGE ANALYSIS



ROOF GRAVITY REACTION:

128

lb = **1.52** psi < 6 psi ALLOW

COMPONENT WIND LOAD AT WALL CORNERS:

20.6

psf

COMPONENT WIND LOAD - MIDDLE WALL:

17.5

psf

MWFRS WIND LOAD ON WALL:

10.8

psf

WALL HEIGHT:

9.5

ft

C & C REACTION AT TOP OF WALL AT CORNERS:

98

plf

C & C REACTION AT TOP OF WALL - MIDDLE:

83

plf

MWFRS REACTION AT TOP OF WALL :

51

plf

MWFRS DIAPHRAGM REACTION AT TOP OF WALL :

51

plf

ALLOW. SIP SCREW SHEAR CAP. THRU 1/8" PVC :

102

lb

ALLOW. SIP SCREW SHEAR CAP. IN LVL :

431

lb

% WALL REACTION ABSORBED BY LOWER PVC PIECE :

40%

% WALL REACTION ABSORBED BY SCREWS :

60%

EPS SHEAR STRESS
10" TRUFAST SIPTP-1000

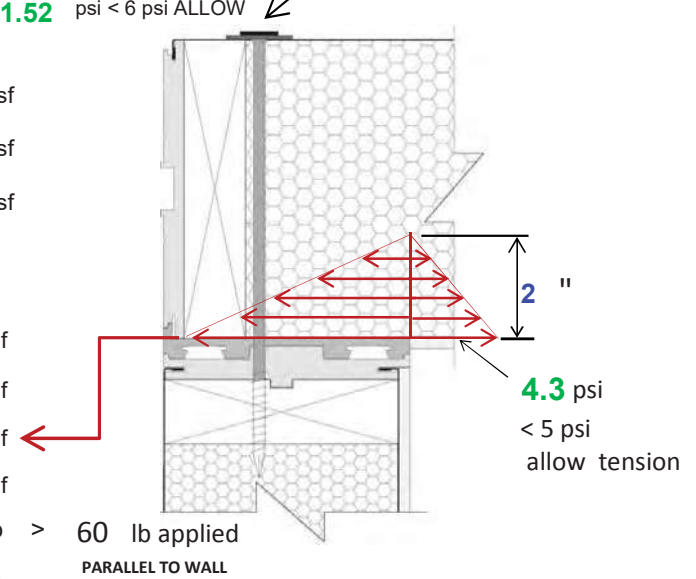

EPS SHEAR/TEN. INTERACTION RATIO = **0.84** < 1 **OK**
USING .75 WL + .75 SL

NET UPLIFT REACTION AT FRONT & BACK WALLS:

130

plf

C & C

NET UPLIFT REACTION AT LEFT & SIDE WALLS:

65

plf

C & C

SCREW SPACING = 14.3 " oc

NET UPLIFT REACTION AT FRONT & BACK WALLS:

186

plf

MWFRS

NET UPLIFT REACTION HINGE BEAM:

1841

lb

C & C

>>>> **6** SCREWS REQ'D OVER

NET UPLIFT REACTION HINGE BEAM:

625

lb

MWFRS

7.0 ft

=

104

plf

MWFRS DISTRIBUTED OVER

SIP SCREW PULLOUT CAPACITY =

336

lb

= 140 lb/in (1.5")(Cd=1.6) 140 FROM DR. J DATA

MWFRS SHEAR / UPLIFT INTERACTION RATIO : **0.74**

C & C values do not apply to analysis involving concurrent loads from 2 orthogonal surfaces, therefore only MWFRS values are used in the interaction equation

	C & C SHEAR RATIO	C & C PULL-OUT RATIO	MWFRS SHEAR RATIO	MWFRS PULL-OUT RATIO
FRONT & BACK WALL CORNER SPACING : 14.3 " oc	0.68	0.46	0.09	0.66
FRONT & BACK WALL MIDDLE SPACING : 14.3 " oc	0.58	0.46	0.09	0.66

LEFT AND RIGHT WALLS DON'T CONTROL

Steel Bolt Group Analysis

J:\Users\Mike\DOCUME~1\WORK\IPR5D2D~1\BOXABL\BOXABL~1\BOXABL PL and HINGE BEAM END PL.ec6 .
 Software copyright ENERCALC, INC. 1983-2019, Build:12.19.12.31 .

Lic. # : KW-06009474

SIP Engineering Consultants

DESCRIPTION: HINGE BEAM END PLATE - MAX. BOLT SHEAR = 1.1545 TIME THE BEAM UPLIFT LOAD. BEAM UPLIFT LOAD = TWICE

Code References

Calculations per, IBC 2018, CBC 2019, ASCE 7-16
 Load Combination Set : IBC 2018

Centroid & Eccentricity

Bolt Group Centroid...
 X Distance 1.313 in
 Y Distance 0.000 in
 Load Eccentricity from C.B.G
 Y Distance 0.000 in
 X Distance 10.438 in
 Total Moment 0.00k-in

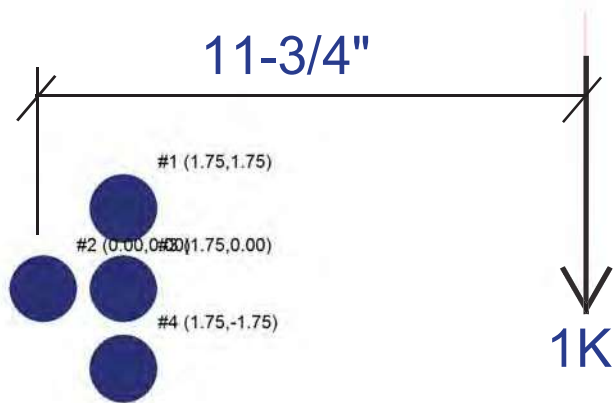
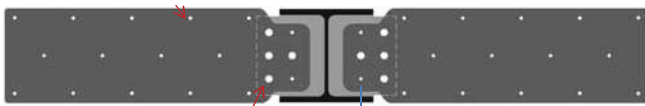

Bolt Locations

Bolt #1	X Location = 1.75 in	Y Location = 1.75 in
Bolt #2	X Location = 0.00 in	Y Location = 0.00 in
Bolt #3	X Location = 1.75 in	Y Location = 0.00 in
Bolt #4	X Location = 1.75 in	Y Location = -1.75 in

Applied Loads

	Dead Load	L : Live Load	Lr : Roof Live	S : Snow	W : Wind	E : Seismic	H : Earth
Load Magnitude	1.000			0.000	0.000	0.000	0.000 k
Application Angle	270.00	0.00	0.00	0.00	0.00	0.00	0.00 deg CCW
Horiz Dist from Datum	11.75 in						
Vert Dist from Datum	0.00 in						

Maximum Bolt Shear Forces

Bolt # Load Combination	Bolt Dist. From C.B.G		Direct Shear Force		Moment	Torsional Shear Force		Final Shear
	X	Y	X	Y		X	Y	
Bo +D+H	0.438 in	1.750 in	0.000k	-0.250 k	-0.87 k-ft	2.169 k	-0.542k	2.309k
Bo +D+H	-1.313 in	0.000 in	0.000k	-0.250 k	-0.87 k-ft	k	1.627k	1.377k
Bo +D+H	0.438 in	0.000 in	0.000k	-0.250 k	-0.87 k-ft	k	-0.542k	0.792k
Bo +D+H	0.438 in	-1.750 in	0.000k	-0.250 k	-0.87 k-ft	-2.169 k	-0.542k	2.309k

This factor incorporated into spreadsheet analysis on next page

2.309 times greater than applied load
 or
 1.1524 time greater than total uplift load at end of beam



HINGE BEAM END PLATE BOLT SHEAR ANALYSIS

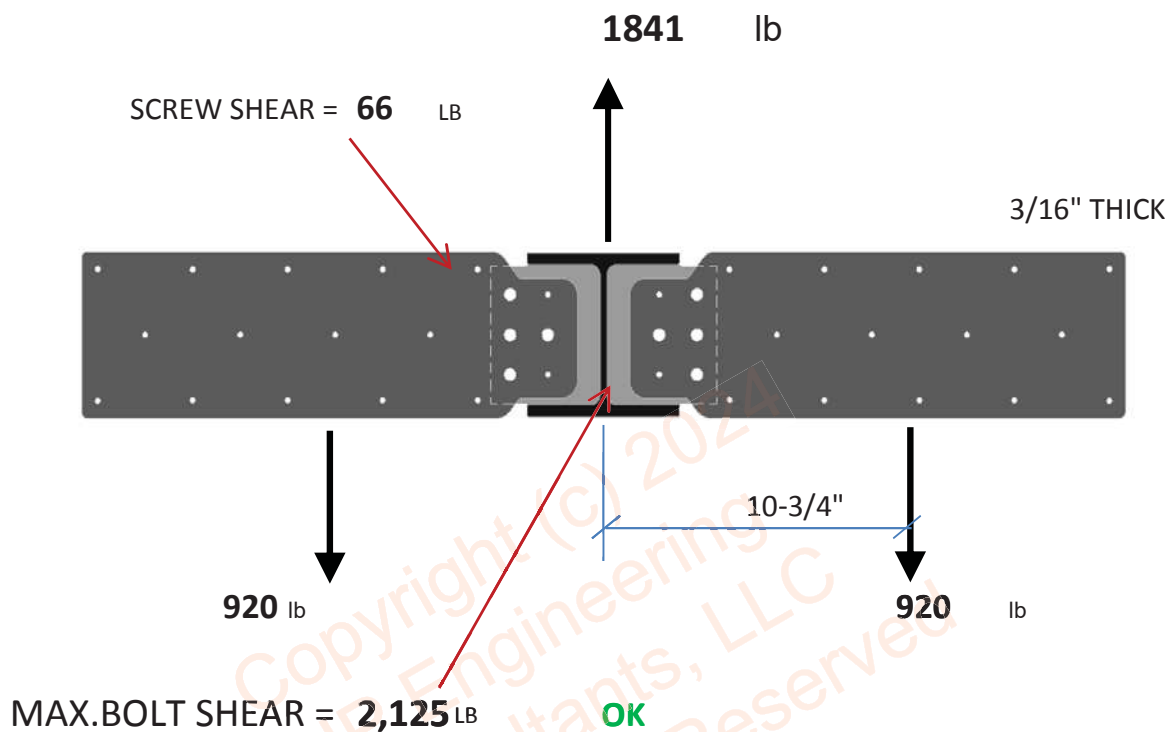

SHEAR CAP. OF 1/2" DIA.

SAE-J429 GR.8 BOLT = **14,000** LB

BOLT BEARING STRESS = **23** KSI **OK**

ALLOW. BEARING STRESS = **70** KSI



ROOF DIAPHRAGM ANALYSIS

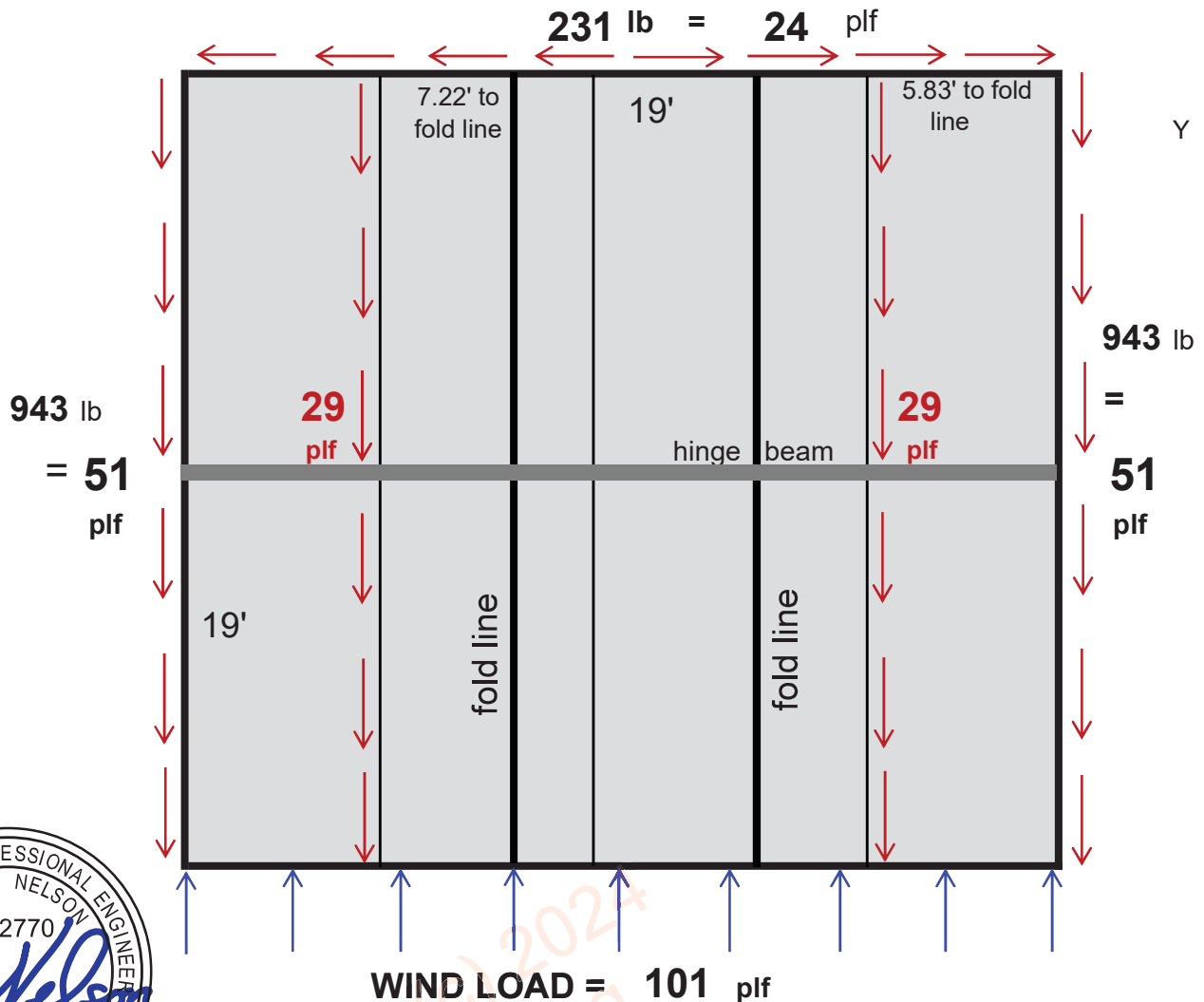

SHEAR ACROSS RIGHT FOLD LINE = 353 lb

CHORD FORCE ACROSS LEFT FOLD LINE = 219 lb

CHORD FORCE ACROSS RIGHT FOLD LINE = 199 lb (RESISTED BY FOLD-LINE HINGE)

The roof and floor diaphragm are constructed similar to the walls, but are thicker. Therefore, it's reasonable to assume the roof and floor diaphragms would have an in-plane shear capacity equal to, or greater, than the wall shear capacity of 349 plf.

As can be seen from the above analysis, the actual shear at the roof/floor diaphragm joint is FAR below 349 plf - clearly too small to worry about.

LOAD CAPACITIES OF STEEL HINGE BEAMS AT ROOF AND FLOOR

3.4 Test Results

Results from testing are provided in the table below.

Beam Depth / Span (in. / in.)	Specimen Description	Specimen Number	Ultimate Load (lbs)	Failure Mode
7 / 223	Floor	147899	12,418	Pin sheared at the tip with bending of the shank
		147900	12,339	Pin sheared at the tip with bending of the shank, and a broken tab
		147901	12,755	Pin sheared at the tip with bending of the shank
	Roof	147903	15,660	Pin sheared at the tip with bending of the shank. (Left side)
		147904	17,515	Pin sheared at the tip with bending of the shank. (Left side)
		147905	16,451	Pin sheared at the tip with bending of the shank. (Left side)

3.5 Summary and Conclusions

Specimen Description	Average Ultimate Load (lbs)	Load at each load Cell ¹ (lbs)
Floor I Beam	12,504	1,563
Roof I Beam	16,542	2,067

¹Load at each loading point was determined by taking the average ultimate load and dividing by the 8 evenly spaced load points

**Equivalent roof uniform loading = 114 psf
(F.O.S. = 3.17 for max. allowed 31 psf snow load)**

**Equivalent floor uniform loading = 87 psf
(F.O.S = 1.93 for total load)**

STEEL MATERIAL PROPERTIES:

HINGE BEAM: ASTM A36 (MIN. Fy = 36 ksi, MIN. Ft_u = 58 ksi)

HINGE : ASTM A572 GR. 50 (MIN. Fy = 50 ksi, MIN. Ft_u = 65 ksi)

HINGE BEAM PINS: H900 HARDENED S17400 S.S.

(MIN. Fy = 170 ksi, MIN. Ft_u = 190 ksi)



Table 2: Axial Load Capacity^{1,2}

Panel Configuration	Allowable Load (plf)
113.875-inch Wall Height	2200

For SI: 1 inch=25.4 mm, 1 plf = 14.59 N/m.

¹Tabulated axial load is the maximum uniform load (pounds per linear foot) applied concentrically to the full thickness of the SIP, including facings, to the top. Eccentric axial loading to one face of the SIP is outside the scope of this report.

²For combined loading, the requirements of Section 4.1 must be applied.

Table 3: Seismic Design Categories A, B, and C Shearwall Racking Load Capacity¹

Panel Configuration	Allowable Load (plf)
113.875-inch Wall Height	349

For SI: 1 inch=25.4 mm, 1 plf = 14.59 N/m.

¹Shearwall capacity limited to walls with a 1:1 (h:w) aspect ratio.

²This shearwall design is limited to use in Seismic Design Categories A, B, and C.

Table 4: Seismic Design Categories A through F Shearwall Racking Load Capacity¹

Panel Configuration	Allowable Load (plf)
113.875-inch Wall Height	127

For SI: 1 inch=25.4 mm, 1 plf = 14.59 N/m.

¹Shearwall capacity limited to walls with a 1:1 (h:w) aspect ratio.

²Axial capacity of shearwalls used in Seismic Design Categories D, E, and F is limited to 11% of the value in Table 2.

³The deflection at allowable shear load is 0.25 inches (6 mm).

Taken from ICC-ESR 4275

Table 1: Transverse Load Capacity (psf)

Panel Configuration	L/180	L/240	L/360
Floor and Roof Panel, Positive Wind Load^{1,3} (113.875-inch long)	31.3	31.3	31.3
Floor and Roof Panel, Negative Wind Load^{2,3} (113.875-inch long)	86.7	86.7	63.5
Wall Panel, Positive Wind Load^{1,4} (113.875-inch long)	38.3	38.3	38.3
Wall Panel, Negative Wind Load^{2,4} (113.875-inch long)	36.6	36.6	36.6

For SI: 1 inch=25.4 mm, 1 psf= 47.88 Pa.

¹Positive wind load direction indicates force applied to the metal facing of the panel (outside surface) towards the MgO facing of the panel (inside surface).

²Negative wind load direction indicates force applied to the MgO facing of the panel (inside surface) towards the metal facing of the panel (outside surface).

³Roof and floor panels are supported with 3 inches of bearing on one end and 6 inches bearing on the other end.

⁴Wall panel allowable loads are based on panels supported through the end caps.



**SIP Engineering
Consultants, LLC**

14845 SW Murray Scholls Dr.
Suite 110 PMB 306
Beaverton, OR 97007
Phone: 503-564-4178

5-20-25

STRUCTURAL CALCULATIONS

BOXABL

ACCESSORY DWELLING UNIT

MODEL BXB-0000**12**

CALIFORNIA DEPT. OF HOUSING AND COMMUNITY DEVELOPMENT

FACTORY-BUILT MODULAR HOUSING PERMIT



5-20-25

**Copyright © 2004
SIP Engineering Consultants, LLC
All Rights Reserved**

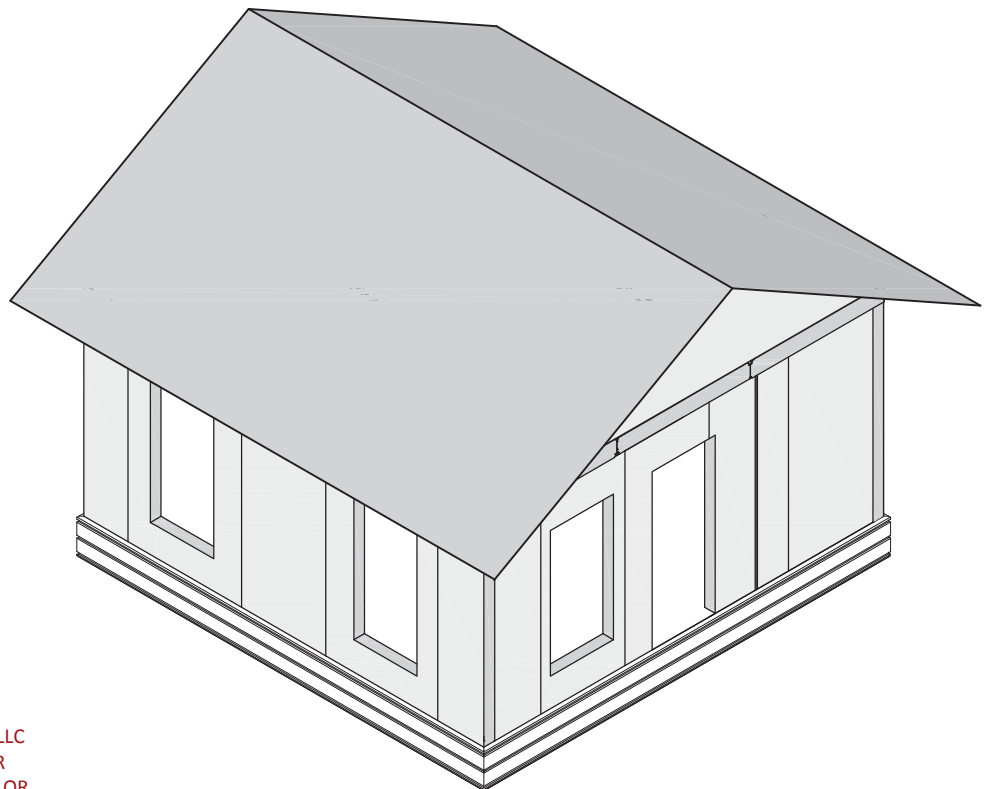

AS INSTRUMENTS OF SERVICE, THESE CALCULATIONS SHALL REMAIN THE PROPERTY OF SIP ENGINEERING CONSULTANTS, LLC WHO SHALL RETAIN ALL COMMON LAW, STATUTORY & OTHER RESERVED RIGHTS, INCLUDING COPYRIGHTS. REPRODUCTION OR DISTRIBUTION IS PROHIBITED WITHOUT THE EXPRESSED, WRITTEN PERMISSION OF SIP ENGINEERING CONSULTANTS, LLC.

DESIGN CRITERIA :

LOCATION :

CA

CODE: **2022 CBC**

SOLAR PANELS ? **Y**

ROOF TRUSSES : **Y**

PMRV ? **N**

GABLE, MONO, or HIP ? **G**

PITCH = **6** :12

TRUSS SPACING : **24** in oc

EAVE OVERHANG = **1.5** ft

UNIFORM LOADS :

GROUND SNOW LOAD : **20** psf (SEIS. CAT. A,B,C)
20 psf (SEIS. CAT. D,E)

WALL HEIGHT = 9.5 ft

ROOF LIVE LOAD : **20** psf

EXPOSURE FACT., Ce = 1

SIP ROOF DEAD LOAD : **5** psf

ASCE 7-16 7.3 (7.3-1)

FLOOR LIVE LOAD : **40** psf

ROOF SL = .7 Pg Ce = **14** psf (SEIS. CAT. A,B,C)

FLOOR DEAD LOAD : **6** psf

STUCCO, HARDI PANEL (PAN) = 14 psf (SEIS. CAT. D,

TOTAL WALL DEAD LOAD : **11** psf

PLANK (PLK), NONE ? S **CARPORT ? N**

TRUSS ROOF DEAD LOAD : **26.2** psf

SIP WALL DEAD LOAD : **5** psf

roof (psf) wall psf psf

MASS OF ROOF + UPPER HALF OF EAVE WALLS = 38.0 + 6 = 43.6
 (DIVIDED OVER ROOF AREA)

FLOOR STEEL WT = 1036 lb

SEISMIC MASS OF END WALL = 1994 lb

ROOF STEEL WT = 561 lb

SEISMIC MASS OF FLOOR = 3202 lb

SHIPPING WT = 13,000 lb

SIP SHELL WEIGHT = 9,098 lb

INTERIOR FIXTURE MASS = 3,902 lb (for F2 calc)

LATERAL LOADS :

TOTAL MASS = 28,214 lb

ULT. NOM.

WIND SPEED : **115** 89 mph Exposure **C** → qh = 14.7 psf
140 109 mph Exposure **B** → qh = 14.7 psf

SEISMIC : I = 1

S1 = 0.97

SD1 = 1.10

Default Site Class = D

**ASPHALT (A), CONCRETE (C)
 CLAY (CL), METAL (M) ROOF ?**

A, C, CL or M : C

D,E = 0.73

Sms = 1.37 = FaSs

A,B,C = 0.93

Fv = 1.7

Sds = (2/3) SMS = 0.91

Fa = 1.2

Ss = 1.14

R = 6.5

Seis. Design Cat. = E

**Seis. Force Resist. = Shear Panels of
 System of Casita steel sheets & mgo**

Analysis Procedure = Equiv. Lateral Force



SEISMIC FORCE CALCULATION

STORIES **1**

$$C_s = \frac{S_{DS}}{(R/I)} = \frac{0.91}{6.5} = 0.141 \quad (12.8-2)$$



PERIOD

$$T = C_t (h_n)^X$$

$$T = (.02)(10.5')^{3/4} = 0.12 < 1.5 T_s = 1.81$$

$T_s = 1.20$

GROUND MOTION HAZARD ANALYSIS NOT REQUIRED
ASCE 7-16 11.4.8 Exception 2

SEISMIC FORCE = $C_s W p = 6.1$ psf
 = **4.4** psf (Allow. Stress.)

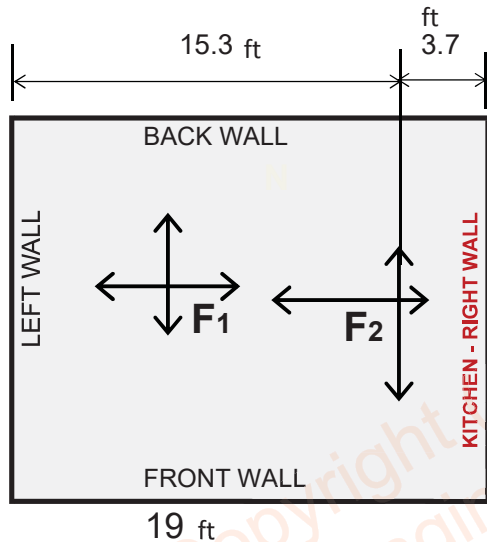

BASE SHEAR = 2,775 lb (ASD)

F2 includes interior fixture mass

ROOF DIAPHRAGM SHEAR = 67 plf < 350 lb allow.

OK

$$F_1 = 4.4 \text{ plf } (19) = 83 \text{ plf (SEISMIC, BUT USE ADJUSTED VALUE BELOW)}$$

$$= 134 \text{ plf WIND PAR. TO GABLE TRUSS DIR.}$$

$$= 16.2 \text{ psf } (5.4) = 87 \text{ plf WIND AT FLOOR LEVEL}$$

$$= 16.2 \text{ psf } (7.7) = 125 \text{ plf WIND PERP. TO GABLE TRUSS DIR.}$$

ROOF F2 = 162 lb

FLOOR F2 = 222 lb

SEISMIC REACTION AT MID-HT OF WALL

$$= 83 (19' / 2) + (.5) 1994 (0.14) .7 \text{ ASD}$$

$$= 887 \text{ lb} \quad C_s$$

LOAD IN LINE WITH WALL

F1 BOT. HALF OF WALL = 98 lb

F1 seis AT ROOF LEVEL ADJUSTED TO INCLUDE SEIS. LOAD OF ENDWALL

= **93** plf

F1seis of GROUND FLOOR + BOT. HALF OF ALL 4 WALLS = 707 lb

LATERAL WIND LOAD CALCULATIONS

PER ASCE 7-16 SECTION 27.3

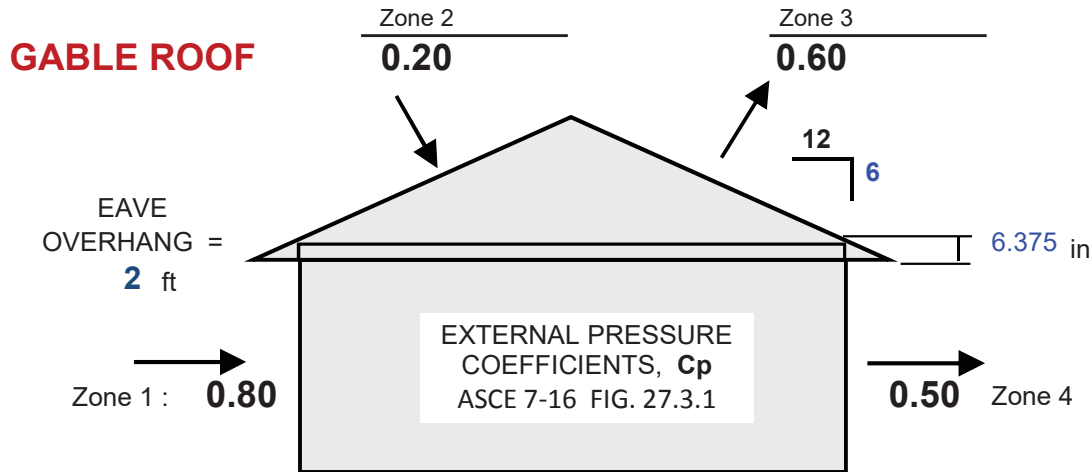

BUILDING WIDTH (parallel to load) = **19** ft L / B = 1.00
 BUILDING LENGTH (perp to load) = **19** ft h / L = 0.65

ULT. WIND SPEED = **115** MPH

EXPOSURE = **C**

ROOF ANGLE = **26.6** DEG.

WALL HT = **9.5** Ft

DIAG. ROOF DIM. = **10.6** Ft
 (ridge to eave)

kh = 0.85
kz = 0.85
kzt = 1.00
ke = 1.00
kd = 0.85

V = 115

I = 1

(ASD) $q_h = (.6) .00256 k_h k_{zt} k_d k_e v^2 I = 14.7$ psf

(ASD) $q_z = (.6) .00256 k_z k_{zt} k_d k_e v^2 I = 14.7$ psf

WIND PRESSURE, $p = q G C_p$ $G = 0.85$



ZONE	1	2	3	4
PRESSURE (psf)	10.0	2.5	7.5	6.2
TOTAL LOAD (lb)	47.3	32.1	96.2	29.6
HORIZ. LOAD (plf)	47.3	14.3	43.0	29.6
TOTAL HORIZ. LOAD =	134	PLF		

	absolute value	absolute value	effective wind area
LEEWARD COMPONENT WALL LOAD = $q_h (G C_p + .18) =$	17.9 psf	1.04	45 ft
LEEWARD COMPONENT WALL LOAD AT CORNERS =	21.0 psf within 3'	1.25	28 ft
WINDWARD COMPONENT WALL LOAD AT CORNERS =	16.4 psf within 3'	0.94	28 ft

LATERAL WIND LOAD CALCULATIONS

PER ASCE 7-16 SECTION 27.3

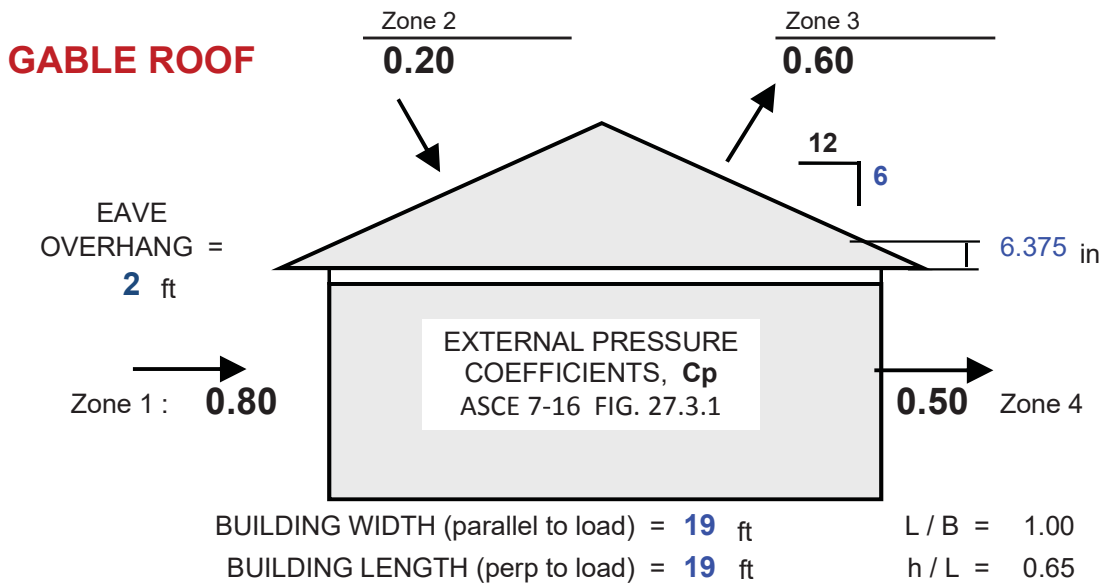

ULT. WIND SPEED = **135** MPH

EXPOSURE = **B**

ROOF ANGLE = **26.6** DEG.

WALL HT = **9.5** Ft

DIAG. ROOF DIM. = **10.6** Ft
(ridge to eave)

$k_h = 0.57$

$k_z = 0.57$

$k_{zt} = 1.00$

$k_e = 1.00$

$k_d = 0.85$

$V = 135$

$I = 1$



(ASD) $q_h = (.6) .00256 k_h k_{zt} k_d k_e V^2 I = 13.6$ psf

(ASD) $q_z = (.6) .00256 k_z k_{zt} k_d k_e V^2 I = 13.7$ psf

115 mph, Exp. C
controls
see previous page

WIND PRESSURE, $p = q G C_p$ $G = 0.85$

ZONE	1	2	3	4
PRESSURE (psf)	9.3	2.3	6.9	5.8
TOTAL LOAD (lb)	44.2	29.6	88.9	27.4
HORIZ. LOAD (plf)	44.2	13.3	39.8	27.4

TOTAL HORIZ. LOAD = 125 PLF

	absolute value	Gcp	effective wind area
LEEWARD COMPONENT WALL LOAD = $q_h (G C_p + .18) =$	16.5 psf	1.04	45 ft
LEEWARD COMPONENT WALL LOAD AT CORNERS =	19.4 psf within 3'	1.25	28 ft
WINDWARD COMPONENT WALL LOAD AT CORNERS =	15.2 psf within 3'	0.94	28 ft

RIGHT WALL

GABLE ROOF TRUSSES & WIND PARALLEL TO SLOPE DIR.

6 :12 SLOPE

FLOOR ANCHORS TO : CONCRETE W/ VERT. PL



SEISMIC SHEAR = $\frac{\text{TRUSS END}}{\text{length}} + 57 = 1075 = 72 \text{ plf} < 127 \text{ plf cap.}$ **O.K.**

At bot. of wall controls. Windows accounted for in wall test.

WIND SHEAR = $\frac{18.0 \text{ twice test wall length}}{18.0} = 1276 = 85 \text{ plf} < 349 \text{ plf cap.}$ **O.K.**

SEIS. CATEGORY : **E**

UPLIFT LOAD PER UPPER PL = 0 lb
 LATERAL LOAD PER UPPER PL = 54 lb
 UPPER ROW OF UPPER PL RESULTANT LOAD = 54 lb < 740 lb

FORCE TRANSFER AROUND OPENING METHOD
 PER WALL W/ OPEN TEST X 2
 TOTAL WIND CAP. = 3474 lb
 TOTAL SEISMIC CAP. = 1264 lb

UPLIFT/LATERAL CAP. OF UPPER #10 ROW ON UPPER PL = 740 lb
 LATERAL CAP. OF LOWER #10 ROWS OF UPPER PL = 422 lb
 UPLIFT CAP. OF LOWER #10 ROWS ON UPPER PL = 1,295 lb
 TOTAL TITEN SCREW UPLIFT CAPACITY OF LOWER PL = 1,317 lb
 TOTAL TITEN SCREW HORIZ. CAPACITY OF LOWER PL = 717 lb
 TOTAL WOOD SCREW UPLIFT & SHEAR CAP. OF LOWER PL = 1491 lb
 TOTAL HORIZ. CAP. OF WALL-TO-FL TOE SCREWS = 1,685 lb
 % OF TOE SCREW LATERAL CAPACITY USED = 50 %

UPPER BOXABL SHEAR PL'S REQ'D = 1.0 USE [8]
 INTERACTION RATIO OF LOWER SCREWS OF UPPER PL = 0.13 0.10
 # LOW SHEAR PL'S REQ'D FOR WOOD SCREW SHEAR = 1.4 USE [5]
 LOW. H.D. PL TOT. RESULT. WOOD SCREW SHEAR = 420 lb INCL. ONE AROUND CORNER
 INTERACTION RATIO OF LOW. PL TITEN SCREWS = 0.59 0.56 CORNER

ABOVE INTERACTION RATIOS INCLUDE SHEAR & UPLIFT FORCES

WIND
 Holddown = $\frac{1276 (9.5)}{17.8 \text{ ft}} + \frac{\text{net uplift} - .6(\text{wall wt})}{\text{plf length}} = -99 + 3 (2.5) (9/2) = -255 \text{ lb}$

UPLIFT DISTRIBUTED OVER 8 " IN LVL RIM
 CROSS-GRAIN TEN. CAP. OF LVL = 770 lb > 0 lb

HOLDDOWN REQ'TS BOTH CORNERS

[0] UPPER PLATES → use [1] [0 lb ea.]
 [0] LOW. PLATES → use [2] [0 lb ea.]
 to satisfy interaction ratio

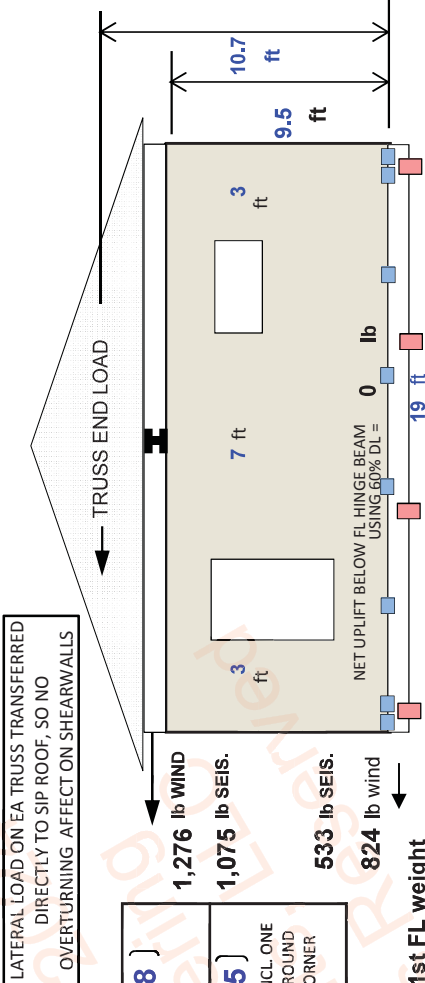

REAR WALL

GABLE ROOF TRUSSES & WIND PARALLEL TO SLOPE DIR.

6 :12 SLOPE

FLOOR ANCHORS TO : CONCRETE w/ VERT. PL

RIGHT SIDE ASPECT RATIO CAPACITY ADJUSTMENT = 0.93
 RIGHT SIDE WIND SHEAR CAP. = 0.93 [349] = 325 plf
 RIGHT SIDE SEIS. SHEAR CAP. = 0.93 [127] = 118 plf

$$F_2/2 = \frac{97}{2} + 93 (19'/2) + 57.4 = 1041 \text{ lb}$$

LEFT SIDE ASPECT RATIO CAPACITY ADJUSTMENT = 0.88
 LEFT SIDE WIND SHEAR CAP. = 0.88 [349] = 306 plf
 LEFT SIDE SEIS. SHEAR CAP. = 0.88 [127] = 111 plf

WIND LOAD = 134 (19'/2) = 1276 lb

% OF TOE SCREW LATERAL CAPACITY USED = 50 %

6'	7.5'
WALL	WALL

UPLIFT LOAD PER UPPER PL = 196 325 lb
LATERAL LOAD PER UPPER PL = 37 101 lb
UPPER ROW OF UPPER PL RESULTANT LOAD = 199 340 lb < 740 lb
TOTAL SHEAR CAP. OF WALL-TO-FL TOE SCREWS = 599 702 lb

# UPPER BOXABL SHEAR PL'S REQ'D = 0.5	1.0
# UPPER BOXABL SHEAR PL'S USED = 6	4
INTERACTION RATIO OF LOW. SCREWS OF UP. PL = 0.24	0.49
# LOW SHEAR PL'S REQ'D FOR WOOD SCREW SHEAR = 0.6	0.8
# LOWER PLATES USED = 4	4
LOW. H.D. PL TOT. RESULT. WOOD SCREW SHEAR = 318	373 lb
INTERACTION RATIO OF LOW. PL TITEN SCREWS = 0.49	0.58

LEFT WALL
 net uplift - 6(wall wt) = $523 (9.5) + \frac{5.5}{\text{plf}} - 100 \left[\frac{6.4}{2} \right] = 587 \text{ lb}$
 this value incl. floor wt (same as ceiling) → = 433 lb → use 2

RIGHT WALL
 Holddown Force = $753 (9.5) + \frac{7.0}{\text{plf}} - 100 \left[\frac{7.5}{2} \right] = 651 \text{ lb}$
 this value incl. floor wt (same as ceiling) → = 465 lb → use 2

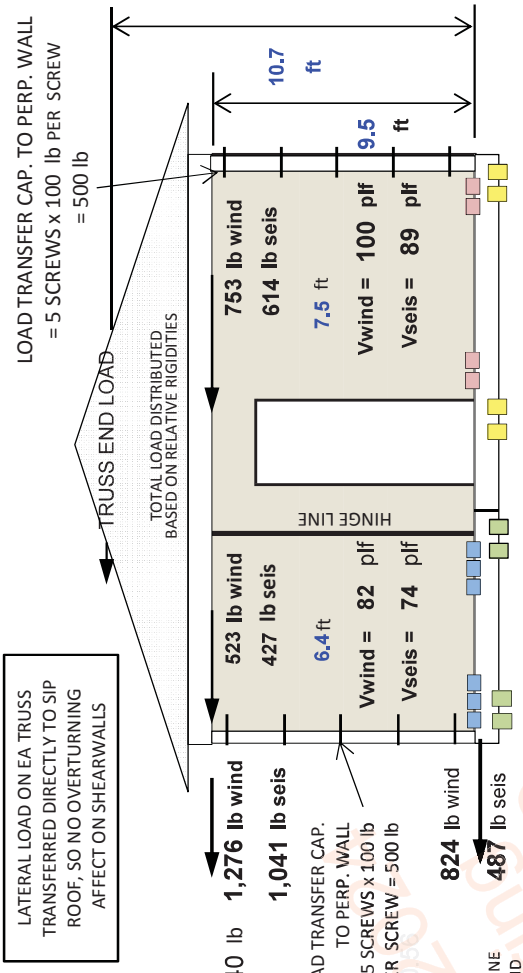

LOAD TRANSFER CAP. TO PERP. WALL = 5 SCREWS x 100 lb PER SCREW = 500 lb
 TOTAL LOAD DISTRIBUTED BASED ON RELATIVE RIGIDITIES
 UPLIFT LOAD DISTRIBUTED OVER 9 " IN LVL RIM
 CROSS-GRAIN TENSION CAP. OF LVL = 870 lb > 325 lb

HOLDDOWN REQUIREMENTS
 1st fl weight = $3 (4.75) (6/2) = 47.25 \text{ psf}$
 psf perp. trb par. trb
 UPPER PL → use 3 (196 lb ea.)
 LOW. PLATES → use 2 (216 lb ea.)

HOLDDOWN REQUIREMENTS
 UPPER PL → use 2 (325 lb ea.)
 LOW. PLATES → use 2 (233 lb ea.)

FRONT WALL

GABLE ROOF TRUSSES & WIND PARALLEL TO SLOPE DIR.

6 :12 SLOPE

FLOOR ANCHORS TO : CONCRETE w/ VERT. PL

$$\frac{F_2/2}{\text{TRUSS END}} + 57 = 93 \quad (19'2) + 57 = 1041 \text{ lb}$$

$$\text{WIND LOAD} = 134 \quad (19'2) = 1276 \text{ lb}$$

RIGHT SIDE ASPECT RATIO CAPACITY ADJUSTMENT = 0.81
RIGHT SIDE WIND SHEAR CAP. = $0.81 [349] = 282 \text{ plf}$
RIGHT SIDE SEIS. SHEAR CAP. = $0.81 [127] = 103 \text{ plf}$
LEFT SIDE ASPECT RATIO CAPACITY ADJUSTMENT = 0.93
LEFT SIDE WIND SHEAR CAP. = $0.93 [349] = 325 \text{ plf}$
LEFT SIDE SEIS. SHEAR CAP. = $0.93 [127] = 118 \text{ plf}$



FORCE TRANSFER AROUND OPENING METHOD

% OF TOE SCREW LATERAL CAPACITY USED = 50 %

LEFT SIDE TESTED WIND LOAD CAPACITY = 1737 lb
 LEFT SIDE CAPACITY ADJUSTED FOR SEIS. = 632 lb

SEE 'SIDE WALLS' CALC FOR FASTENER CAPACITIES

LATERAL LOAD ON EA TRUSS TRANSFERRED DIRECTLY TO SIP ROOF, SO NO OVERTURNING AFFECT ON SHEARWALLS

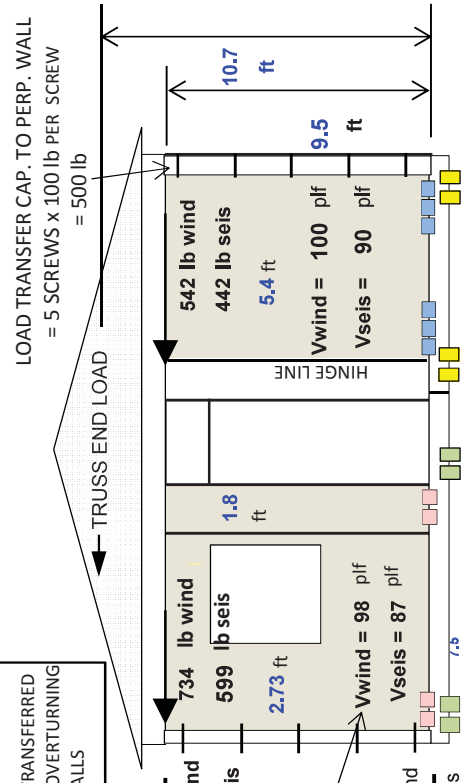

LOAD TRANSFER CAP. TO PERP. WALL = 5 SCREWS x 100 lb PER SCREW = 500 lb

	LEFT WALL	RIGHT WALL
UPLIFT LOAD PER UPPER PL =	359	302 lb
LATERAL LOAD PER UPPER PL =	96	48 lb
UPPER ROW OF UPPER PL RESULTANT LOAD =	372	305 lb < 740 lb
TOTAL SHEAR CAP. OF WALL-TO-FL TOE SCREWS =	702	506 lb
# UPPER BOXABL SHEAR PL'S REQ'D =	0.9	0.7
# UPPER BOXABL SHEAR PL'S USED =	4	6
INTERACTION RATIO OF LOW. SCREWS OF UP. PL =	0.50	0.35
# LOW SHEAR PL'S REQ'D FOR WOOD SCREW SHEAR =	0.8	0.5
# LOWER PLATES USED =	4	4
LOW. H.D. PL TOT. RESULT. WOOD SCREW SHEAR =	367	394 lb
INTERACTION RATIO OF LOW. PL TITEN SCREWS =	0.57	0.51

UPLIFT LOAD DISTRIBUTED OVER 8 " IN LVL RIM
 CROSS-GRAIN TENSION CAP. OF LVL = 770 lb > 359 lb

1st fl weight

HOLDDOWN REQUIREMENTS

LEFT SIDE
 net uplift - .6(wall wt) = $\frac{734 [9.5]}{\text{Len}} + \frac{6.4}{\text{Len}} - 100 \left[\frac{7.5/2}{\text{Len}} \right] = 719 \text{ lb} \rightarrow [1] \text{ UPPER PL} \rightarrow \text{use } 2 [359 \text{ lb ea.}]$
 to satisfy interaction ratio

7.9 FT AT LOWER PL = this value incl. floor wt (same as ceiling) $\rightarrow = 457 \text{ lb} \rightarrow [1] \text{ LOW. PLATES use } 2 [229 \text{ lb ea.}]$

RIGHT SIDE

EXTRA PLATE ON RIGHT SIDE TO ACCOMMODATE CENTRIPETAL FORCE DURING TRANSPORT

Holddown Force = $542 [9.5] + \frac{4.4}{\text{Len}} - 100 \left[\frac{5.4/2}{\text{Len}} \right] = 905 \text{ lb} \rightarrow [2] \text{ UPPER PL} \rightarrow \text{use } 3 [302 \text{ lb ea.}]$
 to satisfy interaction ratio

5.1 FT AT LOWER PL = this value incl. floor wt (same as ceiling) $\rightarrow = 705 \text{ lb} \rightarrow [1] \text{ LOW. PLATES use } 2 [353 \text{ lb ea.}]$
 to satisfy interaction ratio

LEFT WALL

**GABLE ROOF TRUSSES & WIND PARALLEL TO SLOPE DIR.
6 :12 SLOPE**



FLOOR ANCHORS TO : CONCRETE W/ VERT. PL

SEISMIC SHEAR = $\frac{\text{TRUSS END}}{\text{from roof F}_2} + 93 (19/2) + 57 = 1075 = 72 \text{ plf} < 127 \text{ plf cap.}$ **O.K.**

At bot. of wall controls.
Windows accounted for in wall test.

WIND SHEAR = $134 (19/2) = 1276 = 85 < 349 \text{ plf cap.}$ **O.K.**

SEIS. CATEGORY : **E**

UPLIFT/LATERAL CAP. OF UPPER #10 ROW ON UPPER PL = 740 lb	UPLIFT LOAD PER UPPER PL = 0 lb
LATERAL CAP. OF LOWER #10 ROWS OF UPPER PL = 422 lb	LATERAL LOAD PER UPPER PL = 108 lb
UPLIFT CAP. OF LOWER #10 ROWS ON UPPER PL = 1,295 lb	UPPER ROW OF UPPER PL RESULTANT LOAD = 108 lb < 740 lb
TOTAL TITEN SCREW UPLIFT CAPACITY OF LOWER PL = 1,317 lb	FORCE TRANSFER AROUND OPENING METHOD
TOTAL TITEN SCREW HORIZ. CAPACITY OF LOWER PL = 717 lb	PER WALL w/ OPEN TOTAL WIND CAP. = 3474 lb
TOTAL WOOD SCREW UPLIFT & SHEAR CAP. OF LOWER PL = 1491 lb	TEST x 2 TOTAL SEISMIC CAP. = 1264 lb
TOTAL HORIZ. CAP. OF WALL-TO-FL TOE SCREWS = 1,685 lb	
% OF TOE SCREW LATERAL CAPACITY USED = 50 %	

UPPER BOXABL SHEAR PL'S REQ'D = 1.0 USE [4]
INTERACTION RATIO OF LOWER SCREWS OF UPPER PL = 0.26 0.20
LOWER SHEAR PL'S REQ'D FOR WOOD SCREW SHEAR = 1.4 USE [5]
LOW. H.D. PL TOT. RESULT. WOOD SCREW SHEAR = 420 lb INCL ONE AROUND CORNER
INTERACTION RATIO OF LOW. PL TITEN SCREWS = 0.59 0.56 CORNER

ABOVE INTERACTION RATIOS INCLUDE SHEAR & UPLIFT FORCES

WIND Holddown = $1276 \left[\frac{9.5}{17.8 \text{ ft}} \right] + \text{net uplift} - .6(\text{wall wt}) = -99 \left[\frac{19}{2} \right] - 3 \left[\frac{2.5}{9/2} \right] \left[\frac{9}{2} \right]$

Force = 17.8 ft

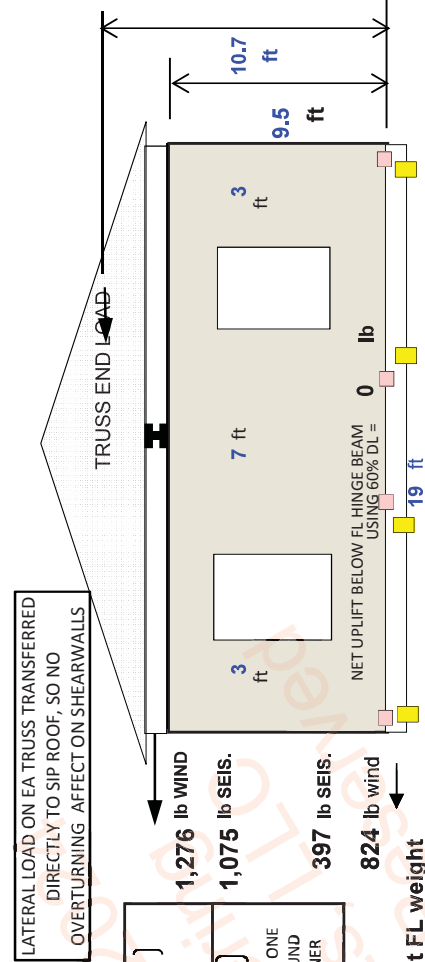

UPLIFT DISTRIBUTED OVER 9 " IN LVL RIM

CROSS-GRAIN TEN. CAP. OF LVL = 870 lb > 0 lb

HOLDDOWN REQ'TS BOTH CORNERS

[0] UPPER PLATES	→ use [1]	[0 lb / pl]
[0] LOW. PLATES	→ use [1]	[0 lb / pl]

to satisfy interaction ratio

RIGHT WALL

GABLE ROOF TRUSSES & WIND PERP. TO SLOPE DIR.

6 :12 SLOPE

FLOOR ANCHORS TO : CONCRETE w/ VERT. PL

SEISMIC SHEAR = $\frac{\text{TRUSS END}}{\text{wall length}} + 57 = 1075 = 67 \text{ plf} < 127 \text{ plf cap.}$ **O.K.**

At bot. of wall controls. Windows accounted for in wall test.

WIND SHEAR = $125 (19'2) = 1188 = 79 \text{ plf} < 349 \text{ plf cap.}$ **O.K.**

SEIS. CATEGORY : **E**

UPLIFT/LATERAL CAP. OF UPPER #10 ROW ON UPPER PL = 740 lb (185 lb x 4)	UPLIFT LOAD PER UPPER PL = 0 lb
LATERAL CAP. OF LOWER #10 ROWS OF UPPER PL = 422 lb	LATERAL LOAD PER UPPER PL = 43 lb
UPLIFT CAP. OF LOWER #10 ROWS ON UPPER PL = 1,295 lb	UPPER ROW OF UPPER PL RESULTANT LOAD = 43 lb < 740 lb

FORCE TRANSFER AROUND OPENING METHOD
WALL TEST: TOTAL WIND CAP. = 3474 lb
WALL TEST: TOTAL SEISMIC CAP. = 1264 lb

TOTAL WOOD SCREW UPLIFT & SHEAR CAP. OF LOWER PL = 1491 lb
 TOTAL HORIZ. CAP. OF WALL-TO-FL TOE SCREWS = 1,685 lb
 % OF TOE SCREW LATERAL CAPACITY USED = 50 %

# UPPER BOXABL SHEAR PL'S REQ'D = 0.8	USE { 8 }
INTERACTION RATIO OF LOWER SCREWS OF UPPER PL = 0.10	
# LOW SHEAR PL'S REQ'D FOR WOOD SCREW SHEAR = 1.3	USE { 5 }
LOW. H.D. PL TOT. RESULT. WOOD SCREW SHEAR = 402 lb	
INTERACTION RATIO OF LOW. PL TITEN SCREWS = 0.56	

ABOVE INTERACTION RATIOS INCLUDE SHEAR & UPLIFT FORCES

WIND
 Holddown = $1188 (9.5) + \frac{\text{net uplift} - .6(\text{wall wt})}{\text{length}} - 3.6 \left[\frac{19}{2} \right] \left[\frac{9}{2} \right]$
 Force = $17.8 - 125 \left[\frac{19}{2} \right] \left[\frac{9}{2} \right] + 72$
 = -539 lbs

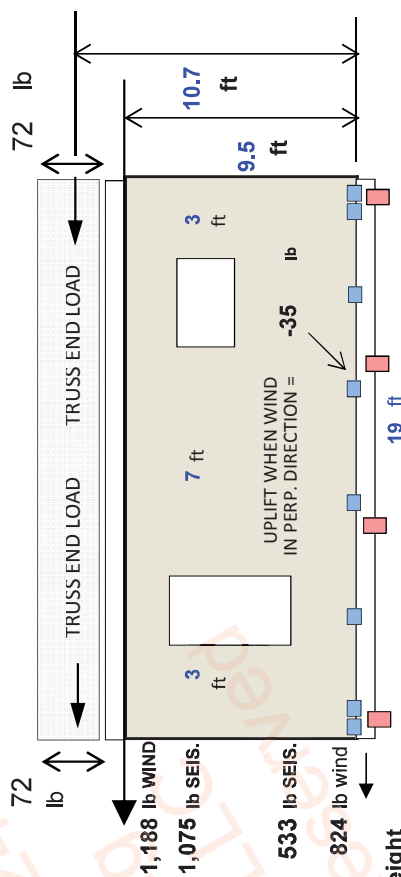

UPLIFT LOAD DISTRIBUTED OVER 9 " IN LVL RIM
 CROSS-GRAIN TENSION CAP. OF LVL = 870 lb > 0 lb
 HOLDDOWN REQ'TS BOTH CORNERS
 [0] UPPER PLATES → use [1] [0 lb / pl]
 [0] LOW. PLATES → use [1] [0 lb / pl]
 to satisfy interaction ratio



REAR WALL

GABLE ROOF TRUSSES & WIND PERP. TO SLOPE DIR.
6 :12 SLOPE

FLOOR ANCHORS TO : CONCRETE w/ VERT. PL

RIGHT SIDE ASPECT RATIO CAPACITY ADJUSTMENT = 0.93
RIGHT SIDE WIND SHEAR CAP. = 0.93 (349) = 324 plf
RIGHT SIDE SEIS. SHEAR CAP. = 0.93 (127) = 118 plf

LEFT SIDE ASPECT RATIO CAPACITY ADJUSTMENT = 0.88
LEFT SIDE WIND SHEAR CAP. = .88(349) = 307 plf
LEFT SIDE SEIS. SHEAR CAP. = 0.88 (127) = 112 plf

SEISMIC LOAD = $\frac{F_2/2}{TRUSS\ END.} + 57 = 93 (19/2) + 57 = 1041\text{ lb}$

WIND LOAD = $125 (19/2) = 1188\text{ lb}$

LOAD TRANSFER CAP. TO PERP. WALL = 5 SCREWS x 100 lb PER SCREW = 500 lb

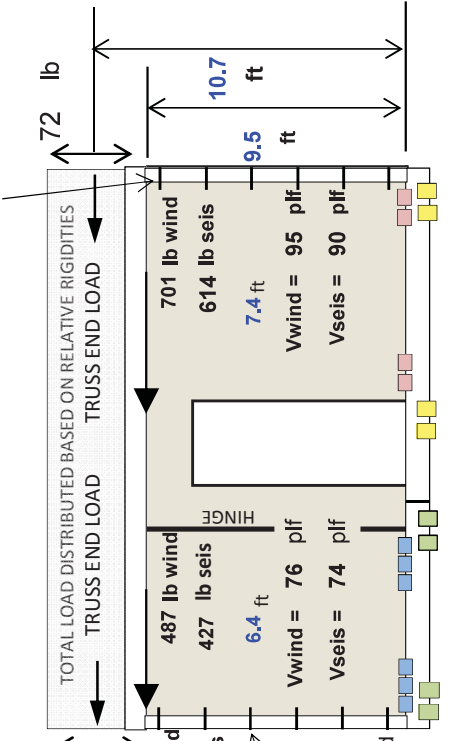

UPPER ROW OF UPPER PL RESULTANT LOAD = 466 lb < 740 lb

TOTAL SHEAR CAP. OF WALL-TO-FL TOE SCREWS = 599 lb

UPPER BOXABL SHEAR PL'S REQ'D = 0.4

UPPER BOXABL SHEAR PL'S USED = 6

INTERACTION RATIO OF LOW. SCREWS OF UP. PL = 0.30

LOW SHEAR PL'S REQ'D FOR WOOD SCREW SHEAR = 0.6

LOW. H.D. PL TOT. RESULT. WOOD SCREW SHEAR = 225

INTERACTION RATIO OF LOW. PL TITEN SCREWS = 0.59



WALL	WALL	WALL	WALL	WALL	WALL
295	457	31	89	466	693
UPLIFT LOAD PER UPPER PL =	457 lb	LATERAL LOAD PER UPPER PL =	31 lb	UPPER ROW OF UPPER PL RESULTANT LOAD =	466 lb
# UPPER BOXABL SHEAR PL'S REQ'D =	0.4	# UPPER BOXABL SHEAR PL'S USED =	6	INTERACTION RATIO OF LOW. SCREWS OF UP. PL =	0.30
# LOWER PLATES USED =	4	# LOW SHEAR PL'S REQ'D FOR WOOD SCREW SHEAR =	0.6	LOW. H.D. PL TOT. RESULT. WOOD SCREW SHEAR =	225
INTERACTION RATIO OF LOW. PL TITEN SCREWS =	0.59				

net uplift - .6(wall wt) = $487 (9.5) + 5.5 - 19 (6.4/2) = 4886\text{ lb}$

1st fl weight + 72 = 886 lb

UPPER PL → use 3 (295 lb / pl)

6.3 FT AT LOWER PL → use 2 (370 lb / pl)

RIGHT WALL

Holddown Force = $701 (9.5) + 7.0 - 19 (7.4/2) = 915\text{ lb}$

UPPER PL → use 2 (457 lb / pl)

8 FT AT LOWER PL → use 2 (355 lb / pl)

to satisfy interaction ratio

FRONT WALL

GABLE ROOF TRUSSES & WIND PERP. TO SLOPE DIR.

6 :12 SLOPE

FLOOR ANCHORS TO : CONCRETE w/ VERT. PL

RIGHT SIDE ASPECT RATIO CAPACITY ADJUSTMENT = 0.81
RIGHT SIDE WIND SHEAR CAP. = 0.81 (349) = 283 plf
RIGHT SIDE SEIS. SHEAR CAP. = 0.81 (127) = 103 plf
LEFT SIDE ASPECT RATIO CAPACITY ADJUSTMENT = 0.93
LEFT SIDE WIND SHEAR CAP. = 0.93 (349) = 326 plf
LEFT SIDE SEIS. SHEAR CAP. = 0.93 (127) = 119 plf

SEISMIC LOAD = $\frac{F_2/2}{TRUSS\ END} + 57$ = 984 lb

WIND LOAD = 125 (19/2) = 1188 lb

SEE "SIDE WALLS" CALC FOR FASTENER CAPACITIES

% OF TOE SCREW LATERAL CAPACITY USED =	50	%
LEFT WALL	RIGHT WALL	
UPLIFT LOAD PER UPPER PL = 524	418	lb
LATERAL LOAD PER UPPER PL = 83	42	lb
UPPER ROW OF UPPER PL RESULTANT LOAD = 531	420	lb < 740 lb
TOTAL SHEAR CAP. OF WALL-TO-FL TOE SCREWS = 702	506	lb



# UPPER BOXABL SHEAR PL'S REQ'D =	0.8	0.6
# UPPER BOXABL SHEAR PL'S USED =	4	6
INTERACTION RATIO OF LOW. SCREWS OF UP. PL =	0.60	0.42
# LOW SHEAR PL'S REQ'D FOR WOOD SCREW SHEAR =	0.7	0.4
# LOWER PLATES USED =	4	4
LOW. H.D. PL TOT. RESULT. WOOD SCREW SHEAR =	457	402
INTERACTION RATIO OF LOW. PL TITEN SCREWS =	0.66	0.51

LEFT SIDE net uplift - .6(wall wt)

Holddown Force = $683 (9.5) + \frac{-19}{Len} \left[\frac{7.5}{2} \right]$ = 1,049 lb

7.9 FT AT LOWER PL

RIGHT SIDE

Holddown Force = $505 (9.5) + \frac{-19}{Len} \left[\frac{5.4}{2} \right]$ = 1,253 lb

6.1 FT AT LOWER PL

FORCE TRANSFER AROUND OPENING METHOD

TOTAL LOAD DISTRIBUTED BASED ON RELATIVE RIGIDITIES TO PERP. WALL = 5 SCREWS x 100 lb PER SCREW = 500 lb

LEFT SIDE TESTED WIND LOAD CAPACITY = 1737 lb

LEFT SIDE CAPACITY ADJUSTED FOR SEIS. = 632 lb

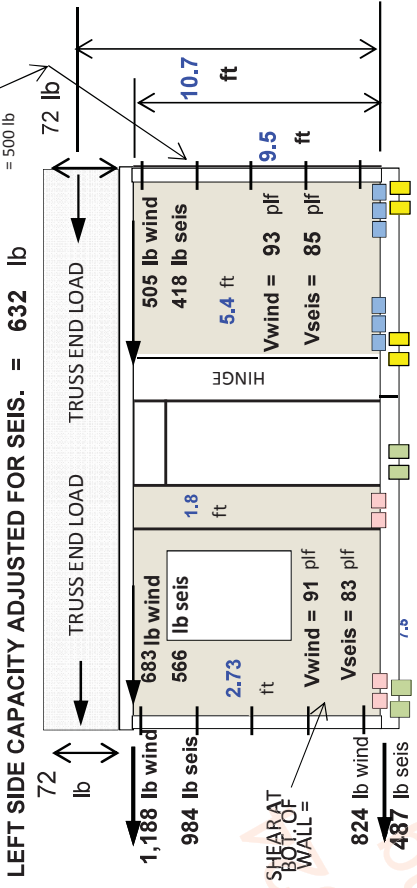

UPLIFT LOAD DISTRIBUTED OVER 10 " IN LVL RIM

CROSS-GRAIN TENSION CAP. OF LVL = 970 lb > 524 lb

HOLDDOWN REQUIREMENTS

1st fl weight + 72

3 (4.75) (7.5/2) = 1,049 lb → { 2 } UPPER PL use 2 (524 lb / pl)

731 lb → { 2 } LOW. PLATES use 2 (365 lb / pl)

EXTRA PLATE ON RIGHT SIDE TO ACCOMMODATE CENTRIPETAL FORCE DURING TRANSPORT

3 (4.75) (5.4/2) = 1,253 lb → { 2 } UPPER PL use 3 (418 lb / pl)

730 lb → { 1 } LOW. PLATES use 2 (365 lb / pl)

to satisfy interaction ratio

LEFT WALL

GABLE ROOF TRUSSES & WIND PERP. TO SLOPE DIR.

6 :12 SLOPE

FLOOR ANCHORS TO : CONCRETE W/ VERT. PL

from roof F2

O.K.

SEISMIC SHEAR = $\frac{\text{TRUSS END}}{\text{END}} = 130 + 93 (19/2) + 57 = 1075 = 72 \text{ plf} < 127 \text{ plf cap.}$

At bot. of wall controls.
Windows accounted for in wall test.

twice test
wall length

WIND SHEAR = $125 (19/2) = 1188 = 79 \text{ plf} < 349 \text{ plf cap.}$

SEIS. CATEGORY : E

O.K.

UPLIFT/LATERAL CAP. OF UPPER #10 ROW ON UPPER PL = 740 lb (185 lb x 4) → UPLIFT LOAD PER UPPER PL = 0 lb
 LATERAL CAP. OF LOWER #10 ROWS OF UPPER PL = 422 lb LATERAL LOAD PER UPPER PL = 86 lb
 UPLIFT CAP. OF LOWER #10 ROWS ON UPPER PL = 0 lb
 TOTAL TITEN SCREW UPLIFT CAPACITY OF LOWER PL = 1,317 lb
 TOTAL TITEN SCREW HORIZ. CAPACITY OF LOWER PL = 717 lb

UPPER ROW OF UPPER PL RESULTANT LOAD = 86 lb < 740 lb

FORCE TRANSFER AROUND OPENING METHOD	
WALL TEST: TOTAL WIND CAP. =	3474 lb
WALL TEST: TOTAL SEISMIC CAP. =	1264 lb

TOTAL WOOD SCREW UPLIFT & SHEAR CAP. OF LOWER PL = 1491 lb (212 lb x 7)
 TOTAL HORIZ. CAP. OF WALL-TO-FL TOE SCREWS = 1,685 lb
 % OF TOE SCREW LATERAL CAPACITY USED = 50 %

# UPPER BOXABL SHEAR PL'S REQ'D	= 0.8	USE [4]
INTERACTION RATIO OF LOWER SCREWS OF UPPER PL	= 0.20	
# LOW SHEAR PL'S REQ'D FOR WOOD SCREW SHEAR	= 1.3	USE [5]
LOW. H.D. PL TOT. RESULT. WOOD SCREW SHEAR	= 402 lb	
INTERACTION RATIO OF LOW. PL TITEN SCREWS	= 0.56	

ABOVE INTERACTION RATIOS INCLUDE SHEAR & UPLIFT FORCES

WIND
 Holddown = $1188 (9.5) + \frac{\text{net uplift} - .6(\text{wall wt})}{\text{length}} = -125 (19 / 2) - 3 (2.5) (9 / 2) = -524 \text{ lbs}$
 Force = $17.8 + 10 = -558 \text{ lbs}$

1st FL weight
 psf perp. trib par. trib

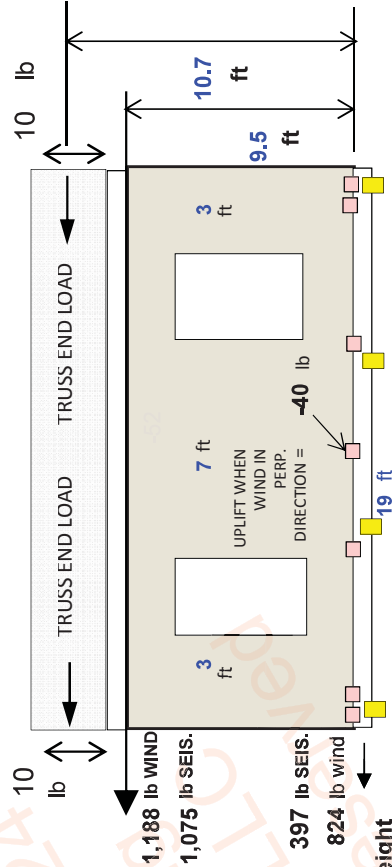

UPLIFT LOAD DISTRIBUTED OVER 9 " IN LVL RIM
 CROSS-GRAIN TENSION CAP. OF LVL = 870 lb > 0 lb

HOLDDOWN REQ'TS BOTH CORNERS

[0] UPPER PLATES → use [2] [0 lb / pl]
 [0] LOW. PLATES → use [1] [0 lb / pl]
 to satisfy interaction ratio



OPENING CORNER FORCES & SHEAR ABOVE & BELOW OPENINGS

WIND PARALLEL TO TRUSSES

SIDE WALLS

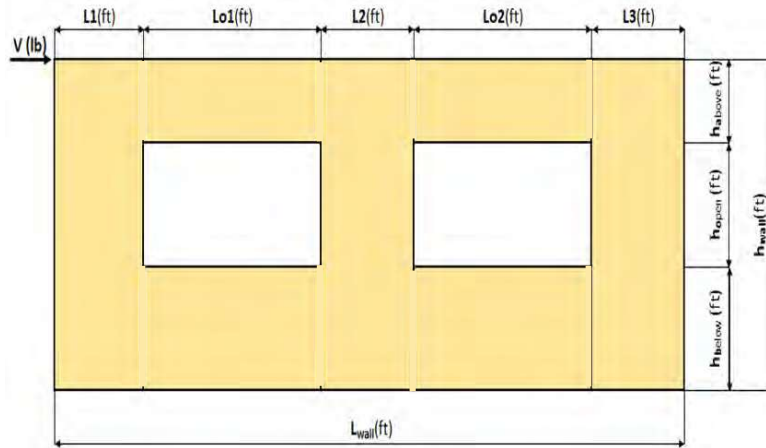

Shear Wall Calculation Variables

V	1276 lbf	Opening 1		Opening 2		Adj. Factor Method = 2bs/h	
L1	3.25 ft	ha1	1.50 ft	ha2	1.50 ft	Wall Pier Aspect Ratio Adj. Factor	
L2	6.50 ft	ho1	6.00 ft	ho2	6.00 ft	P1=ho1/L1=	1.85 N/A
L3	3.25 ft	hb1	2.00 ft	hb2	2.00 ft	P2=ho2/L2=	0.92 N/A
h _{wall}	9.50 ft	Lo1	3.00 ft	Lo2	3.00 ft	P3=ho3/L3=	1.85 N/A
L _{wall}	19.00 ft						

1. Hold-down forces: $H = Vh_{\text{wall}}/L_{\text{wall}} = 638 \text{ lbf}$

2. Unit shear above + below opening

First opening: $va1 = vb1 = H/(ha1+hb1) = 182 \text{ plf}$
 Second opening: $va2 = vb2 = H/(ha2+hb2) = 182 \text{ plf}$

3. Total boundary force above + below openings

First opening: $O1 = va1 \times (Lo1) = 547 \text{ lbf}$
 Second opening: $O2 = va2 \times (Lo2) = 547 \text{ lbf}$

4. Corner forces

$F1 = O1(L1)/(L1+L2) = 182 \text{ lbf}$
 $F2 = O1(L2)/(L1+L2) = 365 \text{ lbf}$
 $F3 = O2(L2)/(L2+L3) = 365 \text{ lbf}$
 $F4 = O2(L3)/(L2+L3) = 182 \text{ lbf}$

5. Tributary length of openings

$T1 = (L1 \cdot Lo1)/(L1+L2) = 1.00 \text{ ft}$
 $T2 = (L2 \cdot Lo1)/(L1+L2) = 2.00 \text{ ft}$
 $T3 = (L2 \cdot Lo2)/(L2+L3) = 2.00 \text{ ft}$
 $T4 = (L3 \cdot Lo2)/(L2+L3) = 1.00 \text{ ft}$

6. Unit shear beside opening

$V1 = (V/L)(L1+T1)/L1 = 88 \text{ plf}$
 $V2 = (V/L)(T2+L2+T3)/L2 = 109 \text{ plf}$
 $V3 = (V/L)(T4+L3)/L3 = 88 \text{ plf}$

Check $V1 \cdot L1 + V2 \cdot L2 + V3 \cdot L3 = V?$ 1276 lbf **OK**

7. Resistance to corner forces

$R1 = V1 \cdot L1 = 286 \text{ lbf}$
 $R2 = V2 \cdot L2 = 705 \text{ lbf}$
 $R3 = V3 \cdot L3 = 286 \text{ lbf}$

8. Difference corner force + resistance

$R1 - F1 = 103 \text{ lbf}$
 $R2 - F2 - F3 = -24 \text{ lbf}$
 $R3 - F4 = 103 \text{ lbf}$

9. Unit shear in corner zones

$vc1 = (R1 - F1)/L1 = 32 \text{ plf}$
 $vc2 = (R2 - F2 - F3)/L2 = -4 \text{ plf}$
 $vc3 = (R3 - F4)/L3 = 32 \text{ plf}$

OPENING CORNER FORCES & SHEAR ABOVE & BELOW OPENINGS

WIND PARALLEL TO TRUSSES

WINDOW
LEFT
OF
DOOR

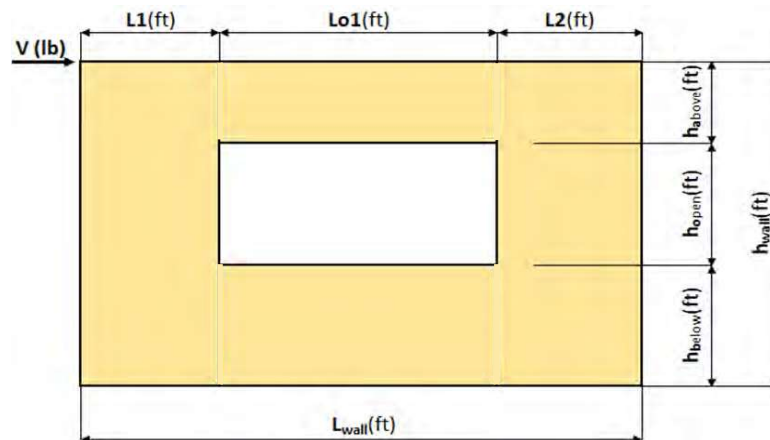

Shear Wall Calculation Variables

V	734 lbf	Opening 1	Adj. Factor Method =	2bs/h
L1	2.73 ft	ha1	Wall Pier Aspect Ratio	Adj. Factor
L2	1.77 ft	ho1	P1=ho1/L1=	2.20 0.975
h _{wall}	9.45 ft	hb1	P2=ho2/L2=	3.39 0.826
L _{wall}	7.50 ft	Lo1		

1. Hold-down forces: $H = Vh_{wall}/L_{wall} = 925 \text{ lbf}$

2. Unit shear above + below opening

First opening: $va1 = vb1 = H/(ha1+hb1) = 268 \text{ plf}$

3. Total boundary force above + below openings

First opening: $O1 = va1 \times (Lo1) = 804 \text{ lbf}$

4. Corner forces

$F1 = O1(L1)/(L1+L2) = 488 \text{ lbf}$

$F2 = O1(L2)/(L1+L2) = 316 \text{ lbf}$

5. Tributary length of openings

$T1 = (L1 \cdot Lo1)/(L1+L2) = 1.82 \text{ ft}$

$T2 = (L2 \cdot Lo1)/(L1+L2) = 1.18 \text{ ft}$

6. Unit shear beside opening

$V1 = (V/L)(L1+T1)/L1 = 163 \text{ plf}$

$V2 = (V/L)(T2+L2)/L2 = 163 \text{ plf}$

Check $V1 \cdot L1 + V2 \cdot L2 = V = 734 \text{ lbf}$ OK

7. Resistance to corner forces

$R1 = V1 \cdot L1 = 445 \text{ lbf}$

$R2 = V2 \cdot L2 = 289 \text{ lbf}$

8. Difference corner force + resistance

$R1 - F1 = -43 \text{ lbf}$

$R2 - F2 = -28 \text{ lbf}$

9. Unit shear in corner zones

$vc1 = (R1 - F1)/L1 = -16 \text{ plf}$

$vc2 = (R2 - F2)/L2 = -16 \text{ plf}$

OPENING CORNER FORCES & SHEAR ABOVE & BELOW OPENINGS

WIND PERPENDICULAR TO TRUSSES

SIDE WALLS

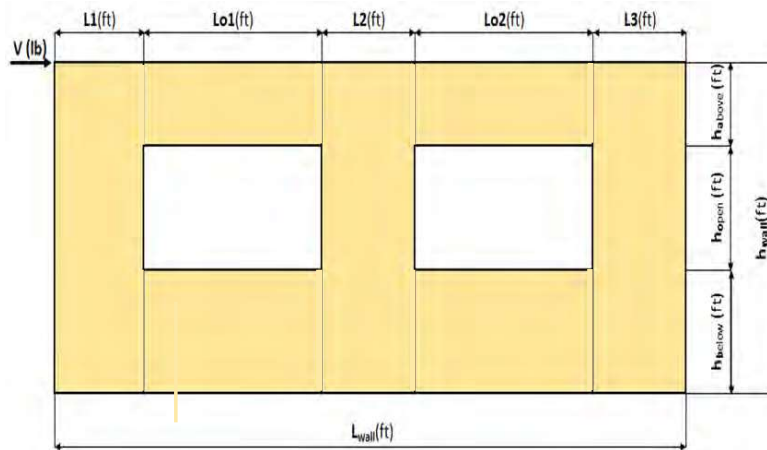

Shear Wall Calculation Variables

V	1188 lbf	Opening 1		Opening 2		Adj. Factor Method = 2bs/h	
L1	3.25 ft	ha1	1.50 ft	ha2	1.50 ft	Wall Pier Aspect Ratio Adj. Factor	
L2	6.50 ft	ho1	6.00 ft	ho2	6.00 ft	P1=ho1/L1=	1.85 N/A
L3	3.25 ft	hb1	2.00 ft	hb2	2.00 ft	P2=ho2/L2=	0.92 N/A
h _{wall}	9.50 ft	Lo1	3.00 ft	Lo2	3.00 ft	P3=ho3/L3=	1.85 N/A
L _{wall}	19.00 ft						

1. Hold-down forces: $H = Vh_{wall}/L_{wall}$ 594 lbf

2. Unit shear above + below opening

First opening: $va1 = vb1 = H/(ha1+hb1) = 170$ plf
 Second opening: $va2 = vb2 = H/(ha2+hb2) = 170$ plf

3. Total boundary force above + below openings

First opening: $O1 = va1 \times (Lo1) = 509$ lbf
 Second opening: $O2 = va2 \times (Lo2) = 509$ lbf

4. Corner forces

$F1 = O1(L1)/(L1+L2) = 170$ lbf
 $F2 = O1(L2)/(L1+L2) = 339$ lbf
 $F3 = O2(L2)/(L2+L3) = 339$ lbf
 $F4 = O2(L3)/(L2+L3) = 170$ lbf

5. Tributary length of openings

$T1 = (L1 \cdot Lo1)/(L1+L2) = 1.00$ ft
 $T2 = (L2 \cdot Lo1)/(L1+L2) = 2.00$ ft
 $T3 = (L2 \cdot Lo2)/(L2+L3) = 2.00$ ft
 $T4 = (L3 \cdot Lo2)/(L2+L3) = 1.00$ ft

6. Unit shear beside opening

$V1 = (V/L)(L1+T1)/L1 = 82$ plf
 $V2 = (V/L)(T2+L2+T3)/L2 = 101$ plf
 $V3 = (V/L)(T4+L3)/L3 = 82$ plf

Check $V1 \cdot L1 + V2 \cdot L2 + V3 \cdot L3 = V?$ 1188 lbf **OK**

7. Resistance to corner forces

$R1 = V1 \cdot L1 = 266$ lbf
 $R2 = V2 \cdot L2 = 656$ lbf
 $R3 = V3 \cdot L3 = 266$ lbf

8. Difference corner force + resistance

$R1 - F1 = 96$ lbf
 $R2 - F2 - F3 = -22$ lbf
 $R3 - F4 = 96$ lbf

9. Unit shear in corner zones

$vc1 = (R1 - F1)/L1 = 30$ plf
 $vc2 = (R2 - F2 - F3)/L2 = -3$ plf
 $vc3 = (R3 - F4)/L3 = 30$ plf

OPENING CORNER FORCES & SHEAR ABOVE & BELOW OPENINGS

WIND PERPENDICULAR TO TRUSSES

WINDOW
LEFT
OF
DOOR

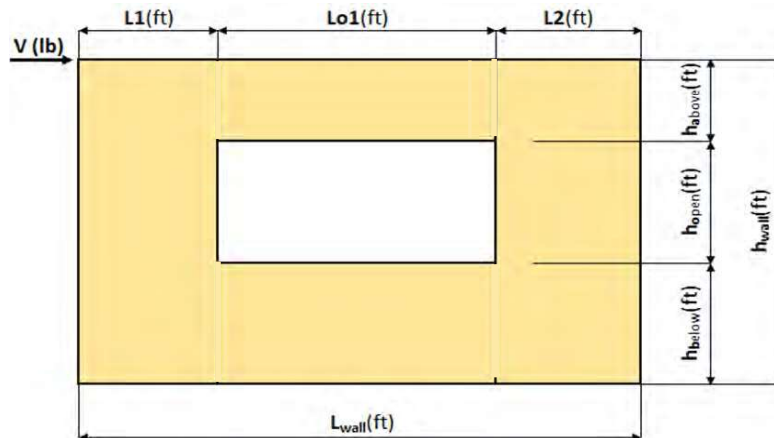

Shear Wall Calculation Variables

V	683 lbf	Opening 1	Adj. Factor Method =	2bs/h
L1	2.73 ft	ha1	Wall Pier Aspect Ratio	Adj. Factor
L2	1.77 ft	ho1	P1=ho1/L1=	2.20 0.975
h _{wall}	9.45 ft	hb1	P2=ho2/L2=	3.39 0.826
L _{wall}	7.50 ft	Lo1		

1. Hold-down forces: $H = Vh_{wall}/L_{wall} = 861 \text{ lbf}$

2. Unit shear above + below opening

First opening: $va1 = vb1 = H/(ha1+hb1) = 250 \text{ plf}$

3. Total boundary force above + below openings

First opening: $O1 = va1 \times (Lo1) = 749 \text{ lbf}$

4. Corner forces

$F1 = O1(L1)/(L1+L2) = 454 \text{ lbf}$

$F2 = O1(L2)/(L1+L2) = 294 \text{ lbf}$

5. Tributary length of openings

$T1 = (L1 \cdot Lo1)/(L1+L2) = 1.82 \text{ ft}$

$T2 = (L2 \cdot Lo1)/(L1+L2) = 1.18 \text{ ft}$

6. Unit shear beside opening

$V1 = (V/L)(L1+T1)/L1 = 152 \text{ plf}$

$V2 = (V/L)(T2+L2)/L2 = 152 \text{ plf}$

Check $V1 \cdot L1 + V2 \cdot L2 = V = 683 \text{ lbf}$ OK

7. Resistance to corner forces

$R1 = V1 \cdot L1 = 415 \text{ lbf}$

$R2 = V2 \cdot L2 = 269 \text{ lbf}$

8. Difference corner force + resistance

$R1 - F1 = -40 \text{ lbf}$

$R2 - F2 = -26 \text{ lbf}$

9. Unit shear in corner zones

$vc1 = (R1 - F1)/L1 = -15 \text{ plf}$

$vc2 = (R2 - F2)/L2 = -15 \text{ plf}$

CORNER FORCES

HIGHEST FOR TRUSSES PARALLEL TO WIND

734 lb < 1,737 lb ALLOWABLE

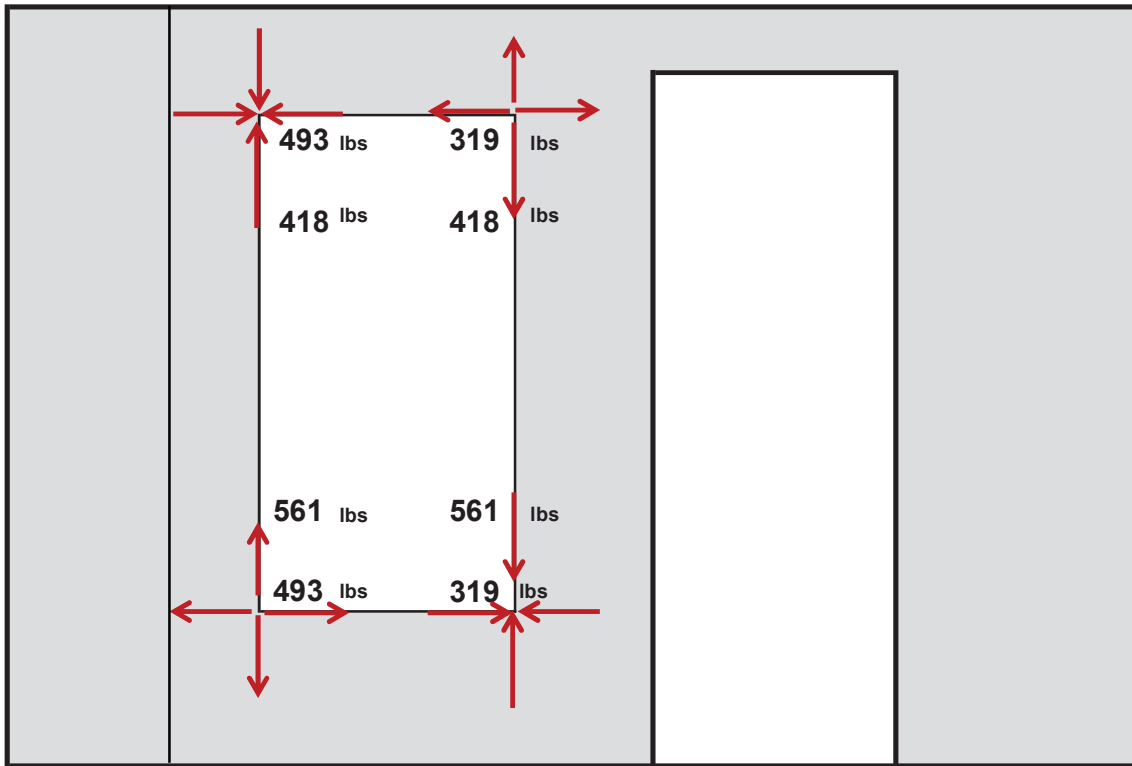

734 lb < 1,737 lb ALLOWABLE

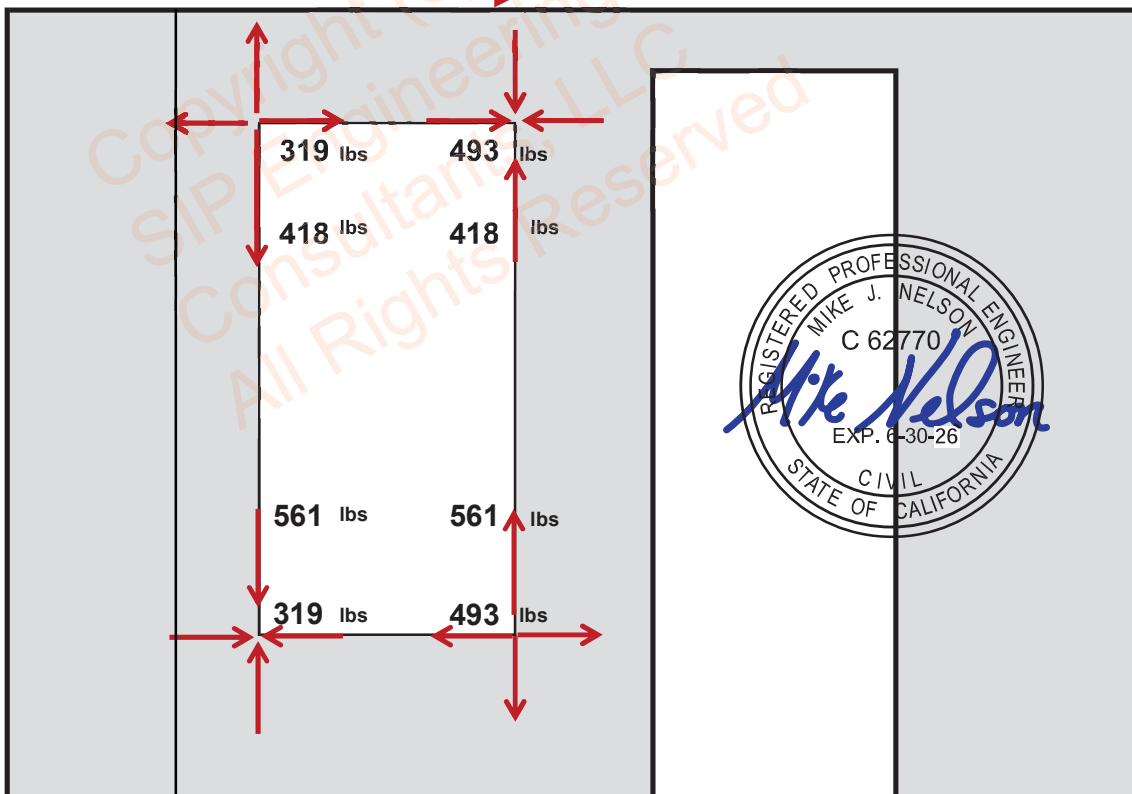

Racking Shear Wall Panel with Openings Load Test, ASTM E72-15, RADCO PROJECT # 236093.R

Load(lbs)	Deflection (in.)					Set (in.)				
	Panel #1 Steel 1	Panel #2 Steel 2	Panel #3 MgO 1	Panel #4 MgO 2	Average	Panel #1 Steel 1	Panel #2 Steel 2	Panel #3 MgO 1	Panel #4 MgO 2	Average
0	0.0000	0.0000	0.0000	0.0000	0.0000	0.0000	0.0000	0.0000	0.0000	0.0000
1000	0.0458	0.1620	0.0253	0.1056	0.0847	0.0013	-0.0054	-0.0040	-0.0071	-0.0038
2000	0.0764	0.2693	0.0629	0.1905	0.1498	0.0032	0.0002	-0.0004	-0.0019	0.0003
3000	0.1088	0.3784	0.0972	0.3006	0.2213	0.0065	0.0099	0.0031	0.0070	0.0066
4000	0.1511	0.5190	0.1364	0.4471	0.3134	0.0084	0.0190	0.0049	0.0141	0.0116
5000	0.2386		0.1847		0.2117	0.0223		0.0107		0.0165
6000										
Ultimate	5669	4825	5540	4814	5212.0					

↔ 5,212 / 3 = 1,737 lb ALLOWABLE

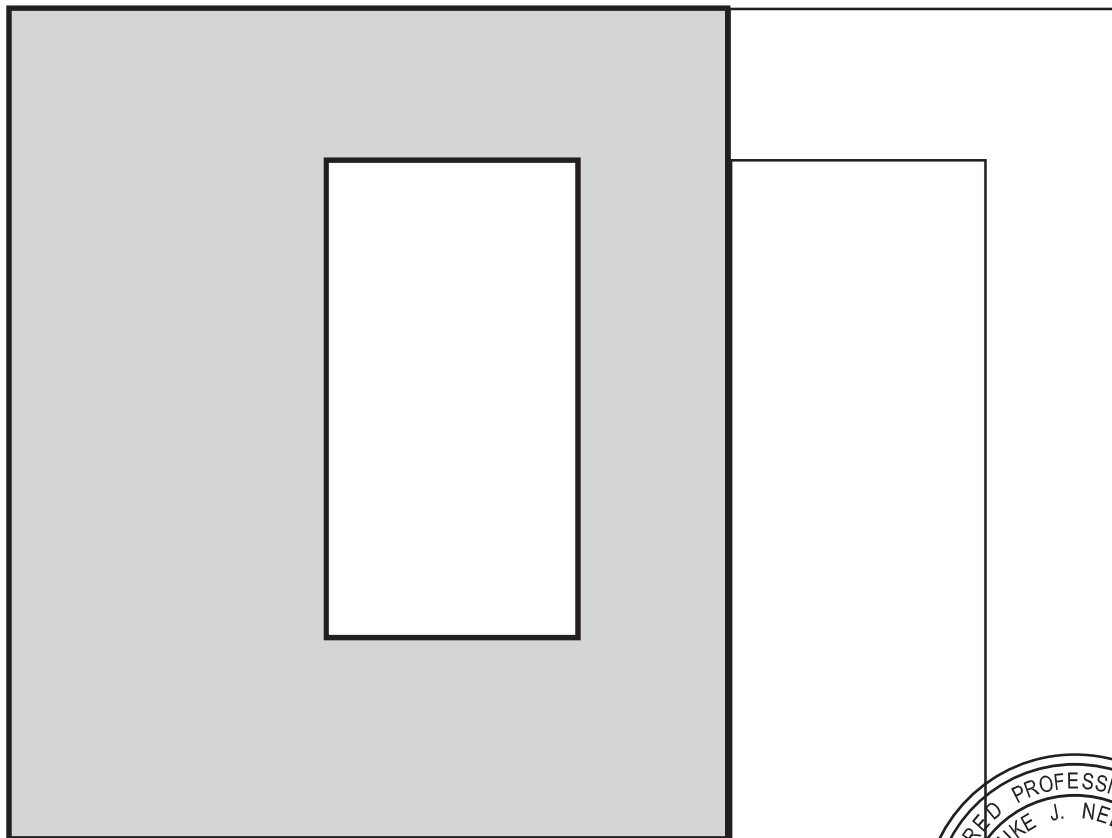



Racking Shear Single Panel Load Test, ASTM E72

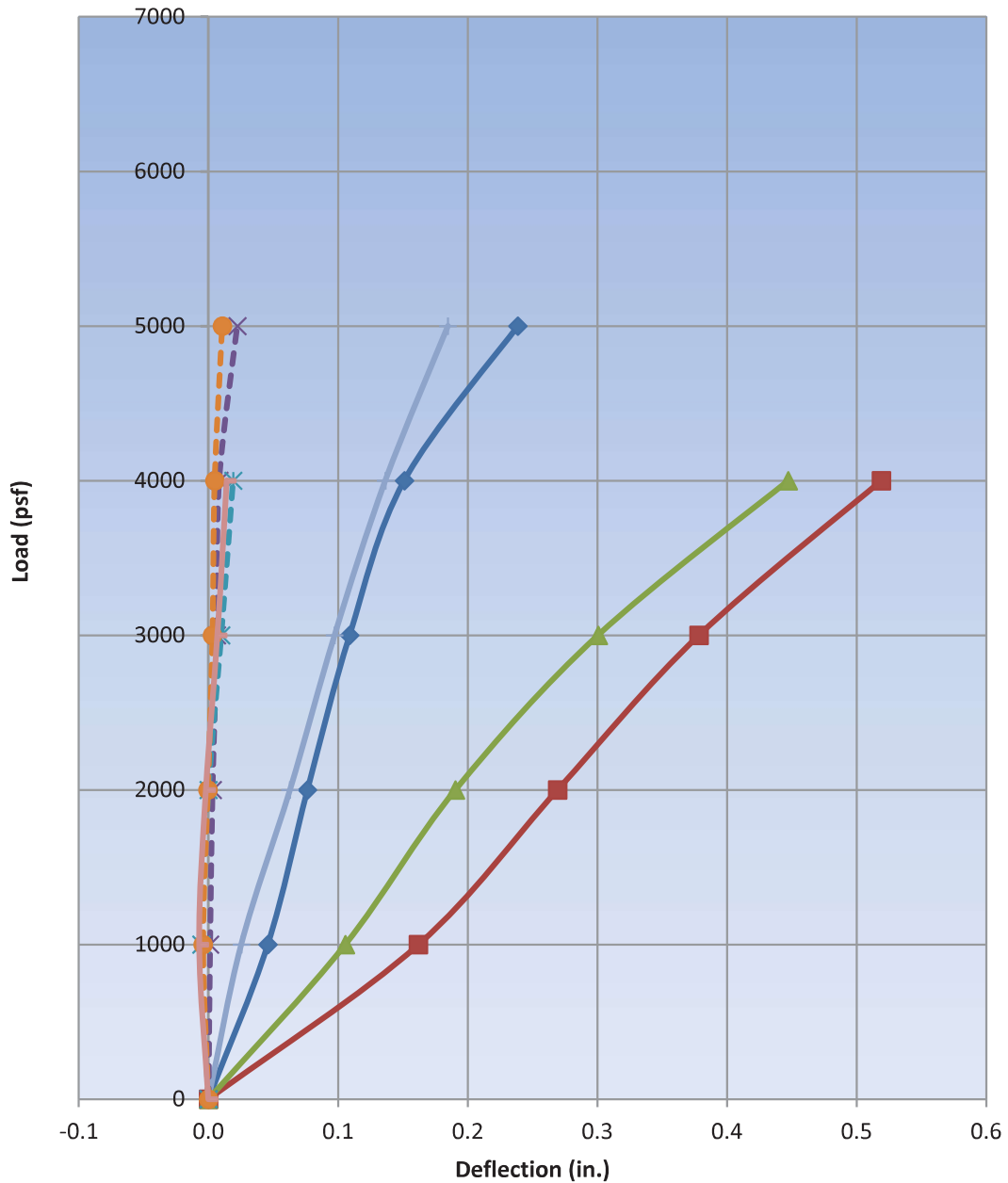
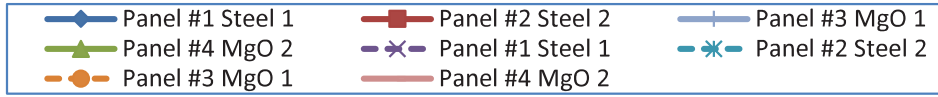

TENSION / BENDING ANALYSIS OF FLOOR EDGE AT HOLDDOWNS

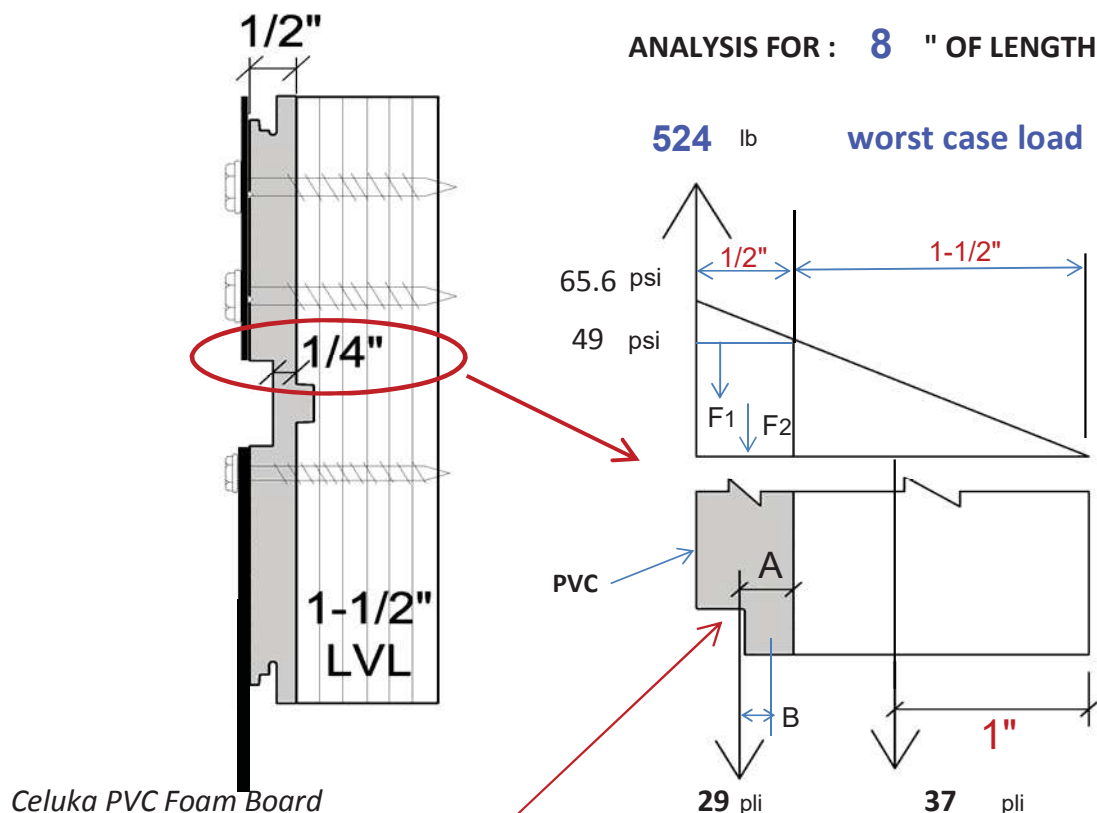

PVC SECTION MODULUS =	0.011	in ³ / in	F1 =	4	pli
DIRECT PVC TENSION STRESS =	115	psi	F2 =	25	pli
ALLOW. PVC TENSILE STRESS =	2,320	psi	A =	0.262	in.
PVC BENDING MOMENT =	4	lb-in / in	B =	0.137	in.
PVC BENDING STRESS =	367	lb-in	LVL SECTION MODULUS =	0.26	in ³ / in
ALLOW. PVC BENDING STRESS =	2,030	psi	DIRECT LVL STRESS =	30	psi
<u>TENSION</u> + <u>BENDING</u> =	0.23		LVL BENDING MOMENT =	9	lb-in / in
ALLOW TENS.	ALLOW BEND.		LVL BENDING STRESS =	35	psi
			DIRECT + BEND. STRESS =	65	psi < 97 psi CAPACITY
					OK

* 291 psi / 3 F.O.S. = 97 psi (For Radiata Pine LVL, BUT Doug. Fir LVL is being used, which is stronger than Radiata Pine)
 Based on testing by the University of Canterbury

IF PVC RESISTS ALL LOAD BY ITSELF FOR 11 " LONG PIECE

DIRECT PVC TENSION STRESS =	191	psi
ALLOW. PVC TENSILE STRESS =	2,149	psi
PVC BENDING MOMENT =	197	lb-in
PVC BENDING STRESS =	1,670	psi
ALLOW. PVC BENDING STRESS =	3,884	psi
<u>TENSION</u> + <u>BENDING</u> =	0.52	
ALLOW TENS.	ALLOW BEND.	



ALSO, TRIPLE TESTED
 w/ AN AVE. FAILURE
 LOAD = 3,800 lb

WALLS: COMBINED AXIAL & BENDING (SEISMIC CAT. A, B, C)

LOAD CASE 1 : DL +.75 LL + .75 WL	RLL = 20 psf	WIND = 21 psf (C&C CORNERS)
LOAD CASE 2 : DL + WL	DL = 26 psf	= 17.9 (C&C)
LOAD CASE 3 : WIND ONLY (C & C)	ROOF SL, pf = 14 psf	= 10.0 (MWFRS)

LOAD CASE 1 - ITERATED P-DELTA ADJUSTED MWFRS WIND LOAD = 12.2 psf

LOAD CASE 1

AXIAL LOAD = 24 + $\left(\frac{DL}{2} + .75 LL \right) \left(\frac{22}{2} \right) \left(\frac{3}{1.50} \right)$ = $\frac{954 \text{ plf}}{2200 \text{ plf allow.}}$ = 0.43 < 1 O.K.

.75 P-delta ADJUSTED WIND LOAD = $9.1 \left(\frac{3}{1.50} \right)$ = $\frac{18 \text{ psf}}{37 \text{ psf allow.}}$ = 0.49 < 1 O.K.

0.93 < 1 O.K.

LOAD CASE 2

AXIAL LOAD = 24 + $\left(\frac{DL}{2} \right) \left(\frac{22}{2} \right) \left(\frac{3}{1.50} \right)$ = $\frac{624 \text{ plf}}{2200 \text{ plf allow.}}$ = 0.28 < 1 O.K.

DL Pdelta adjusted WIND LOAD = $11.3 \left(\frac{3}{1.50} \right)$ = $\frac{23 \text{ psf}}{37 \text{ psf allow.}}$ = 0.61 < 1 O.K.

0.89 < 1 O.K.

BEAM DOES NOT SUPPORT TRUSSES

IE SIP = 44,880,000 lb-in² = 96% of total
 IE LVL = 1,968,750 lb-in²
 IE tot = 46,848,750 lb-in²

Portion of load absorbed by sip. Remainder absorbed by internal LVL

TRIB. WIDTH / EFFECT. BEND. WIDTH

LOAD CASE 3

AVE. C & C WIND LOAD = $(0.96) 19.4 \left(\frac{3}{1.52} \right)$ = $\frac{37 \text{ psf}}{37 \text{ psf allow.}}$ = 0.99 < 1 O.K.

AT THE 3' TRANSITION PT NEXT TO 3' WIDE WINDOW LVL BENDING MOM.= 28 lb-ft < 317 lb-ft CAP. **OK**

BET. DOOR & WINDOW

LOAD CASE 1

AXIAL LOAD = 24 + $\left(\frac{DL}{2} + .75 LL \right) \left(\frac{22}{2} \right) \left(\frac{4.8}{1.8} \right)$ = $\frac{1271 \text{ plf}}{8867 \text{ plf allow.}}$ = 0.14 < 1 O.K.

.75 P-delta ADJUST. WIND LOAD = $(0.54) 9.1 \left(\frac{5}{1.8} \right)$ = $\frac{13 \text{ psf}}{37 \text{ psf allow.}}$ = 0.36 < 1 O.K.

0.50 < 1 O.K.

LOAD CASE 2

AXIAL LOAD = 24 + $\left(\frac{DL}{2} \right) \left(\frac{9.5}{2} \right) \left(\frac{4.8}{1.8} \right)$ = $\frac{395 \text{ plf}}{8867 \text{ plf allow.}}$ = 0.04 < 1 O.K.

DL Pdelta adjusted WIND LOAD = $(.54) 11.3 \left(\frac{4.8}{1.8} \right)$ = $\frac{16 \text{ psf}}{37 \text{ psf allow.}}$ = 0.44 < 1 O.K.

0.48 < 1 O.K.

BEAM DOES NOT SUPPORT TRUSSES

IE SIP = 52,958,000 lb-in² = 54% of total
 IE LVL = 44,494,000 lb-in² = 46% of total
 IE tot = 97,452,600 lb-in²

TRIB. WIDTH / EFFECT. BEND. WIDTH

LOAD CASE 3

C & C WIND LOAD = $(0.54) 17.9 \left(\frac{4.8}{1.8} \right)$ = $\frac{26 \text{ psf}}{37 \text{ psf allow.}}$ = 0.70 < 1 O.K.

LVL Moment = 446 lb-ft < 1,912 lb-ft **OK**

LVL STRENGTH CALC

Fb = 2900 psi
 S = 7.91 in³
 MOM = 1,912 lb-ft
 AXIAL = 12000 lb

LOAD CASE 1 : DL +.75 LL + .75 WL	RLL = 20 psf	WIND = 21 psf (C&C CORNERS)
LOAD CASE 2 : DL + WL	DL = 26 psf	= 17.9 (C&C)
LOAD CASE 3 : WIND ONLY (C & C)	ROOF SL, pf = 14 psf	= 10.0 (MWFRS)

LOAD CASE 1 - ITERATED P-DELTA ADJUSTED MWFRS WIND LOAD = 12.2 psf

LOAD CASE 1

$$\text{AXIAL LOAD} = 105 + \left(\begin{matrix} \text{DL} \\ 26 \end{matrix} + \begin{matrix} .75 \text{ LL} \\ 15 \end{matrix} \right) \left(\frac{21}{2} \right) \left(\frac{9.5}{6.5} \right) = \frac{785 \text{ plf}}{8867 \text{ plf allow.}} = 0.09 < 1 \quad \text{O.K.}$$

SIDE WALLS BELOW STEEL BM

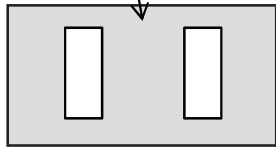

.75 P-delta ADJUSTED WIND LOAD = 9.1 $\left(\frac{9.5}{6.5} \right) = \frac{13 \text{ psf}}{37 \text{ psf allow.}} = 0.36 < 1 \quad \text{O.K.}$

0.45 < 1 O.K.

LOAD CASE 2

$$\text{AXIAL LOAD} = 105 + \left(\begin{matrix} \text{DL} \\ 26 \end{matrix} \right) \left(\frac{21}{2} \right) \left(\frac{9.5}{6.5} \right) = \frac{555 \text{ plf}}{8867 \text{ plf allow.}} = 0.06 < 1 \quad \text{O.K.}$$

DL Pdelta adjusted WIND LOAD = 11.3 $\left(\frac{9.5}{6.5} \right) = \frac{17 \text{ psf}}{37 \text{ psf allow.}} = 0.45 < 1 \quad \text{O.K.}$

0.51 < 1 O.K.

LOAD CASE 3

AVE. C & C WIND LOAD AT THE 3' TRANSITION PT NEXT TO 3' WIDE WINDOW = 19.4 $\left(\frac{9.5}{6.5} \right) = \frac{28 \text{ psf}}{37 \text{ psf allow.}} = 0.77 < 1 \quad \text{O.K.}$



WALL SUPPORTING CARPORT

CASITA ROOF DL + .75 SL

LOAD CASE 1

$$\text{AXIAL LOAD} = 128 + \left(\begin{matrix} \text{CARPORT LOAD DL} \\ 26 \end{matrix} + \begin{matrix} .75 \text{ LL} \\ 15 \end{matrix} \right) \left(\frac{14}{2} \right) \left(\frac{2.5}{2} \right) = \frac{521 \text{ plf}}{2200 \text{ plf allow.}} = 0.24 < 1 \quad \text{O.K.}$$

.75 P-delta ADJUSTED WIND LOAD = 9.1 $\left(\frac{2.5}{2} \right) = \frac{11 \text{ psf}}{37 \text{ psf allow.}} = 0.31 < 1 \quad \text{O.K.}$

0.55 < 1 O.K.

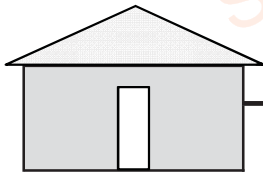

LOAD CASE 2

CASITA ROOF DL

$$\text{AXIAL LOAD} = 94 + \left(\begin{matrix} \text{DL} \\ 26 \end{matrix} \right) \left(\frac{14}{2} \right) \left(\frac{2.5}{2} \right) = \frac{347 \text{ plf}}{2200 \text{ plf allow.}} = 0.16 < 1 \quad \text{O.K.}$$

DL Pdelta adjusted WIND LOAD = 11.3 $\left(\frac{2.5}{2} \right) = \frac{14 \text{ psf}}{37 \text{ psf allow.}} = 0.38 < 1 \quad \text{O.K.}$

0.54 < 1 O.K.

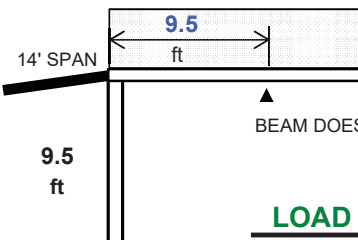

LOAD CASE 3

C & C WIND LOAD = 17.9 $\left(\frac{2.5}{2} \right) = \frac{22 \text{ psf}}{37 \text{ psf allow.}} = 0.60 < 1 \quad \text{O.K.}$

ALLOWABLE AXIAL LOAD ANALYSIS IN SEISMIC CATEGORY D & E

ALLOW. AXIAL LOAD IN CAT. A, B, C = **2,200** lb

MAX. ACTUAL SHEAR AT
HIGH END OF CAT. C = **49** plf

ALLOW. SHEAR IN CAT. D, E = **127** plf

DIFF. BET. HIGHEST POSSIBLE SHEAR = **78** plf
IN CAT. C AND ALLOW. SHEAR IN CAT. D

DIFFERENCE IN AXIAL CAPACITY = **1,958** lb

ACTUAL SHEAR = **90** plf



ADJUSTED ALLOWABLE AXIAL LOAD

$$= 242 \text{ lb} + \frac{(127 \text{ plf} - \text{ACTUAL SHEAR}) (1,958 \text{ lb})}{78 \text{ plf}} = \boxed{1171 \text{ plf}}$$

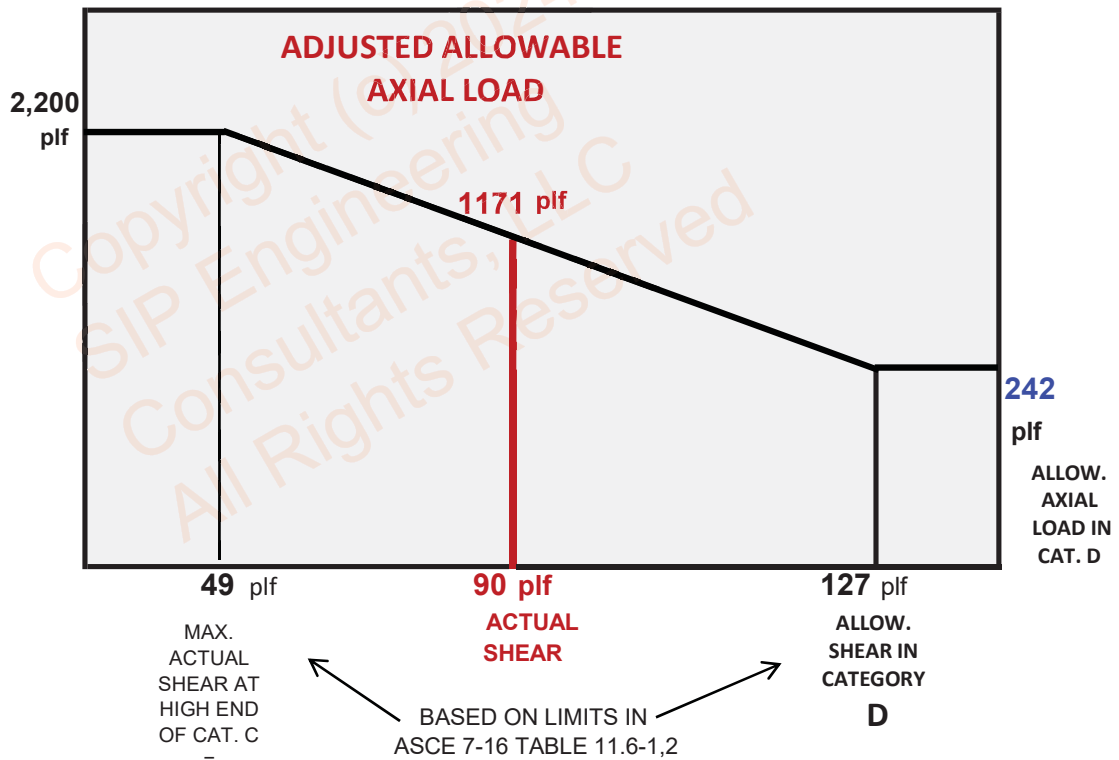

WALLS SUPPORTING TRUSSES - AXIAL CHECK IN SEISMIC CATEGORIES D, E

LOAD CASE 1 : DL + .75 SL

DL = 26 psf

EAVE OVERHANG = 1.5 ft

ROOF SL, pf = 14 psf

$$\text{AXIAL LOAD} = 24 + \left(\overset{\text{DL}}{26} + \overset{.75 \text{ SL}}{11} \right) \left(\frac{22}{2} \right) \left(\overset{\text{TRIB. MULT.}}{\frac{3}{1.5}} \right) = \frac{855 \text{ plf}}{1171 \text{ plf allow.}} = 0.73 < 1 \quad \text{OK}$$

WALL SEGMENT NEXT TO WINDOW

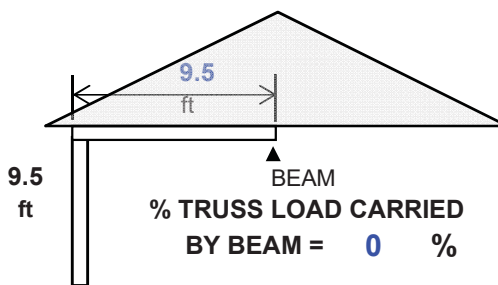
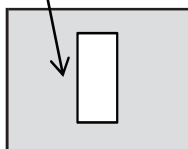

BET. DOOR & WINDOW

$$\text{AXIAL LOAD} = 24 + \left(\overset{\text{DL}}{26} + \overset{.75 \text{ SL}}{11} \right) \left(\frac{22}{2} \right) \left(\frac{4.8}{1.8} \right) = \frac{1139 \text{ plf}}{1171 \text{ plf allow.}} = 0.97 < 1 \quad \text{O.K.}$$

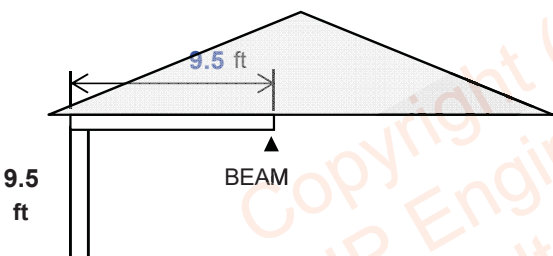
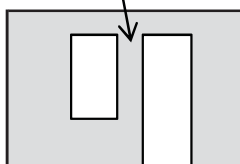

$$\text{AXIAL LOAD} = 105 + \left(\overset{\text{DL}}{26} + \overset{.75 \text{ SL}}{11} \right) \left(\frac{22}{2} \right) \left(\frac{9.5}{6.5} \right) = \frac{743 \text{ plf}}{1171 \text{ plf allow.}} = 0.63 < 1 \quad \text{O.K.}$$

HINGE BEAM DL REACTION

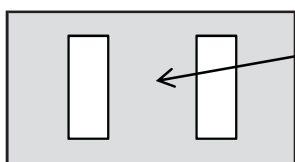

SIDE WALLS BELOW STEEL BM

SCREW ANALYSIS AT ROOF EDGES

COMPONENT WIND LOAD AT WALL CORNERS: 18.9 psf
COMPONENT WIND LOAD - MIDDLE WALL: 16.1 psf
MWFRS WIND LOAD ON WALL: 9.9 psf
 WALL HEIGHT: 9.5 ft

C & C REACTION AT TOP OF WALL AT CORNERS: 90 plf
C & C REACTION AT TOP OF WALL - MIDDLE: 77 plf
MWFRS REACTION AT TOP OF WALL : 47 plf
MWFRS ROOF DIAPH. REACTION PARALLEL TO TRUSSES: 59 plf
 ROOF DIAPHRAGM REACTION SHEAR PERP. TO TRUSSES: 63 plf
 ALLOW. SIP SCREW SHEAR CAP. THRU 1/8" PVC : 102 lb
 ALLOW. SIP SCREW SHEAR CAP. IN LVL : 431 lb
 % WALL REACTION ABSORBED BY LOWER PVC PIECE : 0%
 % WALL REACTION ABSORBED BY SCREWS : 100%

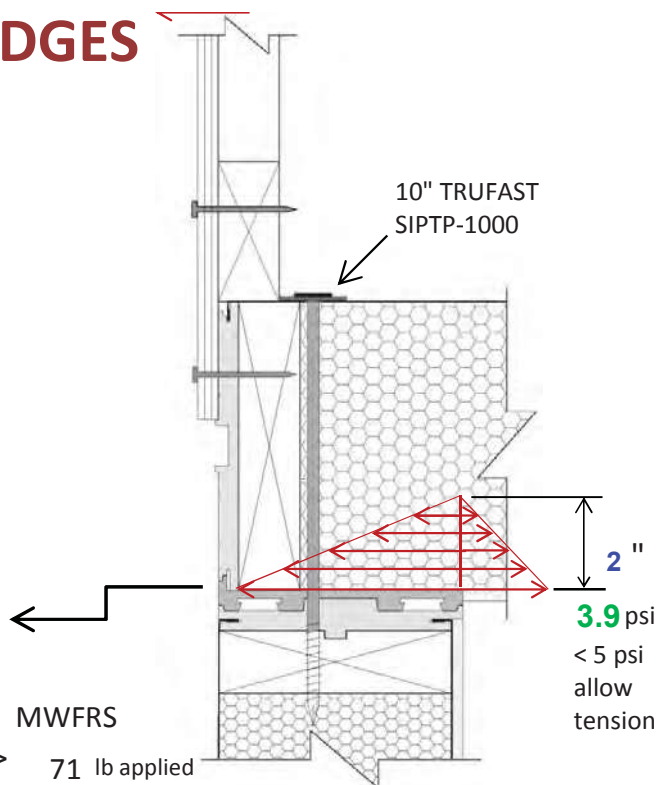

EPS SHEAR/TENSION
 INTERACTION RATIO = 0.82 < 1 **OK**
 EPS SHEAR = 0.85 psi < 6 psi

APPLIED UPLIFT AT TRUSS END = 348 lb = 174 plf
 NET UPLIFT AT TRUSS END = 210 lb = 105 plf

NET UPLIFT REACTION AT WALLS PARALLEL TO TRUSSES: 58 plf MWFRS
SCREW SPACING = 14.3" oc

NET TRUSS UPLIFT REACTION - .6 SIP ROOF WT: 100 plf MWFRS → -10 plf at BOT. of wall
 NET TRUSS UPLIFT REACTION - .6 SIP ROOF WT: 94 plf MWFRS (WHEN TRUSSES PERP. TO L & R WALLS)
 46 plf at BOT. of wall

WITHDRAWAL CAPACITY OF SIP SCREW : 336 lb = 140 lb/in (1.5")(Cd=1.6)

FROM DR. J DATA

<i>C & C values do not apply to analysis involving concurrent loads from 2 orthogonal surfaces, therefore only MWFRS values are used in the interaction equation</i>	MWFRS DIAPHRAGM SHEAR RATIO	C & C SHEAR RATIO	MWFRS PULL-OUT RATIO	MWFRS WALL REACTION SHEAR RATIO	MWFRS INTERACTION RATIO OF PORTION IN WOOD
CORNER OF WALLS PERP. TO TRUSSES :	0.17	0.25	0.36	0.13	0.53
CORNER OF WALLS PARALLEL. TO TRUSSES :	0.16	0.25	0.21	0.00	0.37



ROOF DIAPHRAGM ANALYSIS

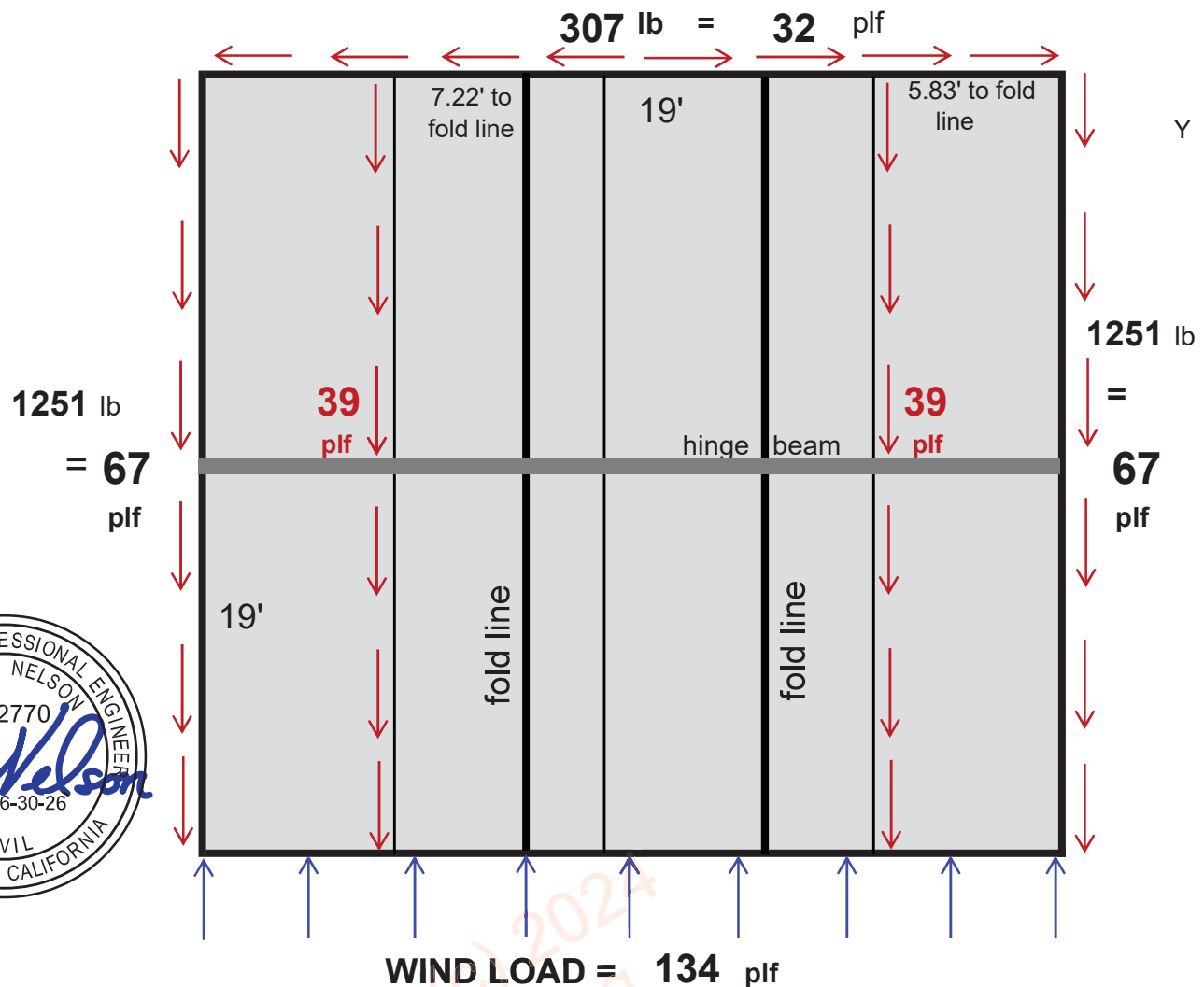

43% OF LOAD APPLIED TO ROOF TRUSSES HAVING THEIR OWN DIAPHRAGM WHICH PROVIDES REDUNDANCY THAT IS CONSERVATIVELY IGNORED

SHEAR ACROSS RIGHT FOLD LINE = 468 lb

CHORD FORCE ACROSS LEFT FOLD LINE = 291 lb

CHORD FORCE ACROSS RIGHT FOLD LINE = 264 lb (RESISTED BY FOLD-LINE HINGE)

The roof and floor diaphragm are constructed similar to the walls, but are thicker. Therefore, it's reasonable to assume the roof and floor diaphragms would have an in-plane shear capacity equal to, or greater, than the wall shear capacity of 349 plf.

As can be seen from the above analysis, the actual shear at the roof/floor diaphragm joint is FAR below 349 plf - clearly too small to worry about.



LOAD CAPACITIES OF STEEL HINGE BEAMS AT ROOF AND FLOOR

3.4 Test Results

Results from testing are provided in the table below.

Beam Depth / Span (in. / in.)	Specimen Description	Specimen Number	Ultimate Load (lbs)	Failure Mode
7 / 223	Floor	147899	12,418	Pin sheared at the tip with bending of the shank
		147900	12,339	Pin sheared at the tip with bending of the shank, and a broken tab
		147901	12,755	Pin sheared at the tip with bending of the shank
	Roof	147903	15,660	Pin sheared at the tip with bending of the shank. (Left side)
		147904	17,515	Pin sheared at the tip with bending of the shank. (Left side)
		147905	16,451	Pin sheared at the tip with bending of the shank. (Left side)

NOTE: BECAUSE ROOF TRUSSES ARE USED, THE SIP ROOF WON'T EXPERIENCE SNOW OR LIVE LOAD, AND, SINCE THE FLOOR BEAM HAS INTERIOR SUPPORT, THE BEAMS WILL HAVE FAR MORE STRENGTH THAN THEY NEED.

3.5 Summary and Conclusions

Specimen Description	Average Ultimate Load (lbs)	Load at each load Cell ¹ (lbs)
Floor I Beam	12,504	1,563
Roof I Beam	16,542	2,067

¹Load at each loading point was determined by taking the average ultimate load and dividing by the 8 evenly spaced load points

Equivalent roof uniform loading = 114 psf
(F.O.S. = 3.17 for max. allowed 31 psf snow load)

Equivalent floor uniform loading = 87 psf
(F.O.S = 1.93 for total load)

STEEL MATERIAL PROPERTIES:

HINGE BEAM: ASTM A36 (MIN. Fy = 36 ksi, MIN. Ft_u = 58 ksi)

HINGE : ASTM A572 GR. 50 (MIN. Fy = 50 ksi, MIN. Ft_u = 65 ksi)

HINGE BEAM PINS: H900 HARDENED S17400 S.S.

(MIN. Fy = 170 ksi, MIN. Ft_u = 190 ksi)



Table 2: Axial Load Capacity^{1,2}

Panel Configuration	Allowable Load (plf)
113.875-inch Wall Height	2200

For SI: 1 inch=25.4 mm, 1 plf = 14.59 N/m.

¹Tabulated axial load is the maximum uniform load (pounds per linear foot) applied concentrically to the full thickness of the SIP, including facings, to the top. Eccentric axial loading to one face of the SIP is outside the scope of this report.

²For combined loading, the requirements of Section 4.1 must be applied.

Table 3: Seismic Design Categories A, B, and C Shearwall Racking Load Capacity¹

Panel Configuration	Allowable Load (plf)
113.875-inch Wall Height	349

For SI: 1 inch=25.4 mm, 1 plf = 14.59 N/m.

¹Shearwall capacity limited to walls with a 1:1 (h:w) aspect ratio.

²This shearwall design is limited to use in Seismic Design Categories A, B, and C.

**Table 4: Seismic Design Categories A through F Shearwall Racking Load Capacity¹**

Panel Configuration	Allowable Load (plf)
113.875-inch Wall Height	127

For SI: 1 inch=25.4 mm, 1 plf = 14.59 N/m.

¹Shearwall capacity limited to walls with a 1:1 (h:w) aspect ratio.

²Axial capacity of shearwalls used in Seismic Design Categories D, E, and F is limited to 11% of the value in Table 2.

³The deflection at allowable shear load is 0.25 inches (6 mm).

Taken from ICC-ESR 4275

Table 1: Transverse Load Capacity (psf)

Panel Configuration	L/180	L/240	L/360
Floor and Roof Panel, Positive Wind Load^{1,3} (113.875-inch long)	31.3	31.3	31.3
Floor and Roof Panel, Negative Wind Load^{2,3} (113.875-inch long)	86.7	86.7	63.5
Wall Panel, Positive Wind Load^{1,4} (113.875-inch long)	38.3	38.3	38.3
Wall Panel, Negative Wind Load^{2,4} (113.875-inch long)	36.6	36.6	36.6

For SI: 1 inch=25.4 mm, 1 psf= 47.88 Pa.

¹Positive wind load direction indicates force applied to the metal facing of the panel (outside surface) towards the MgO facing of the panel (inside surface).

²Negative wind load direction indicates force applied to the MgO facing of the panel (inside surface) towards the metal facing of the panel (outside surface).

³Roof and floor panels are supported with 3 inches of bearing on one end and 6 inches bearing on the other end.

⁴Wall panel allowable loads are based on panels supported through the end caps.

