

**Approved For State of California
Factory Built Housing**

By

MA Consulting & Engineering MACE, LLC.
Third Party Design Approval Agency (DAA)
Certificate Number: DF1570823

These plans have been approved pursuant to the provisions of The State of California Health and Safety Code, Division 13, Part 6 and California Code of Regulations, Title 25, Chapter 3, Subchapter 1

Approval herein does not authorize or approve any omission or deviation from State laws or valid local ordinances nor it is applicable to movement of units over highways, county roads or city streets.

Generic Foundation Design Approved

Occupancy	Roof LL	Wind	Exp	Seismic Cat
R3	20 psf	115	C	E

Plan Approval No. **MAC-FBH 10153**

By: **Mohsen Anis**

Approval Date: **1/11/2025**

Expiration Date: **1/11/2028**

BOXABL

BOXABL INC.

BXB-000012

Climate Zone 8

STATE OF CALIFORNIA SUPPLEMENTAL DOCUMENT



BOXABL
+1(702) 500-9000
www.boxabl.com

Service Hours:
Mon - Fri | 5 AM - 6 PM PST
Sat | 5 AM - 5 PM PST

5345 East North Belt Rd,
North Las Vegas, NV,
89115, USA

This document has been created specifically for the State of California Climate Zone 8.

The intended use of this document is to support/validate the designs/materials and uses of BOXABL modules as outlined in the plan sets. This document includes calculations and justifications for various aspects of the home such as HVAC load & energy calculations, testing reports to validate uses of materials specific to BOXABL, as well as an outline of the materials used in the construction.

Please direct any questions regarding this document/it's comments to engineering@boxabl.com

Contents – BOXABL Inc. State of California BXB-000012 Climate Zone 8
Supplemental Documents

- 1.0 Energy 1
 - 1.1 Title 24 Report 1
 - 1.2 Insulation Test Report 16
- 2.0 SIP Panel Listing Report 22
- 3.0 Building Components..... 43
 - 3.1 Window Installation Test Report..... 43
 - 3.2 Jeld-Wen Installation Approval 56
 - 3.3 Window DP Rating Chart 61
 - 3.4 Window Jeld-Wen Chart..... 62
 - 3.5 Doors BEE Report..... 65
 - 3.6 Doors Intertek Fire Report..... 70
- Equipment..... 90
 - 4.0 HVAC..... 90
 - 4.1 LG Model # Cut Sheet..... 90
 - 4.2 Bath Ventilation Fan..... 93
 - 4.3 ECO-PAIR+ Single Room ERV 94
 - 5.0 Plumbing..... 96
 - 5.1 Shower Surround 96
 - 5.2 Tub / Shower Specs..... 98
 - 5.3 Water Heater Model # Cut Sheet 100
 - 5.4 Toilet..... 104
 - 6.0 Electrical 106
 - 6.1 Electrical Connectors..... 106
 - 6.2 Astronomical Switch..... 109
 - 6.3 Smoke / CO2 Detector 115

7/19/24

Job# 32703 JH

CONSERVATION FOR THE CALIFORNIA LIFESTYLE

Kyle Denman
 Boxabl, Inc.
 5345 East North Belt Road
 North Las Vegas, NV 89115
 702-491-2051
 CBECC v3.0
 Re: BXB12 in California



CL&E

A Division of Builder Services Network
 Title 24 Compliance-Residential/Non-Residential
 2937 Veneman Ave, Suite C275
 Modesto, CA 95356
 Ph: 209-618-4462 Fx: 209-846-9796

2022 Code Compliance

	CBC Climate Zone	8	
	EDR Efficiency EDR Total	0.2 / 0.1	
	EDR Source	1.0	
	Photovoltaic	-	
	Plan Name	Studio	
	File Name	BX361C8	
	Square Footage	361	
	Number of Stories	1	
	Glazing Percentage	19.94%	
Envelope	Roofing Material	Built Up	
	Reflectance/Emittance	0.20 / 0.89	
	Ceiling	R-41	
	Above Roof Deck	R-10	
	Below Roof Deck	-	
	Radiant Barrier	-	
	Exterior SIP Wall	R-23	
	Exterior Wall Rigid Foam Board	-	
	Exterior Wall 2x6 Stucco	-	
	Exterior Wall 2x6 Siding	-	
	Knee Wall	-	
	Floor Over Garage/Exterior	-	
	Sub Floor/Slab	R-28	
HVAC	Minimum SEER2/EER2 Value	14.3 / 11.7	
	Minimum AFUE	7.5	
	Duct Insulation	Ductless	
	Whole House Fan (CFM)	-	
	Fan Wattage (W/CFM)	-	
	Airflow (CFM)	-	
HERS Inspections	Duct Testing Required	-	
	Indoor Air Quality (CFM)	Yes (24)	
	HRV/ERV W/CFM	0.33	
	HRV/ERV SRE	91%	
	HRV/ERV ASRE	97%	
	HRV/ERV Fault Indicator Display	-	
	Kitchen Exhaust	Yes	
	Refrigerant Charge	-	
	SEER2 Verification	-	
	EER2 Verification	-	
	Heat Capacity Verification	Yes	
	Infiltration (CFM)	Yes (153.4)	
	Low Leakage Air Handler	-	
	Insulation Inspection**	Yes	
H₂O	Fuel Type	Heat Pump	
	Uniform Energy Factor (Tank Size)	PROPH50 T2RH375-30	
	Distribution	Standard	
	Windows	<u>U-Value</u>	<u>SHGC</u>
	Operable	0.29	0.23
	Fixed	0.26	0.25

***Builders are strongly encouraged to enforce strict Title 24 compliance with all subcontractor scopes of work. Modifications to Title 24 specifications during construction may result in complications including but not limited to sampling protocol, CF-3R closing delays, state registry errors, and/or loss of rebates plus no CF-3R at final.**

****This document is for communication purposes only. CF-1R compliance certificate(s) will be issued after approval of this document, and after HERS registration has been completed, if needed. Upon receipt of the final CF-1R form(s), please distribute to corresponding subcontractors.**

EXPLANATION OF TITLE-24 DATASHEET

CLIMATE ZONE: California is divided into 16 climate zones each having different weather conditions. Energy efficiency requirements are determined by whether a house is in a hot, cold, or mild climate zone.

PLAN: The square footage of plan and/or plan name used.

ORIENTATION: The direction the house faces expressed in degrees or North, South, East, West (N/S/E/W).

SOURCE ENERGY: How the house compares to the “standard design” in terms of greenhouse gas emissions from its energy sources.

Efficiency EDR: How the house’s overall energy efficiency compares to the “standard design” from the California Energy Commission (CEC). The standard is a house of equal size with features prescribed by the CEC. Anything greater than or equal to 0 complies.

Total EDR: How the house’s overall energy efficiency + **SOLAR** compares to the “standard design.”

% COOLING IMPROVEMENT: How the house compares to the standard design in terms of cooling efficiency.

GLAZING PERCENTAGE: Ratio of windows and glazed doors to the conditioned floor area.

REFLECTANCE/EMITTANCE: Measures of efficiency of roofing material. Reflectance is the ability to reflect solar heat. Emittance is the ability to release absorbed heat. *Aged* reflectance must be used for compliance.

ATTIC FLOOR: R-value of insulation in accessible/open attic area.

VAULT: R-value of insulation in vaulted areas with no attic access.

ATTIC BELOW ROOF DECK: R-value of insulation inside the attic, below the roof deck (roof truss/rafters).

RADIANT BARRIER: Reflective insulation installed at the top chords of the roof truss/rafters.

WALL: R-value of insulation between wall studs.

KNEEWALL: R-value of insulation in walls adjacent to attics.

FLOOR OVER GARAGE/EXTERIOR: R-value of insulation over garage or exterior (cantilevered floor).

SUB FLOOR/SLAB: Lists R-value of insulation in sub floor when one is present. Lists slab when no sub floor is present.

SEER/EER: Minimum cooling equipment efficiency.

(No cooling equipment is designed to cool 100% of time and in all situations. Other relevant design factors such as airflow requirements, outdoor design temperatures, coil sizing, availability of equipment, over sizing safety margin, etc., must also be considered. It is the HVAC contractor's responsibility to consider all factors when selecting the HVAC equipment.)

AFUE: A measure of the minimum furnace efficiency.

HSPF: A measure of heating efficiency of heat pumps.

DUCT INSULATION: Minimum insulation R-value of air ducts, except in conditioned space.

WHOLE HOUSE FAN: The whole house fan pulls air through the house (supplied by open windows) and into the attic. This helps flush hot air out of the house and attic during cool summer nights or mornings.

CFI: (Central Fan Integrated ventilation) The CFI is integrated into the HVAC system to automatically bring in outside air when the outside temperature is lower than the indoor temperature. Cannot be taken alongside the whole house fan.

FAN WATT DRAW: Verification of reduced fan power (Watts/cfm) achieved through improved air distribution system design, including more efficient motors and ducts that have less resistance to airflow.

AIRFLOW: Verification of system airflow rate (CFM) in ducted split and packaged space conditioning systems. If ducts are not designed & installed correctly fan watt & air flow test may have difficulty passing.

DUCT TESTING: If required, an independent HERS Rater has to test the ducts to ensure they leak no more than 5%, and provide verification to the T24 registry and building department.

INDOOR AIR QUALITY (IAQ): If the measured continuous/intermittent airflow is equal to or greater than the value for whole-building ventilation airflow rate (CFM), the mechanical ventilation system complies.

REFRIGERANT CHARGE INSPECTION: The TXV Valve regulates the charge and airflow to increase air conditioner efficiency. If used for compliance, an independent HERS Rater must verify the TXV Valve is installed. RC can't be tested when outdoor temperature is too low and HVAC & rater may have to return at a later date at an extra cost.

PIPE INSULATION: R-4 or greater insulation applied to all 3/4” or larger, non-recirculating hot water mains. This is in addition to the mandatory pipe insulation requirements.

(UNIFORM) ENERGY FACTOR (TANK SIZE): The efficiency rating and the nominal gallon size for the water heaters. The E.F./U.E.F. number is usually listed on a separate tag beside the yellow *EnergyGuide* label. *Uniform* Energy Factor is the new water heater rating standard. Energy Factor was previously used.

QUALITY INSULATION INSTALLATION (QII): An independent HERS Rater must verify the proper installation of insulation. QII inspections commonly fail, causing delays in construction.

WINDOW U-VALUE / U Factor: Minimum U-value of all installed windows. (low values = low thermal escape)

SHGC: Solar Heat Gain Coefficient. A measure of how well your windows stop solar heat from entering your home. A SHGC value of .65 means 65% of the heat is getting into your home and 35% of the heat is being blocked. (low values are good for hot climates) **Fixed/FX** refers to fixed windows. **XO/SH** refers to sliding windows. **SGD** refers to sliding glass door. **FRD/FD** refers to French doors.

CERTIFICATE OF COMPLIANCE - RESIDENTIAL PERFORMANCE COMPLIANCE METHOD

CF1R-PRF-01-E

Project Name: Boxabl

Calculation Date/Time: 2024-07-18T13:25:40-07:00

(Page 1 of 12)

Calculation Description: Studio Casita

Input File Name: BX361C8.ribd22

GENERAL INFORMATION			
01	Project Name	Boxabl	
02	Run Title	Studio Casita	
03	Project Location	Studio Casita	
04	City		05 Standards Version 2022
06	Zip code	90621	07 Software Version CBECC-Res 2022.3.0
08	Climate Zone	8	09 Front Orientation (deg/ Cardinal) All orientations
10	Building Type	Single family	11 Number of Dwelling Units 1
12	Project Scope	Newly Constructed	13 Number of Bedrooms 1
14	Addition Cond. Floor Area (ft ²)	0	15 Number of Stories 1
16	Existing Cond. Floor Area (ft ²)	n/a	Fenestration Average U-factor 0.28
18	Total Cond. Floor Area (ft ²)	361	19 Glazing Percentage (%) 19.94%
20	ADU Bedroom Count	n/a	ADU Conditioned Floor Area n/a
22	Fuel Type	All electric	23 No Dwelling Unit: No

COMPLIANCE RESULTS	
01	Building Complies with Computer Performance
02	This building incorporates features that require field testing and/or verification by a certified HERS rater under the supervision of a CEC-approved HERS provider.
03	This building incorporates one or more Special Features shown below

Registration Number: 424-P010241399A-000-000-00000000-0000

Registration Date/Time: 10/08/2024 15:54

HERS Provider: CHEERS

NOTICE: This document has been generated by California Home Energy Efficiency Rating Services (CHEERS) using information uploaded by third parties not affiliated with or related to CHEERS. Therefore, CHEERS is not responsible for, and cannot guarantee, the accuracy or completeness of the information contained in this document.

CA Building Energy Efficiency Standards - 2022 Residential Compliance

Report Version: 2022.0.000

Report Generated: 2024-07-18 13:26:46

Schema Version: rev 20220901

CERTIFICATE OF COMPLIANCE - RESIDENTIAL PERFORMANCE COMPLIANCE METHOD

CF1R-PRF-01-E

Project Name: Boxabl

Calculation Date/Time: 2024-07-18T13:25:40-07:00

(Page 2 of 12)

Calculation Description: Studio Casita

Input File Name: BX361C8.ribd22

ENERGY DESIGN RATINGS						
	Energy Design Ratings			Compliance Margins		
	Source Energy (EDR1)	Efficiency ¹ EDR (EDR2efficiency)	Total ² EDR (EDR2total)	Source Energy (EDR1)	Efficiency ¹ EDR (EDR2efficiency)	Total ² EDR (EDR2total)
Standard Design	37.8	30.7	52.4			
Proposed Design						
North Facing	36.6	29	51.5	1.2	1.7	0.9
East Facing	36.5	28.8	51.4	1.3	1.9	1
South Facing	36.8	30.5	52.3	1	0.2	0.1
West Facing	36.5	28.9	51.4	1.3	1.8	1
RESULT³: PASS						
¹ Efficiency EDR includes improvements like a better building envelope and more efficient equipment ² Total EDR includes efficiency and demand response measures such as photovoltaic (PV) system and batteries ³ Building complies when source energy, efficiency and total compliance margins are greater than or equal to zero and unmet load hour limits are not exceeded						
<ul style="list-style-type: none"> Standard Design PV Capacity: 0.00 kWdc Proposed PV Capacity Scaling: North (0.00 kWdc) East (0.00 kWdc) South (0.00 kWdc) West (0.00 kWdc) 						

CERTIFICATE OF COMPLIANCE - RESIDENTIAL PERFORMANCE COMPLIANCE METHOD

CF1R-PRF-01-E

Project Name: Boxabl

Calculation Date/Time: 2024-07-18T13:25:40-07:00

(Page 3 of 12)

Calculation Description: Studio Casita

Input File Name: BX361C8.ribd22

ENERGY USE SUMMARY						
Energy Use	Standard Design Source Energy (EDR1) (kBtu/ft ² -yr)	Standard Design TDV Energy (EDR2) (kTDV/ft ² -yr)	Proposed Design Source Energy (EDR1) (kBtu/ft ² -yr)	Proposed Design TDV Energy (EDR2) (kTDV/ft ² -yr)	Compliance Margin (EDR1)	Compliance Margin (EDR2)
Space Heating	0.05	0.32	0.05	0.33	0	-0.01
Space Cooling	3.39	65.8	3.78	70.24	-0.39	-4.44
IAQ Ventilation	0.54	5.63	0.54	5.63	0	0
Water Heating	4.11	44.24	2.73	33.36	1.38	10.88
Self Utilization/Flexibility Credit				0		0
North Facing Efficiency Compliance Total	8.09	115.99	7.1	109.56	0.99	6.43
Space Heating	0.05	0.32	0.04	0.3	0.01	0.02
Space Cooling	3.39	65.8	3.79	69.65	-0.4	-3.85
IAQ Ventilation	0.54	5.63	0.54	5.63	0	0
Water Heating	4.11	44.24	2.72	33.29	1.39	10.95
Self Utilization/Flexibility Credit				0		0
East Facing Efficiency Compliance Total	8.09	115.99	7.09	108.87	1	7.12

Registration Number: 424-P010241399A-000-000-00000000-0000

NOTICE: This document has been generated by California Home Energy Efficiency Rating Services (CHEERS) using information uploaded by third parties not affiliated with or related to CHEERS. Therefore, CHEERS is not responsible for, and cannot guarantee, the accuracy or completeness of the information contained in this document.

CA Building Energy Efficiency Standards - 2022 Residential Compliance

Report Version: 2022.0.000

Report Generated: 2024-07-18 13:26:46

Schema Version: rev 20220901

Registration Date/Time: 10/08/2024 15:54

HERS Provider: CHEERS

CERTIFICATE OF COMPLIANCE - RESIDENTIAL PERFORMANCE COMPLIANCE METHOD

CF1R-PRF-01-E

Project Name: Boxabi

Calculation Date/Time: 2024-07-18T13:25:40-07:00

(Page 4 of 12)

Calculation Description: Studio Casita

Input File Name: BX361C8.ribd22

ENERGY USE SUMMARY

Energy Use	Standard Design Source Energy (EDR1) (kbtu/ft ² -yr)	Standard Design TDV Energy (EDR2) (kTDV/ft ² -yr)	Proposed Design Source Energy (EDR1) (kbtu/ft ² -yr)	Proposed Design TDV Energy (EDR2) (kTDV/ft ² -yr)	Compliance Margin (EDR1)	Compliance Margin (EDR2)
Space Heating	0.05	0.32	0.05	0.37	0	-0.05
Space Cooling	3.39	65.8	3.98	76.01	-0.59	-10.21
IAQ Ventilation	0.54	5.63	0.54	5.63	0	0
Water Heating	4.11	44.24	2.72	33.29	1.39	10.95
Self Utilization/Flexibility Credit				0		0
South Facing Efficiency Compliance Total	8.09	115.99	7.29	115.3	0.8	0.69
Space Heating	0.05	0.32	0.05	0.34	0	-0.02
Space Cooling	3.39	65.8	3.77	69.89	-0.38	-4.09
IAQ Ventilation	0.54	5.63	0.54	5.63	0	0
Water Heating	4.11	44.24	2.72	33.34	1.39	10.9
Self Utilization/Flexibility Credit				0		0
West Facing Efficiency Compliance Total	8.09	115.99	7.08	109.2	1.01	6.79

Registration Number: 424-P010241399A-000-000-00000000-0000

Registration Date/Time: 10/08/2024 15:54

HERS Provider: CHEERS

NOTICE: This document has been generated by California Home Energy Efficiency Rating Services (CHEERS) using information uploaded by third parties not affiliated with or related to CHEERS. Therefore, CHEERS is not responsible for, and cannot guarantee, the accuracy or completeness of the information contained in this document.

CA Building Energy Efficiency Standards - 2022 Residential Compliance

Report Version: 2022.0.000

Report Generated: 2024-07-18 13:26:46

Schema Version: rev 20220901

CERTIFICATE OF COMPLIANCE - RESIDENTIAL PERFORMANCE COMPLIANCE METHOD

CF1R-PRF-01-E

Project Name: Boxabl

Calculation Date/Time: 2024-07-18T13:25:40-07:00

(Page 5 of 12)

Calculation Description: Studio Casita

Input File Name: BX361C8.ribd22

ENERGY USE INTENSITY				
	Standard Design (kBtu/ft ² - yr)	Proposed Design (kBtu/ft ² - yr)	Compliance Margin (kBtu/ft ² - yr)	Margin Percentage
North Facing				
Gross EUJ ¹	42.56	41.81	0.75	1.76
Net EUJ ²	42.56	41.81	0.75	1.76
East Facing				
Gross EUJ ¹	42.56	41.91	0.65	1.53
Net EUJ ²	42.56	41.91	0.65	1.53
South Facing				
Gross EUJ ¹	42.56	42.31	0.25	0.59
Net EUJ ²	42.56	42.31	0.25	0.59
West Facing				
Gross EUJ ¹	42.56	41.56	1	2.35
Net EUJ ²	42.56	41.56	1	2.35
Notes 1. Gross EUJ is Energy Use Total (not including PV) / Total Building Area. 2. Net EUJ is Energy Use Total (including PV) / Total Building Area.				

CERTIFICATE OF COMPLIANCE - RESIDENTIAL PERFORMANCE COMPLIANCE METHOD

CF1R-PRF-01-E

Project Name: Boxabl

Calculation Date/Time: 2024-07-18T13:25:40-07:00

(Page 6 of 12)

Calculation Description: Studio Casita

Input File Name: BX361C8.ribd22

REQUIRED PV SYSTEMS

01	02	03	04	05	06	07	08	09	10	11	12
DC System Size (kWdc)	Exception	Module Type	Array Type	Power Electronics	CFI	Azimuth (deg)	Tilt Input	Array Angle (deg)	Tilt: (x in 12)	Inverter Eff. (%)	Annual Solar Access (%)
0		Standard (14-17%)	Fixed	none	true	n/a	n/a	n/a	n/a	n/a	

REQUIRED SPECIAL FEATURES

The following are features that must be installed as condition for meeting the modeled energy performance for this computer analysis.

- PV exception 2: No PV required when minimum PV size (Section 150.1(c)14) < 1.8 kWdc (0 kW)
- Indoor air quality, balanced fan
- IAQ Ventilation System: as low as 0.33 W/CFM
- IAQ Ventilation System Heat Recovery: minimum 91 SRE and 97 ASRE
- Cool roof
- Ceiling has high level of insulation
- Floor has high level of insulation
- Insulation above roof deck
- Structurally insulated panel (SIP) assembly
- Compact distribution system basic credit
- Northwest Energy Efficiency Alliance (NEEA) rated heat pump water heater; specific brand/model, or equivalent, must be installed

HERS FEATURE SUMMARY

The following is a summary of the features that must be field-verified by a certified HERS Rater as a condition for meeting the modeled energy performance for this computer analysis. Additional detail is provided in the building tables below. Registered CF2Rs and CF3Rs are required to be completed in the HERS Registry

- Quality insulation installation (QII)
- Building air leakage/reduced infiltration
- Indoor air quality ventilation
- Kitchen range hood
- Verified heat pump rated heating capacity

Registration Number: 424-P010241399A-000-000-00000000-0000

Registration Date/Time: 10/08/2024 15:54

HERS Provider: CHEERS

NOTICE: This document has been generated by California Home Energy Efficiency Rating Services (CHEERS) using information uploaded by third parties not affiliated with or related to CHEERS. Therefore, CHEERS is not responsible for, and cannot guarantee, the accuracy or completeness of the information contained in this document.

CA Building Energy Efficiency Standards - 2022 Residential Compliance

Report Version: 2022.0.000

Report Generated: 2024-07-18 13:26:46

Schema Version: rev 20220901

CERTIFICATE OF COMPLIANCE - RESIDENTIAL PERFORMANCE COMPLIANCE METHOD

CF1R-PRF-01-E

Project Name: Boxabl

Calculation Date/Time: 2024-07-18T13:25:40-07:00

(Page 7 of 12)

Calculation Description: Studio Casita

Input File Name: BX361C8.ribd22

BUILDING - FEATURES INFORMATION						
01	02	03	04	05	06	07
Project Name	Conditioned Floor Area (ft ²)	Number of Dwelling Units	Number of Bedrooms	Number of Zones	Number of Ventilation Cooling Systems	Number of Water Heating Systems
Boxabl	361	1	1	1	0	1

ZONE INFORMATION						
01	02	03	04	05	06	07
Zone Name	Zone Type	HVAC System Name	Zone Floor Area (ft ²)	Avg. Ceiling Height	Water Heating System 1	Status
Conditioned	Conditioned	HVAC	361	10.2	DHW	New

OPAQUE SURFACES							
01	02	03	04	05	06	07	08
Name	Zone	Construction	Azimuth	Orientation	Gross Area (ft ²)	Window and Door Area (ft ²)	Tilt (deg)
Front Wall	Conditioned	R-23 Wall	0	Front	193.8	42	90
Left Wall	Conditioned	R-23 Wall	90	Left	193.8	36	90
Back Wall	Conditioned	R-23 Wall	180	Back	193.8	24	90
Right Wall	Conditioned	R-23 Wall	270	Right	193.8	18	90
Ceiling	Conditioned	R-41 Attic Roof	n/a	n/a	361	n/a	n/a
Subfloor	Conditioned	R-28 Subfloor	n/a	n/a	361	n/a	n/a

ATTIC							
01	02	03	04	05	06	07	08
Name	Construction	Type	Roof Rise (x in 12)	Roof Reflectance	Roof Emittance	Radiant Barrier	Cool Roof
Attic	Built Up HPA	Ventilated	5	0.2	0.85	No	Yes

Registration Number: 424-P010241399A-000-000-00000000-00000

NOTICE: This document has been generated by California Home Energy Efficiency Rating Services (CHEERS) using information uploaded by third parties not affiliated with or related to CHEERS. Therefore, CHEERS is not responsible for, and cannot guarantee, the accuracy or completeness of the information contained in this document.

Registration Date/Time: 10/08/2024 15:54

HERS Provider: CHEERS

CA Building Energy Efficiency Standards - 2022 Residential Compliance

Report Version: 2022.0.000

Report Generated: 2024-07-18 13:26:46

Schema Version: rev 20220901

CERTIFICATE OF COMPLIANCE - RESIDENTIAL PERFORMANCE COMPLIANCE METHOD

CF1R-PRF-01-E

Project Name: Boxabl

Calculation Date/Time: 2024-07-18T13:25:40-07:00

(Page 8 of 12)

Calculation Description: Studio Casita

Input File Name: BX361C8.ribd22

FENESTRATION / GLAZING													
01	02	03	04	05	06	07	08	09	10	11	12	13	14
Name	Type	Surface	Orientation	Azimuth	Width (ft)	Height (ft)	Mult.	Area (ft ²)	U-factor	U-factor Source	SHGC	SHGC Source	Exterior Shading
3060 Oper	Window	Front Wall	Front	0	3	6	1	18	0.29	NFRC	0.23	NFRC	Bug Screen
3060 Oper 2	Window	Left Wall	Left	90	3	6	1	18	0.29	NFRC	0.23	NFRC	Bug Screen
3060 Oper 3	Window	Left Wall	Left	90	3	6	1	18	0.29	NFRC	0.23	NFRC	Bug Screen
3020 FX	Window	Right Wall	Right	270	3	2	1	6	0.26	NFRC	0.25	NFRC	Bug Screen
3040 FX	Window	Right Wall	Right	270	3	4	1	12	0.26	NFRC	0.25	NFRC	Bug Screen

OPAQUE DOORS			
01	02	03	04
Name	Side of Building	Area (ft ²)	U-factor
Entry	Front Wall	24	0.17
Back Door	Back Wall	24	0.17

OPAQUE SURFACE CONSTRUCTIONS							
01	02	03	04	05	06	07	08
Construction Name	Surface Type	Construction Type	Framing	Total Cavity R-value	Interior / Exterior Continuous R-value	U-factor	Assembly Layers
R-23 Wall	Exterior Walls	SIPS Wall	4.5in. OSB @ 48 in. O. C.	R-23	None / None	0.049	Inside Finish: Gypsum Board Panel Rated R (@ 75 F): R-23 / 4.5in. OSB Exterior Finish: All Other Siding

Registration Number: 424-P010241399A-000-000-00000000-0000

Registration Date/Time: 10/08/2024 15:54

HERS Provider: CHEERS

NOTICE: This document has been generated by California Home Energy Efficiency Rating Services (CHEERS) using information uploaded by third parties not affiliated with or related to CHEERS. Therefore, CHEERS is not responsible for, and cannot guarantee, the accuracy or completeness of the information contained in this document.

CA Building Energy Efficiency Standards - 2022 Residential Compliance

Report Version: 2022.0.000

Report Generated: 2024-07-18 13:26:46

Schema Version: rev 20220901

CERTIFICATE OF COMPLIANCE - RESIDENTIAL PERFORMANCE COMPLIANCE METHOD

CF1R-PRF-01-E

Project Name: Boxabl

Calculation Date/Time: 2024-07-18T13:25:40-07:00

(Page 9 of 12)

Calculation Description: Studio Casita

Input File Name: BX361C8.ribd22

OPAQUE SURFACE CONSTRUCTIONS							
01	02	03	04	05	06	07	08
Construction Name	Surface Type	Construction Type	Framing	Total Cavity R-value	Interior / Exterior Continuous R-value	U-factor	Assembly Layers
Built Up HPA	Attic Roofs	Built-up Roof	2x4 Top Chord of Roof Truss @ 24 in. O. C.	R-0	None / 10	0.085	Roofing: 5 PSF (Normal Gravel) Above Deck Insulation: R-10 Sheathing Roof Deck: Wood Siding/sheathing/decking Cavity / Frame: no insul. / 2x4 Top Chrd
R-28 Subfloor	Floors Over Crawlspace	SIPS Floor	6.5in. Pnl Other	R-28	None / None	0.035	Floor Surface: Carpeted Wood Siding/sheathing/decking Cavity / Frame: R-28 / 6.5in. Pnl Exterior Finish: Wood Siding/sheathing/decking
R-41 Attic Roof	Ceilings (below attic)	Wood Framed Ceiling	2x4 @ 24 in. O. C.	R-41	None / None	0.024	Over Ceiling Joists: R-31.9 insul. Cavity / Frame: R-9.1 / 2x4 Inside Finish: Gypsum Board

BUILDING ENVELOPE - HERS VERIFICATION			
01	02	03	04
Quality Insulation Installation (QII)	High R-value Spray Foam Insulation	Building Envelope Air Leakage	CFM50
Required	Not Required	Required	153.4
			2.5

WATER HEATING SYSTEMS							
01	02	03	04	05	06	07	08
Name	System Type	Distribution Type	Water Heater Name	Number of Units	Solar Heating System	Compact Distribution	HERS Verification
DHW	Domestic Hot Water (DHW)	Standard	Water Heater	1	n/a	Basic	n/a
							Water Heater (1)

Registration Number: 424-P010241399A-000-000-00000000-0000

Registration Date/Time: 10/08/2024 15:54

HERS Provider: CHEERS

NOTICE: This document has been generated by California Home Energy Efficiency Rating Services (CHEERS) using information uploaded by third parties not affiliated with or related to CHEERS. Therefore, CHEERS is not responsible for, and cannot guarantee, the accuracy or completeness of the information contained in this document.

CA Building Energy Efficiency Standards - 2022 Residential Compliance

Report Version: 2022.0.000

Report Generated: 2024-07-18 13:26:46

Schema Version: rev 20220901

CERTIFICATE OF COMPLIANCE - RESIDENTIAL PERFORMANCE COMPLIANCE METHOD

CF1R-PRF-01-E

Project Name: Boxabl

Calculation Date/Time: 2024-07-18T13:25:40-07:00

(Page 10 of 12)

Calculation Description: Studio Casita

Input File Name: BX361C8.ribd22

WATER HEATERS - NEEA HEAT PUMP							
01	02	03	04	05	06	07	08
Name	# of Units	Tank Vol. (gal)	NEEA Heat Pump Brand	NEEA Heat Pump Model	Tank Location	Duct Inlet Air Source	Duct Outlet Air Source
Water Heater	1	50	Rheem	PROPH50 T2 RH37530 (50 gal, JA13)	TankZone	Outside	Outside

WATER HEATING - COMPACT DISTRIBUTION						
01	02	03	04	05	06	07
Dwelling Unit type	Water Heating System Name	Master Bath distance of furthest fixture to Water Heater (ft)	Kitchen distance of furthest fixture to Water Heater (ft)	Furthest Third furthest fixture to Water Heater (ft)	Compactness Factor	HERS Verification
Dwelling	DHW	7.6	5.5	n/a	0.7	n/a

WATER HEATING - HERS VERIFICATION						
01	02	03	04	05	06	07
Name	Pipe Insulation	Parallel Piping	Compact Distribution	Compact Distribution Type	Recirculation Control	Shower Drain Water Heat Recovery
DHW - 1/1	Not Required	Not Required	Not Required	Basic	Not Required	Not Required

SPACE CONDITIONING SYSTEMS								
01	02	03	04	05	06	07	08	09
Name	System Type	Heating Unit Name	Heating Equipment Count	Cooling Unit Name	Cooling Equipment Count	Fan Name	Distribution Name	Required Thermostat Type
HVAC	Heat pump heating cooling	Heat Pump	1	Heat Pump	1	n/a	n/a	Setback

Registration Number: 424-P010241399A-000-000-00000000-0000

Registration Date/Time: 10/08/2024 15:54

HERS Provider: CHEERS

NOTICE: This document has been generated by California Home Energy Efficiency Rating Services (CHEERS) using information uploaded by third parties not affiliated with or related to CHEERS. Therefore, CHEERS is not responsible for, and cannot guarantee, the accuracy or completeness of the information contained in this document.

CA Building Energy Efficiency Standards - 2022 Residential Compliance

Report Version: 2022.0.000

Report Generated: 2024-07-18 13:26:46

Schema Version: rev 20220901

CERTIFICATE OF COMPLIANCE - RESIDENTIAL PERFORMANCE COMPLIANCE METHOD

CF1R-PRF-01-E

Project Name: Boxabl

Calculation Date/Time: 2024-07-18T13:25:40-07:00

(Page 11 of 12)

Calculation Description: Studio Casita

Input File Name: BX361C8.ribd22

HVAC - HEAT PUMPS													
01	02	03	04	05	Heating			Cooling			11	12	13
					Heating Efficiency Type	HSPF/HS PF2/COP	Cap 47	Cap 17	Cooling Efficiency Type	SEER/SE ER2			
Name	System Type	Number of Units											HERS Verification
Heat Pump	Ductless MiniSplit HP	1	HSPE2	7.5	12000	6840	EER2SEER2	EER2SEER2	14.3	11.7	Not Zonal	Single Speed	Heat Pump-hers-htpump

HVAC HEAT PUMPS - HERS VERIFICATION									
01	02	03	04	05	06	07	08	09	
Name	Verified Airflow	Airflow Target	Verified EER/EER2	Verified SEER/SEER2	Verified Refrigerant Charge	Verified HSPF/HSPF2	Verified Heating Cap 47	Verified Heating Cap 17	
Heat Pump-hers-htpump	Not Required	0	Not Required	Not Required	No	No	Yes	Yes	Yes

INDOOR AIR QUALITY (IAQ) FANS									
01	02	03	04	05	06	07	08	09	
Dwelling Unit	Airflow (CFM)	Fan Efficacy (W/CFM)	IAQ Fan Type	Includes Heat/Energy Recovery?	IAQ Recovery Effectiveness - SRE/ASRE	Includes Fault Indicator Display?	HERS Verification	Status	
SFam IAQVentRpt 1-1	24	0.33	Balanced	Yes	91 / 97	No	Yes		

CERTIFICATE OF COMPLIANCE - RESIDENTIAL PERFORMANCE COMPLIANCE METHOD

CF1R-PRF-01-E



Project Name: Boxabl

Calculation Date/Time: 2024-07-18T13:25:40-07:00

(Page 12 of 12)

Calculation Description: Studio Casita

Input File Name: BX361C8.ribd22

DOCUMENTATION AUTHOR'S DECLARATION STATEMENT	
1. I certify that this Certificate of Compliance documentation is accurate and complete.	
Documentation Author Name: James Hernandez	Documentation Author Signature: 
Company: Builder Services Network	Signature Date: 10/08/2024
Address: 2937 Veneman Avenue	CEA/ HERS Certification Identification (if applicable): R22-18-40006
City/State/Zip: Modesto, CA 95356	Phone: 209-538-2879
RESPONSIBLE PERSON'S DECLARATION STATEMENT	
I certify the following under penalty of perjury, under the laws of the State of California:	
<ol style="list-style-type: none">I am eligible under Division 3 of the Business and Professions Code to accept responsibility for the building design identified on this Certificate of Compliance.I certify that the energy features and performance specifications identified on this Certificate of Compliance conform to the requirements of Title 24, Part 1 and Part 6 of the California Code of Regulations.The building design features or system design features identified on this Certificate of Compliance are consistent with the information provided on other applicable compliance documents, worksheets, calculations, plans and specifications submitted to the enforcement agency for approval with this building permit application.	
Responsible Designer Name: Kyle Denman	Responsible Designer Signature: 
Company: Boxabl	Date Signed: 10/08/2024
Address: 5345 E N Belt Rd	License:
City/State/Zip: Las Vegas, NV 89115	Phone: 7027478250



Digitally signed by California Home Energy Efficiency Rating Services (CHEERS). This digital signature is provided in order to secure the content of this registered document, and in no way implies Registration Provider responsibility for the accuracy of the information.

Registration Number: 424-P010241399A-000-000-00000000-0000

Registration Date/Time: 10/08/2024 15:54

HERS Provider: CHEERS

NOTICE: This document has been generated by California Home Energy Efficiency Rating Services (CHEERS) using information uploaded by third parties not affiliated with or related to CHEERS. Therefore, CHEERS is not responsible for, and cannot guarantee, the accuracy or completeness of the information contained in this document.

CA Building Energy Efficiency Standards - 2022 Residential Compliance

Report Version: 2022.0.000

Report Generated: 2024-07-18 13:26:46

Schema Version: rev 20220901

These Values were used to calculate CBECC RES 2022 Compliance using the Residential Performance Compliance Method

WALL ASSEMBLY

OUTSIDE AIR FILM: 0.25

5.75" EPS WALL PANEL: 22.54 (ASSUMES R VALUE OF 3.92/INCH) VARIES ANYWHERE FROM 3.5 TO 4.0

1/4" MGO BOARD: 0

INSIDE AIR FILM: 0.68

• TOTAL FOR WALL ASSEMBLY: R= 23.47 U= 0.0426

FLOOR ASSEMBLY

OUTSIDE AIR FILM: 0.92

6.75" EPS WALL PANEL: 26.46 (ASSUMES R VALUE OF 3.92/INCH) VARIES ANYWHERE FROM 3.5 TO 4.0

1/4" MGO BOARD: 0

INSIDE AIR FILM: 0.92

• TOTAL FOR FLOOR ASSEMBLY: R= 28.3U= 0.0354

ROOF ASSEMBLY

OUTSIDE AIR FILM: 0.61

6.75" EPS WALL PANEL: 26.46 (ASSUMES R VALUE OF 3.92/INCH) VARIES ANYWHERE FROM 3.5 TO 4.0

1/4" MGO BOARD: 0

INSIDE AIR FILM: 0.61

• TOTAL FOR ROOF ASSEMBLY: R= 27.68 U= 0.0362

NOTES

- Climate Zones 4, 13, 14 & 16 add R-13 below roof deck insulation
- R values noted above (R3.92/IN) are referenced in ICC Evaluation Report ESR-1962 for expanded polystyrene insulation. This insulation is listed as the insulation used in the ICC ES Evaluation Report ESR-4725 for Boxabl Structural Insulation Panels
- SIP Panel Assembly R-Values were calculated using listed insulation values & air barrier. Internal & external sheathing was not factored into total panel performance.



To: Atlas Molded Products
8700 Turnpike Drive, Suite 400
Westminster, CO 80031

Date: August 25, 2022

Title: Compressive Strength, Flexural Strength, Density, Water Absorption and Thermal Transmission Tests

Project No: AMP-081522-1

Introduction:

This report presents the results of compressive strength, flexural strength, density, water absorption and thermal transmission on one sample set identified as AMP Block Code: 101-00 BlockTrak ID: S47791B. The sample set was submitted by Todd Bergstrom of Atlas Molded Products – Westminster, CO on August 15, 2022. Samples were cut and prepared prior to receipt August 15, 2022. The samples were in good condition upon receipt. Testing and analysis were completed on August 24, 2022.

The scope of work was limited to conducting compressive strength, flexural strength, density, water absorption and thermal transmission tests in accordance with ASTM C578-19 and reporting the results.

Test Methods:

Compression testing was conducted in accordance with ASTM D1621-16, "Standard Test Method for Compressive Properties of Rigid Cellular Plastics." Testing was conducted using an Instron universal testing machine on nominal 2 in. x 2 in. x 2 in. samples at a rate of loading of 0.2 inches per minute.

Equipment: Universal Testing Machine, ID UTM 2, calibrated 11/16/21.
Equipment: Force Transducer, ID Load Cell 2, calibrated 11/16/21.
Equipment: Deflectometer, ID Deflectometer 2, calibrated 11/16/21.

Flexural testing was conducted in accordance with ASTM C203-05a, "Standard Test Methods for Breaking Load and Flexural Properties of Block-Type Thermal Insulation," Method I, Procedure B. Testing was conducted using a universal testing machine on nominal 1 in. x 4 in. x 12 in. samples at a rate of loading of 1.67 inches per minute at a span of 10 in. Support span-to-depth ratio was 10, support span-to-width ratio was 2.5, and width-to-depth ratio was 4.0. The radius of supports and loading fixture was 1.25 in.

Equipment: Universal Testing Machine, ID UTM 2, calibrated 11/16/21.
Equipment: Force Transducer, ID Load Cell 2, calibrated 11/16/21.

Water absorption testing was conducted in accordance with ASTM C272-18, "Standard Test Method for Water Absorption of Core Materials for Sandwich Constructions" Testing was conducted on nominal 12 in. x 12 in. x 1 in. samples using Procedure A and immersing the samples 24 hours.

Equipment: 6" Caliper – 20 mm foot, ID Caliper 1, calibrated 5/23/22.
Equipment: 16" Digital Calipers, ID Caliper 4, calibrated 5/23/22.
Equipment: Digital balance, ID Scale 1, calibrated 5/23/22.
Equipment: Step Block, ID ASTM C1763, calibrated 6/19/19.

Information and statements in this report are derived from the material and information furnished by the client and exclude any expressed or implied warranty as to its fitness of the material tested for any particular purpose or use.

ATZ**LABORATORY**17645 Juniper Path, Ste. 260
Lakeville, MN 55044

Thermal transmission testing was conducted in accordance with ASTM C518-17, "Standard Test Methods for Steady-State Thermal Transmission Properties by Means of the Heat Flow Meter Apparatus". Testing was conducted using a Netzsch heat flow meter on nominal 1 in. x 12 in. x 12 in. samples at a mean temperature of 75°F and a temperature differential of 40°F.

Equipment: Heat Flow Meter, ID HFM 1, calibrated 5/23/22.
Reference Material: NIST SRM 1450d, high density fiberglass.
The measurement uncertainty is estimated at 2.6%.

Density testing was conducted in accordance with ASTM D1622-20, "Test Method for Apparent Density of Rigid Cellular Plastics."

Equipment: 6" Caliper – 20 mm foot, ID Caliper 1, calibrated 5/23/22.
Equipment: 16" Digital Calipers, ID Caliper 4, calibrated 5/23/22.
Equipment: Digital balance, ID Scale 1, calibrated 5/23/22.

Compression, Flexural, and R-value samples were tested after conditioning for 40 hours at 73°F and 50% RH. Laboratory conditions were 72°F and 48%RH at time of compressive testing, 73°F and 47%RH at time of flexural testing, 73°F and 48%RH at time of water absorption testing, and 74°F and 49%RH at time of R-value testing.

Equipment: Temperature/Humidity Sensor, ID WiFi Sensor #5, calibrated 2/24/22.
Equipment: Temperature/Humidity Sensor, ID WiFi Sensor #6, calibrated 2/24/22.

Results:

Test data is presented on pages 3-6 of this report.

Prepared By:

Cristy MillerDigitally signed by Cristy
Miller
Date: 2022.08.25
10:49:49 -05'00'

Reviewed By:

**Todd
Bergstrom, PhD**Digitally signed by Todd
Bergstrom, PhD
Date: 2022.08.25
10:56:05 -05'00'

Information and statements in this report are derived from the material and information furnished by the client and exclude any expressed or implied warranty as to its fitness of the material tested for any particular purpose or use.



**COMPRESSIVE STRENGTH (ASTM D1621-16)
AND DENSITY (ASTM D1622-20)**

Specimen	Width, in.	Depth, in.	Height, in.	Weight, g	Density, pcf	Comp. Strength @ 10% strain, psi
1	1.958	2.008	1.955	2.26	1.12	14.5
2	2.025	1.993	1.979	2.17	1.03	13.9
3	2.031	1.990	1.980	2.18	1.03	13.9
4	1.958	2.008	1.962	2.27	1.12	15.6
5	1.964	2.008	1.960	2.27	1.12	14.6
Average					1.08	14.5
Std. Dev					0.05	0.7

Information and statements in this report are derived from the material and information furnished by the client and exclude any expressed or implied warranty as to its fitness of the material tested for any particular purpose or use.



**FLEXURAL STRENGTH (ASTM C203-05a)
AND DENSITY (ASTM D1622-20)**

Specimen	Width, in.	Length, in.	Thickness, in.	Weight, g	Density, pcf	Peak Load, Lbs.	Flexural Strength, psi
1	3.970	11.994	0.978	12.57	1.03	8.1	32.0
2	3.970	11.998	0.973	12.53	1.03	7.9	31.6
3	3.974	11.999	0.980	12.58	1.02	8.2	32.2
4	3.991	11.975	0.984	12.43	1.00	7.6	29.5
5	3.960	11.978	0.981	12.58	1.03	8.0	31.5
Average					1.02	8.0	31.4
Std. Dev					0.01	0.2	1.1

Information and statements in this report are derived from the material and information furnished by the client and exclude any expressed or implied warranty as to its fitness of the material tested for any particular purpose or use.



**DENSITY (ASTM D1622-20) AND
WATER ABSORPTION (ASTM C272-18)**

Specimen	Width, in.	Depth, in.	Height, in.	Initial Weight, g	Density, pcf	Final Weight, g	Water Absorption, Weight %	Water Absorption, Vol. %
1	11.902	11.991	0.988	37.87	1.02	87.82	131.9%	2.2%
2	11.911	11.964	0.996	38.62	1.03	89.68	132.2%	2.2%
3	11.918	11.972	0.994	38.56	1.03	85.52	121.8%	2.0%
Average					1.03		128.6%	2.1%
Std. Dev					0.01		5.9%	0.1%

Information and statements in this report are derived from the material and information furnished by the client and exclude any expressed or implied warranty as to its fitness of the material tested for any particular purpose or use.



17645 Juniper Path, Ste. 260
Lakeville, MN 55044

Thermal Transmission Properties (ASTM C518-17)

Sample Properties				
Property	Units	1	2	3
Thickness	inches	0.987	0.982	0.985
	cm	2.51	2.49	2.50
Length	inches	11.93	12.02	12.00
	cm	30.30	30.52	30.48
Width	inches	12.01	11.93	11.92
	cm	30.51	30.30	30.28
Weight	Prior to conditioning, g	38.13	37.94	38.08
	After conditioning, g	38.03	37.84	37.98
	% change	-0.3%	-0.3%	-0.3%
	After testing, g	38.03	37.83	37.97
	% change	0.0%	0.0%	0.0%
Density	lbs/ft ³	1.02	1.02	1.03
	kg/m ³	16.4	16.4	16.4

Test Conditions				
Mean Temperature	°F	74.7	74.7	74.7
	°C	23.7	23.7	23.7
Temperature Range	°F	39.7	39.7	39.7
	°C	22.0	22.0	22.0
Test Time	hr:min:sec	0:22:20	0:24:03	0:24:05

Results				
Thermal Conductance	Btu/(hr*ft ² *°F)	0.259	0.260	0.258
	W/m ² *°K	1.47	1.47	1.47
Thermal Resistance	hr*ft ² *°F/Btu	3.86	3.85	3.87
	m ² *°K/W	0.679	0.679	0.682
Thermal Conductivity	Btu*in/(hr*ft ² *°F)	0.256	0.255	0.254
	W/m*°K	0.037	0.037	0.037
Thermal Resistivity	hr*ft ² *°F/(Btu*in)	3.91	3.92	3.93
	m*°K/W	27.10	27.21	27.27

Average Density	1.02	lbs/ft³
Average Thermal Resistance @ 1.0 in.	3.92	hr*ft²*°F/Btu

Information and statements in this report are derived from the material and information furnished by the client and exclude any expressed or implied warranty as to its fitness of the material tested for any particular purpose or use.



ICC-ES Evaluation Report

ESR-4725

Reissued May 2024

This report also contains:

- CBC Supplement

Subject to renewal May 2025

- LABC Supplement

ICC-ES Evaluation Reports are not to be construed as representing aesthetics or any other attributes not specifically addressed, nor are they to be construed as an endorsement of the subject of the report or a recommendation for its use. There is no warranty by ICC Evaluation Service, LLC, express or implied, as to any finding or other matter in this report, or as to any product covered by the report.

Copyright © 2024 ICC Evaluation Service, LLC. All rights reserved.

<p>DIVISION: 06 00 00— WOOD, PLASTICS AND COMPOSITES</p> <p>Section: 06 12 00— Structural Panels</p>	<p>REPORT HOLDER: BOXABL</p>	<p>EVALUATION SUBJECT: BOXABL STRUCTURAL INSULATED PANELS (SIPs)</p>	
---	--	--	---

1.0 EVALUATION SCOPE

Compliance with the following codes:

- 2021 and 2018 [International Building Code® \(IBC\)](#)
- 2021 and 2018 [International Residential Code® \(IRC\)](#)

For evaluation for compliance with codes adopted by the [Los Angeles Department of Building and Safety \(LADBS\)](#) see [ESR-4725 LABC and LARC Supplement](#).

Properties evaluated:

- Structural
- Thermal Barrier
- Weather Resistive Barrier
- Seismic Performance

2.0 USES

2.1 General.

Boxabl Structural Insulated Panels (SIPs) are used as load-bearing wall, floor, and roof panels capable of resisting transverse, axial and in-plane shear loads. Boxabl SIPs are only used in Boxabl Casitas, factory-built structures using the proprietary Boxabl connection system.

2.2 Construction Types

The Structural Insulated Panels shall be considered combustible building elements when determining the construction type in accordance with IBC Chapter 6.

2.3 Fire Resistive Assemblies

Structural Insulated Panels have not been evaluated in fire-resistance-rated construction.

3.0 DESCRIPTION

3.1 General:

Boxabl Structural Insulated Panels are factory-laminated sandwich panels consisting of one steel facing and one magnesium oxide panel facing with an expanded polystyrene (EPS) foam core. The Structural Insulated Panels are available in 6 inch (152.4 mm) thick wall panels and 7.5 inch (190.5 mm) thick roof and floor panels.



3.2 Material:

3.2.1 Expanded Polystyrene: The EPS foam plastic core complies with ASTM C578, Type I. The EPS foam plastic has a

flame-spread index not exceeding 25 and a smoke-developed index not exceeding 450 when tested in accordance with ASTM E84.

3.2.2 Exterior Facing: The exterior facing material has a minimum yield strength of 50 ksi (345 MPa) 24 ga. (0.0289 inch or 0.73 mm) Steel with a G60 galvanization coating and a primer paint. The steel facing is 57 inches (1447.8 mm) wide and the full height of the structural insulated panel. The edges of the facings are hemmed and bent with a design to allow interlocking between each panel as shown in [Figure 1](#). The ends of the facings are hemmed and bent to allow the metal to insert into a slot in the end caps of the wall and roof panels as shown in [Figure 2](#).

3.2.3 Interior Facing: The interior facing material is 0.236-inch (6 mm) thick magnesium oxide (MgO) board complying with ICC-ES Acceptance Criteria for Fiber-Reinforced Magnesium-Oxide-Based Sheets (AC386). The boards are 48 inches (1219.2 mm) wide and the full height of the structural insulated panel.

3.2.4 Adhesive: The adhesives comply with Type II, Class 2, performance requirements set forth in the ICC-ES Acceptance Criteria for Sandwich Panel Adhesives (AC05).

3.2.5 Panel Seams: Boxabl SIP walls, floors and roofs have seams in the facings, and core material. Seams between EPS core, steel facing and MgO facings are staggered such that there are no continuous joints from outside facing to inside facing (see [Figure 3](#)). Metal facings are hemmed together with folded edges which fit inside each other as shown in [Figure 1](#). MgO seams have an additional MgO backer connecting the two panels.

3.2.6 Panel Joints: Wall to wall, wall to roof, wall to floor connections are made through PVC connector plates designed to interlock and seal with each other. The joints are detailed in [Figure 6](#).

3.2.6.1 Edge and End Plates: Boxabl SIP wall and roof ends and edges use PVC profiles attached to 2.0E LVL members embedded in the panels to connect and seal between panels. Additional PVC profiles are used for connections at wall-to-wall corners and wall-to-roof or floor corners ([Figure 4](#)).

3.2.6.2 Hinges: Boxabl Casita's use hinged connections at wall-to-wall panel connection and roof-to-roof panel connections to accommodate the Casita folding design.

3.2.6.3 EPDM Seals: Boxabl uses EPDM seals between the PVC profiles as part of the system of sealing the joint between walls, roofs and floors. (See [Figure 5](#))

4.0 DESIGN AND INSTALLATION

4.1 Design:

Boxabl Structural Insulated Panels are manufactured specifically for use in Boxabl Casita factory-built structures. Panels are interconnected using proprietary hinged connections and interlocking PVC profiles and seals. Boxabl wall, roof, and floor SIPs are limited to the allowable loads and loading conditions indicated in [Tables 1](#) through [4](#) of this report.

The seismic-force-resisting system of structures consisting of the panels as shear walls, in whole or in part, must be designed and detailed in accordance with the IBC.

Where loading conditions result in the panels resisting combined stresses, the sum of the ratios of actual load over allowable load must be less than 1.0.

Use of roof and floor panels to resist lateral forces as diaphragms is outside scope of this report.

4.2 Installation: Boxabl SIPs must be installed in accordance with the manufacturer's published installation instructions, this evaluation report and the plans and specifications approved by the code official. A copy of the instructions must be available at all times on the jobsite during installation.

4.3 Panel Connections: Boxabl panel to panel connections are accomplished through mating PVC connectors described in Section 3.2.6.1 and shown in [Figures 4](#) through [6](#). Panel to panel connections are secured using 10-inch-long (254 mm) SIPLD-1000 Fasteners spaced a minimum of 10 inches (254 mm) on center fastened into end and edge cap plates. Capacity of the panel to panel connections must be designed by a registered design professional.



4.4 Cutting and Notching: No field cutting or routing of the panels shall be permitted except as shown on approved construction documents.

4.5 Heat-Producing Fixtures: Heat producing fixtures shall not be installed in the panels unless protected by a method approved by the code official or documented in test reports.

4.6 Plumbing Installation Restrictions: Plumbing and waste lines may extend at right angles through the wall panels but are not permitted vertically within the core. Lines shall not interrupt splines or panel plates unless approved by a registered design professional.

4.7 Voids and Holes: Voids may be provided in the panel core during fabrication at predetermined locations only. Voids parallel to the panel span shall be limited to a single 1-1/2 inch (38.1 mm) maximum diameter hole. Such voids shall be spaced a minimum of 4 feet (1219 mm) on-center measured perpendicular to the panel span. Voids perpendicular to the panel span shall be limited to a single 1-1/2 inch (38.1 mm) maximum diameter hole placed not closer than 15-1/4 inches (387.4 mm) from the support.

4.8 In-Plane Shear Design: Shear walls utilizing Boxabl SIPs shall be sized to resist all code required wind and seismic loads without exceeding the allowable loads provided in [Table 3](#) or [Table 4](#), as applicable. Shear walls are constructed in one piece with top and bottom cap plates. Shear wall chords, hold-downs and connections to transfer shear forces between the wall and surrounding structure shall be designed in accordance with accepted engineering practice.

4.8.1 Special Inspections: SIP shear walls installed in buildings in IBC Seismic Design Categories C, D, E and F; Seismic Design Categories C, D₀, D₁, D₂ and E for townhouses under the IRC; or Seismic Design Categories D₀, D₁, D₂ and E for detached one- and two-family dwellings under the IRC, periodic inspections of the fastening and anchoring of the shear wall assembly within the seismic-force-resisting system must be provided. Inspection must include connections of the assemblies to drag struts and hold-downs, in accordance with 2021 IBC Section 1705.13 and 2018 IBC Section 1705.12

4.8.2 Seismic Design Categories A, B, and C: Use of the shear wall configurations in [Table 3](#) is limited to structures in Seismic Design Categories A, B, and C, where SIPs are used to resist seismic forces the following factors shall be used for design: Response Modification Coefficient $R = 2.0$; System Overstrength Factor, $\Omega_0 = 2.5$; Deflection Amplification Factor, $C_d = 2.0$. The maximum panel height-to-width ratio shall be 1:1. Building height is limited by IBC Section 503 and 504.

4.8.3 Seismic Design Categories D, E, and F: Shear wall configurations in [Table 4](#) may be used in Seismic Design Categories A through F. The following factors shall be used for design to resist seismic forces: Response Modification Coefficient $R = 6-1/2$; System Overstrength Factor, $\Omega_0 = 3$; Deflection Amplification Factor, $C_d = 4$. The maximum panel height-to-width ratio shall be 1:1. In Seismic Design Categories D through F, building height shall be the lesser of 65 ft and IBC Sections 503 and 504. The axial capacity of shearwalls used in Seismic Design Categories D, E, and F is limited to 11 percent of the value in [Table 2](#).

4.9 Roof Exterior: Boxabl SIP roofs shall be protected by an approved roof covering.

4.10 Wall Exterior: Boxabl SIPs installed and sealed in accordance with this report and the manufacturer's installation instructions meet the requirements of IBC Section 1402.2 Exception 2 and do not require additional weather protection.

4.10.1 Sealing Panel Joints: EPDM seals ([Figure 6](#)) are used in all PVC profiles connecting panels at corners and at wall-to-wall, roof-to-roof, and floor-to-floor.

4.10.2 Sealant: A 3/8-inch (9.5 mm) bead of DAP Dynaflex 230 sealant is applied outboard of each EPDM seal. A 3/8-inch (9.5 mm) bead of DAP Dynaflex 230 sealant is applied between door and window flanges and the exterior SIP facing.

4.11 Interior Finish: Boxabl SIPs wall and roof panels have a Class A interior finish when tested in accordance with ASTM E84 and have been tested in accordance with IBC 2603.9 and meet the requirements of 2603.4.1.14 and do not require the additional thermal barrier as specified in IBC 2603.4.

5.0 CONDITIONS OF USE:

The Boxabl Structural Insulated Panels described in this report complies with, or is a suitable alternative to what is specified in, those codes listed in Section 1.0 of this report, subject to the following conditions:



- 5.1 Boxabl SIPs are fabricated, identified, and erected in accordance with this report and the manufacturer's published installation instructions. If there is a conflict between this report and the manufacturer's instructions, the more restrictive governs.
- 5.2 Design loads to be resisted by the SIP must be determined in accordance with the IBC or IRC, as applicable, and must not exceed the allowable loads noted in this report.
- 5.3 This report applies only to the panel thicknesses and lengths specifically listed herein.
- 5.4 The SIPs are limited to use in buildings of Type V construction.
- 5.5 Wood-based materials must be protected from decay and termite damage in accordance with IBC Section 2304.12 and IRC Section R317.
- 5.6 Shear walls constructed of SIPs, used in buildings in Seismic Design Categories C through F, must be subject to special inspection in accordance with Section 4.8.1.
- 5.7 Shear walls used in seismic design categories D through F collectors and their connections, bearing and anchorage of the Lateral Force Resisting Vertical Assemblies (LFRVA) and the lateral load path to the LFRVA are designed in accordance with the special load combinations of Section 12.4.3 of ASCE/SEI 7, using E_m , where E_m is computed using the maximum observed overstrength of the LFRVA test specimens of the specific LFRVA configuration.
- 5.8 The Boxabl SIPs are manufactured under a quality control program with inspections by ICC-ES.

6.0 EVIDENCE SUBMITTED

- 6.1 Data in accordance with the [ICC-ES Acceptance Criteria for Sandwich Panels \(AC04\)](#), dated June 2019 (editorially revised December 2020).
- 6.2 Reports of fire testing in accordance with NFPA 286.
- 6.3 Report on resistance to water penetration in accordance with ASTM E331 and IBC Section 1402.2 Exception 2.
- 6.4 Reports of cyclic racking shear load testing in accordance with ASTM E2126.

7.0 IDENTIFICATION

- 7.1 The ICC-ES mark of conformity, electronic labeling, or the evaluation report number (ICC-ES ESR-4725) along with the name, registered trademark, or registered logo of the report holder must be included in the product label.
- 7.2 In addition, each Boxabl SIP is marked with the project or batch number, and the manufacturing location.
- 7.3 The report holder's contact information is the following:

BOXABL
5345 EAST NORTH BELT ROAD,
NORTH LAS VEGAS, NEVADA 89115



Table 1: Transverse Load Capacity (psf)

Panel Configuration	L/180	L/240	L/360
Floor and Roof Panel, Positive Wind Load ^{1,3} (113.875-inch long)	31.3	31.3	31.3
Floor and Roof Panel, Negative Wind Load ^{2,3} (113.875-inch long)	86.7	86.7	63.5
Wall Panel, Positive Wind Load ^{1,4} (113.875-inch long)	38.3	38.3	38.3
Wall Panel, Negative Wind Load ^{2,4} (113.875-inch long)	36.6	36.6	36.6

For SI: 1 inch=25.4 mm, 1 psf= 47.88 Pa.

¹Positive wind load direction indicates force applied to the metal facing of the panel (outside surface) towards the MgO facing of the panel (inside surface).

²Negative wind load direction indicates force applied to the MgO facing of the panel (inside surface) towards the metal facing of the panel (outside surface).

³Roof and floor panels are supported with 3 inches of bearing on one end and 6 inches bearing on the other end.

⁴Wall panel allowable loads are based on panels supported through the end caps.

**Table 2: Axial Load Capacity^{1,2}**

Panel Configuration	Allowable Load (plf)
113.875-inch Wall Height	2200

For SI: 1 inch=25.4 mm, 1 plf = 14.59 N/m.

¹Tabulated axial load is the maximum uniform load (pounds per linear foot) applied concentrically to the full thickness of the SIP, including facings, to the top. Eccentric axial loading to one face of the SIP is outside the scope of this report.

²For combined loading, the requirements of Section 4.1 must be applied.

Table 3: Seismic Design Categories A, B, and C Shearwall Racking Load Capacity¹

Panel Configuration	Allowable Load (plf)
113.875-inch Wall Height	349

For SI: 1 inch=25.4 mm, 1 plf = 14.59 N/m.

¹Shearwall capacity limited to walls with a 1:1 (h:w) aspect ratio.

²This shearwall design is limited to use in Seismic Design Categories A, B, and C.

Table 4: Seismic Design Categories A through F Shearwall Racking Load Capacity¹

Panel Configuration	Allowable Load (plf)
113.875-inch Wall Height	127

For SI: 1 inch=25.4 mm, 1 plf = 14.59 N/m.

¹Shearwall capacity limited to walls with a 1:1 (h:w) aspect ratio.

²Axial capacity of shearwalls used in Seismic Design Categories D, E, and F is limited to 11% of the value in [Table 2](#).

³The deflection at allowable shear load is 0.25 inches (6 mm).

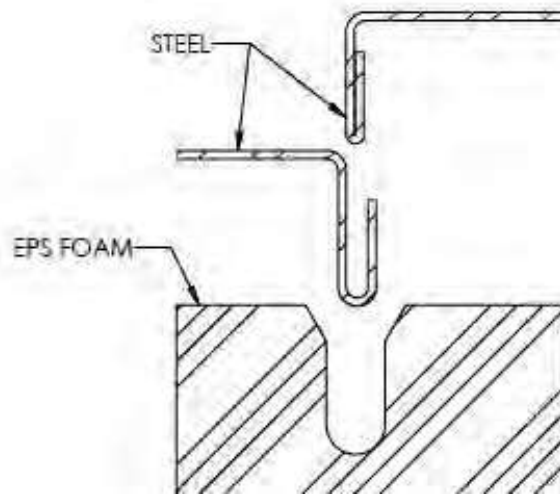

Figure 1: Steel Facing Hem Insert into EPS Core

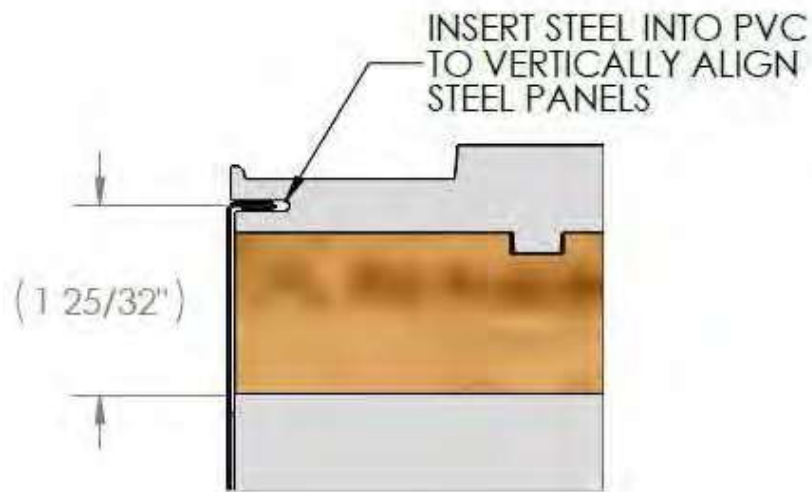

Figure 2: Steel Facing Hem Insert into PVC Endcap

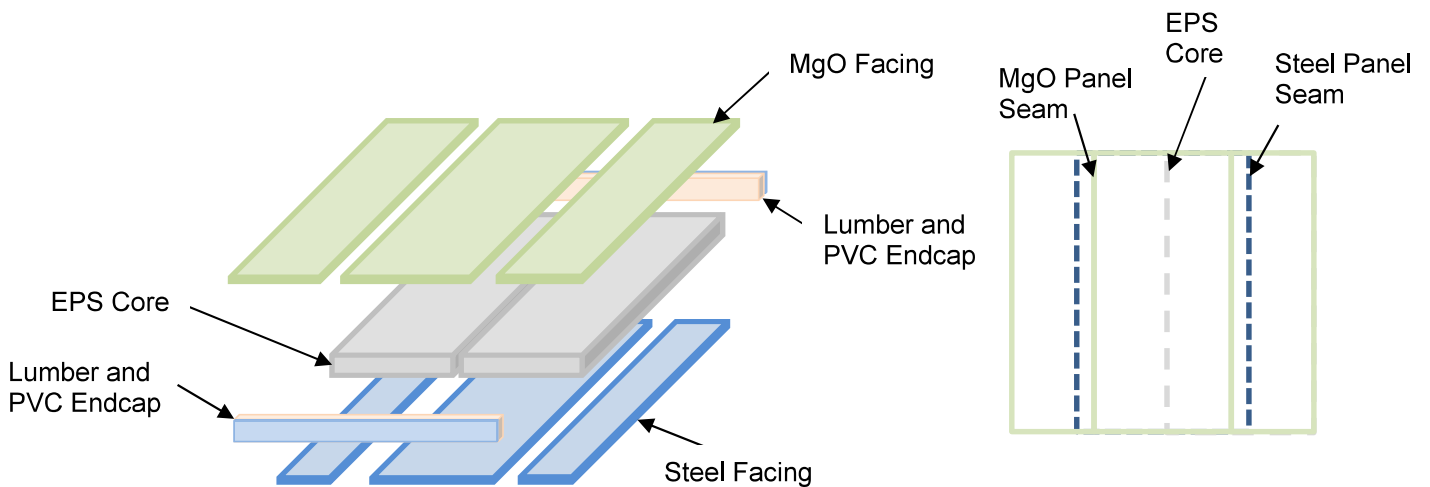

Figure 3: Panel Construction and Staggered Seams

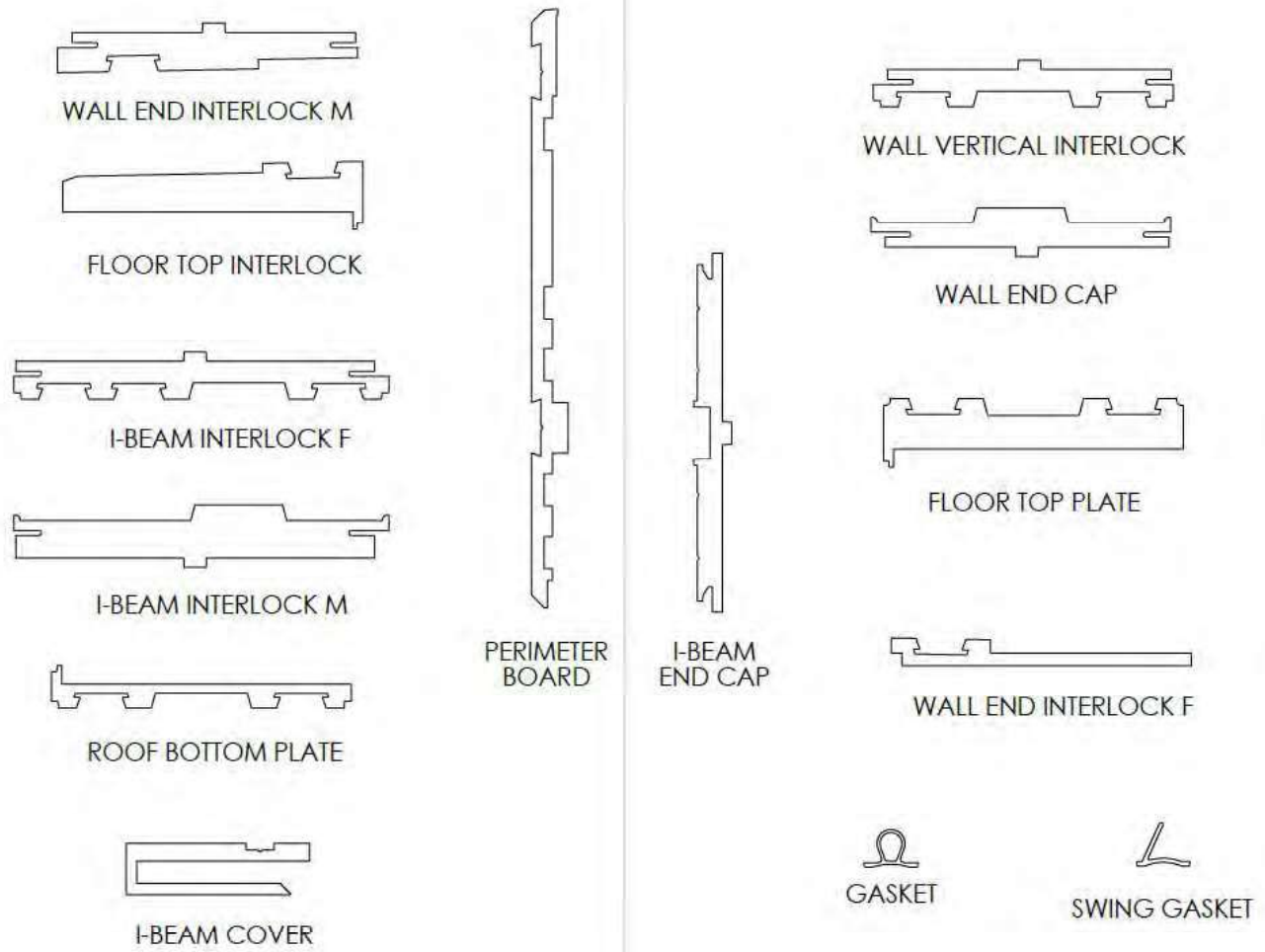

Figure 4: PVC Panel Connectors



Figure 5: EPDM Seals

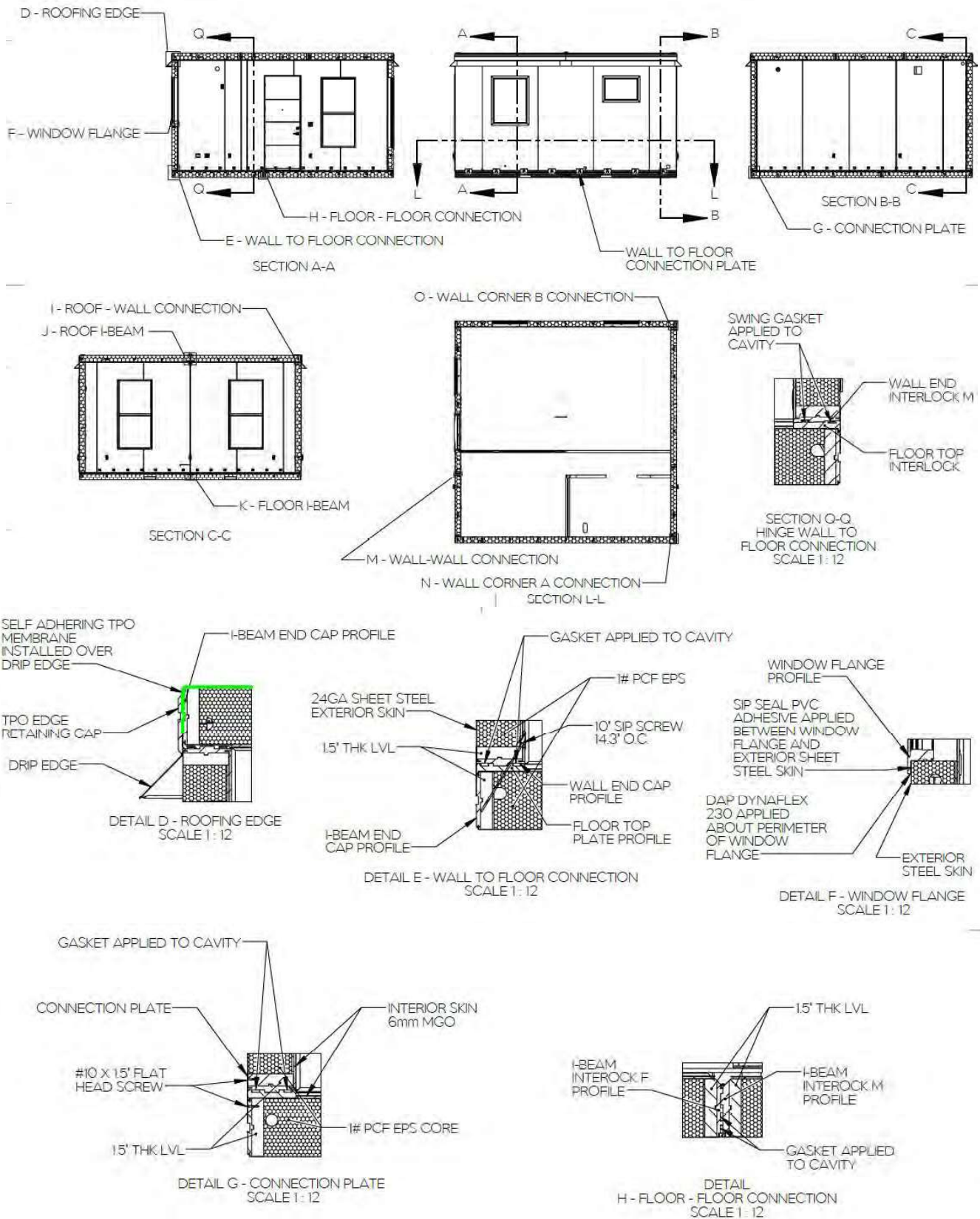

Figure 6: Panel Connections



ICC-ES Evaluation Report

ESR-4725 LABC and LARC Supplement

Reissued May 2024.

This report is subject to renewal May 2025.

www.icc-es.org | (800) 423-6587 | (562) 699-0543

A Subsidiary of the International Code Council®

DIVISION: 06 00 00—WOOD, PLASTICS AND COMPOSITES

Section: 06 12 00—Structural Panels

REPORT HOLDER:

Boxabl

EVALUATION SUBJECT:

BOXABL STRUCTURAL INSULATED PANELS (SIPs)

1.0 REPORT PURPOSE AND SCOPE

Purpose:

The purpose of this evaluation report supplement is to indicate that Boxabl Structural Insulated Panels, described in ICC-ES evaluation report [ESR-4725](#), have also been evaluated for compliance with the codes noted below as adopted by the Los Angeles Department of Building and Safety (LADBS).

Applicable code editions:

- 2023 *City of Los Angeles Building Code* (LABC)
- 2023 *City of Los Angeles Residential Code* (LARC)

2.0 CONCLUSIONS

The Boxabl Structural Insulated Panels, described in Sections 2.0 through 7.0 of the evaluation report [ESR-4725](#), comply with the LABC Chapter 14, 15, 16 and 26, and the LARC, and are subject to the conditions of use described in this supplement.

3.0 CONDITIONS OF USE

The Boxabl Structural Insulated Panels described in this evaluation report supplement must comply with all of the following conditions:

- All applicable sections in the evaluation report [ESR-4725](#).
- The design, installation, conditions of use and identification of the *Structural Insulated Panels* are in accordance with the 2021 *International Building Code*® (IBC) provisions noted in the evaluation report [ESR-4725](#).
- The design, installation and inspection are in accordance with additional requirements of LABC Chapters 16 and 17, as applicable.
- Under the LARC, an engineered design in accordance with LARC Section R301.1.3 must be submitted.

This supplement expires concurrently with the evaluation report, reissued May 2024.

ICC-ES Evaluation Reports are not to be construed as representing aesthetics or any other attributes not specifically addressed, nor are they to be construed as an endorsement of the subject of the report or a recommendation for its use. There is no warranty by ICC Evaluation Service, LLC, express or implied, as to any finding or other matter in this report, or as to any product covered by the report.





ICC-ES Evaluation Report

ESR-4725 CBC and CRC Supplement

Reissued May 2024

This report is subject to renewal May 2025.

www.icc-es.org | (800) 423-6587 | (562) 699-0543

A Subsidiary of the International Code Council®

DIVISION: 06 00 00—WOOD, PLASTICS AND COMPOSITES

Section: 06 12 00—Structural Panels

REPORT HOLDER:

Boxabl

EVALUATION SUBJECT:

BOXABL STRUCTURAL INSULATED PANELS (SIPs)

1.0 REPORT PURPOSE AND SCOPE

Purpose:

The purpose of this evaluation report supplement is to indicate that Boxabl SIPs, described in ICC-ES evaluation report ESR-4725, have also been evaluated for compliance with the code(s) noted below.

Applicable code edition(s):

- 2022 California Building Code (CBC)

For evaluation of applicable Chapters adopted by the California Office of Statewide Health Planning and Development (OSHPD) AKA: California Department of Health Care Access and Information (HCAI) and the Division of State Architect (DSA), see Sections 2.1.1 and 2.1.2 below.

- 2022 California Residential Code (CRC)

2.0 CONCLUSIONS

2.1 CBC:

The Boxabl Structural Insulated Panels, described in Sections 2.0 through 7.0 of the evaluation report ESR-4725, comply with CBC Chapters 14, 15, 16, and 26, provided the design and installation are in accordance with the 2021 *International Building Code*® (IBC) provisions noted in the evaluation report and the additional requirements of CBC of Chapters 16, 17 and 26, as applicable.

2.1.1 OSHPD: The applicable OSHPD Sections and Chapters of the CBC are beyond the scope of this supplement.

2.1.2 DSA: The applicable DSA Sections and Chapters of the CBC are beyond the scope of this supplement.

2.2 CRC:

The Boxabl Structural Insulated Panels, described in Sections 2.0 through 7.0 of the evaluation report ESR-4725, complies with CRC Chapter 3, 5, 6, and 8 provided the design and installation are in accordance with the 2021 *International Residential Code*® (IRC) provisions noted in the evaluation report and the additional requirements of the CRC as applicable.

This supplement expires concurrently with the evaluation report, reissued May 2024.

ICC-ES Evaluation Reports are not to be construed as representing aesthetics or any other attributes not specifically addressed, nor are they to be construed as an endorsement of the subject of the report or a recommendation for its use. There is no warranty by ICC Evaluation Service, LLC, express or implied, as to any finding or other matter in this report, or as to any product covered by the report.





www.icc-es.org | (800) 423-6587 | (562) 699-0543

A Subsidiary of the International Code Council®

ICC-ES Evaluation Report ESR-1962

Reissued July 2023

Revised October 2023

This report is subject to renewal July 2025.

DIVISION: 07 00 00—THERMAL AND MOISTURE PROTECTION

Section: 07 21 00—Thermal Insulation

Section: 07 22 00—Roof and Deck Insulation

Section: 07 25 00—Water-Resistive Barriers/Weather Barriers

REPORT HOLDER:

ATLAS MOLDED PRODUCTS, A DIVISION OF ATLAS ROOFING CORPORATION

EVALUATION SUBJECT:

ATLAS OEM, THERMALSTAR®, DURATHERM, ATLAS GEOFOAM, THERMALSTAR INSULATION BOARD, THERMALSTAR T&G BOARD (T&G I, T&G II, T&G IIR), THERMALSTAR GPS T&G II, THERMALSTAR INTER-GRADE BOARD EPS, TALONGUARD TREATED EPS, THERMALSTAR EIFS, THERMALSTAR TAPER, THERMALSTAR FLUTE FILL AND THERMALSTAR LCI, THERMALSTAR LWi, THERMALSTAR LRi AND THERMALSTAR SWi LAMINATED INSULATION BOARD

1.0 EVALUATION SCOPE

1.1 Compliance with the following codes:

- 2018, 2015, 2012 and 2009 *International Building Code*® (IBC)
- 2018, 2015, 2012 and 2009 *International Residential Code*® (IRC)
- 2018, 2015, 2012 and 2009 *International Energy Conservation Code*® (IECC)

Properties evaluated:

- Surface-burning characteristics
- Thermal resistance (*R*-values)
- Physical properties
- Attic and crawl space installation
- Elimination of thermal barrier (ThermalStar Insulation Board, ThermalStar Taper and ThermalStar Flute Fill used in roofing)
- Termite resistance (TalonGuard Treated EPS)
- Water-resistive barrier (ThermalStar LWi and ThermalStar SWi Laminated Insulation)

1.2 Evaluation to the following green code(s) and/or standards:

- 2022 California Green Building Standards Code (CALGreen), Title 24, Part 11
- 2020, 2015, 2012 and 2008 ICC 700 *National Green Building Standard*™ (ICC 700-2020, ICC 700-2015, ICC 700-2012 and ICC 700-2008)

Attributes verified:

See Sections 2.5 and 2.8

2.0 USES

2.1 Atlas OEM, ThermalStar®, DuraTherm, and Atlas Geofoam Expanded Polystyrene Insulation Boards:

Atlas OEM, ThermalStar®, DuraTherm, and Atlas Geofoam expanded polystyrene (EPS) insulation boards are used as nonstructural thermal insulation in buildings of any construction type, and as components of Class A, B, and C roof covering systems installed on steel decks, when installed in accordance with this report. The insulation is for use in wall cavities, ceiling assemblies, and roof covering assemblies, or on the outside faces of exterior walls. The insulation may be used as roof insulation when recognized in a current ICC-ES evaluation report on the roof covering system, or when installed as described in Section 4.2. The insulation boards may also be directly exposed in attics and crawl spaces without a covering when installed as described in Section 4.2.2. The insulation may also be used as exterior perimeter insulation around concrete slab edges, on foundation walls, or under flat concrete slab on grade construction, except in areas where the probability of termite activity is “very heavy” as noted in Section 5.5.

When installed in accordance with Section 4.2.2 of this report, the insulation boards may be used on both walls and ceilings in attics and crawl spaces, with no thermal barrier or ignition barrier applied to the exposed foam plastic insulation.

2.2 ThermalStar T&G Board (T&G I, T&G II, T&G IIR):

When installed in accordance with this report, ThermalStar T&G Boards are used as nonstructural thermal insulation in buildings of any construction type, as a component of a one-coat cementitious exterior wall coating system. The insulation is for use on the outside faces of exterior walls when an ASTM C578 Type I or Type II EPS board is

ICC-ES Evaluation Reports are not to be construed as representing aesthetics or any other attributes not specifically addressed, nor are they to be construed as an endorsement of the subject of the report or a recommendation for its use. There is no warranty by ICC Evaluation Service, LLC, express or implied, as to any finding or other matter in this report, or as to any product covered by the report.



recognized in a current ICC-ES evaluation report for a one-coat cementitious exterior wall coating system, or when installed as described in Section 4.3. The insulation may also be directly exposed in attic and crawl spaces without a covering when installed as described in Section 4.2.2. Additionally, the insulation may be used as exterior perimeter insulation around concrete slab edges, on concrete or masonry foundation walls, or under flat concrete slab on grade construction, except in areas where the probability of termite activity is "very heavy" as noted in Section 5.5.

2.3 ThermalStar GPS T&G II Board:

When installed in accordance with Section 4.4 of this report, ThermalStar GPS T&G II Boards are used as nonstructural thermal insulation in buildings of any construction type, as a component of a one-coat cementitious exterior wall coating system. The insulation is for use on the outside faces of exterior walls when an ASTM C578 Type II EPS board is recognized in a current ICC-ES evaluation report for a one-coat cementitious exterior wall coating system.

2.4 ThermalStar Inter-Grade Board EPS:

ThermalStar Inter-Grade Board EPS, in thicknesses up to 4 inches (101.4 mm), is for use when installed in residential basements with a thermal barrier in accordance with IRC Section R316.

2.5 TalonGuard Treated Expanded Polystyrene:

TalonGuard treated boards are for the same uses as Atlas OEM, ThermalStar®, DuraTherm, and Atlas Geofoam EPS insulation boards and are recognized for use on the exterior face of foundation walls, under interior or exterior foundation walls or slab foundations below grade, or where located within 6 inches (152 mm) of exposed earth. When installed in areas where the probability of termite infestations is very heavy as described in 2018 and 2015 IBC Section 2603.8, 2012 IBC Section 2603.9; 2009 IBC Section 2603.8; or 2018, 2015, 2012 and 2009 IRC Section R318.4, use is limited to areas exposed to the *Reticulitermes* species.

The attributes of the TalonGuard treated boards have been verified as conforming to the provisions of (i) ICC 700-2015 and ICC 700-2012 Sections 602.1.6 and 11.602.1.6; and (ii) ICC 700-2008 Section 602.8. Note that decisions on compliance for those areas rest with the user of this report. The user is advised of the project-specific provisions that may be contingent upon meeting specific conditions, and the verification of those conditions is outside the scope of this report. These standards often provide supplemental information as guidance.

2.6 ThermalStar EIFS:

When installed in accordance with this report, ThermalStar EIFS is an EPS foam plastic insulation board used as nonstructural thermal insulation as a component in exterior insulation and finish systems (EIFS). The insulation may be used on the outside faces of exterior walls when an ASTM C578 Type I EPS board is recognized in a current ICC-ES evaluation report for an EIFS.

2.7 ThermalStar Taper, ThermalStar Insulation Board and ThermalStar Flute Fill:

ThermalStar Taper, ThermalStar Insulation Board and ThermalStar Flute Fill insulation boards are EPS foam plastic insulation used as nonstructural thermal insulation as components of a Class A, B, or C roof covering system installed directly to steel decks when recognized in a current ICC-ES evaluation report, or when installed as described in Section 4.7 of this report.

2.8 ThermalStar LCi, ThermalStar LRi, ThermalStar LWi and ThermalStar SWi Laminated Insulation:

ThermalStar LRi is an EPS foam plastic insulation board used as nonstructural thermal insulation as components of a Class A, Class B or Class C roof covering system, when specified in a current ICC-ES evaluation report for the roof covering system. ThermalStar LCi is an EPS foam plastic insulation board used as nonstructural thermal insulation in crawlspaces when installed in accordance with Sections 4.2.1 and 4.2.2 of this report. ThermalStar LWi and ThermalStar SWi Laminated Insulation board are EPS foam plastic insulation boards used as nonstructural thermal insulation when installed in accordance with Sections 4.2.1 and 4.2.2 of this report. ThermalStar LWi and ThermalStar SWi insulation may be used on the outside faces of exterior walls when an ASTM C578 Type I or Type II EPS board is recognized in a current ICC-ES evaluation report for a one-coat cementitious exterior wall coating system, or when installed as described in Section 4.2.1 of this report.

The ThermalStar LWi and ThermalStar SWi Laminated Insulation boards may be used as an alternative to the water-resistive barriers specified in the codes when installed in accordance with Section 4.8.1.

ThermalStar LWi may be used when an ASTM C578 Type I or Type II EPS board is specified in a current ICC-ES evaluation report for a one-coat cementitious exterior wall covering system, see Table 3 for minimum density compressive strength and flexural strength.

The attributes of the ThermalStar LWi and ThermalStar SWi Laminated Insulation boards used as a water-resistive barrier have been verified as conforming to the provisions of (i) CALGreen Section 5.407.1 and (ii) ICC 700-2020 Sections 602.1.8, 11.602.1.8, 1202.6 and 13.104.1.4; (iii) ICC 700-2015 Section 602.1.8, 11.602.1.8 and 12.6.602.1.8; (iv) ICC 700-2012 Section 602.1.8, 11.602.1.8 and 12.5.602.1.8; and (v) ICC 700-2008 Section 602.9 for water-resistive barriers. Note that decisions on compliance for those areas rest with the user of this report. The user is advised of the project-specific provisions that may be contingent upon meeting specific conditions, and the verification of those conditions is outside the scope of this report. These codes or standards often provide supplemental information as guidance.

3.0 DESCRIPTION

3.1 General:

The Atlas Molded Products EPS insulation boards, at a maximum thickness of 4 inches (102 mm) and a nominal density of 2.0 pcf (32 kg/m³), have a flame-spread index not exceeding 25 and a smoke-developed index not exceeding 450 when tested in accordance with ASTM E84. Boards are alternately white or light orange color. See Table 1 for applicable use of the products.

3.2 Atlas OEM, ThermalStar®, DuraTherm, and Atlas Geofoam Expanded Polystyrene Insulation Boards:

Atlas OEM, ThermalStar®, DuraTherm, and Atlas Geofoam Expanded Polystyrene (EPS) insulation boards comply with ASTM C578 and are molded, closed-cell boards manufactured at minimum densities of 0.90, 1.15, 1.35, 1.80 and 2.40 pcf (14.4, 18.4, 21.6, 28.8 and 38.4 kg/m³). The designations for the five densities are Type I, Type VIII, Type II, Type IX, and Type XIV, respectively. For thermal resistance (*R*-values), see Table 2.

The EPS insulation boards are produced in various thicknesses up to 6 inches (152 mm), and in various sizes, with square, shiplap or tongue-and-groove edge profiles.

3.3 ThermalStar T&G Board (T&G I, T&G II, T&G IIR):

ThermalStar T&G Board insulation is molded, closed-cell, EPS foam plastic insulation board complying with the Type I and Type II requirements of ASTM C578. The board insulation is molded at minimum densities of 0.90 pcf (14.4 kg/m³) for T&G I and 1.35 pcf (21.6 kg/m³) for T&G II and T&G IIR. For thermal resistance (*R*-values), see Table 2.

The ThermalStar T&G Board insulation consists of nominally 1-inch-thick (25 mm) boards produced in various sizes, with shiplap or tongue-and-groove edge profiles.

3.4 ThermalStar GPS T&G II Board:

ThermalStar GPS T&G II Board insulation is black, closed-cell, EPS graphite enhanced foam plastic insulation board complying with the Type II requirements of ASTM C578. The board insulation is molded at minimum density of 1.35 pcf (21.6 kg/m³). For thermal resistance (*R*-values), see Table 2.

The ThermalStar GPS T&G II Board insulation consists of nominally 1.06-inch-thick (27 mm) boards produced in various sizes, with shiplap or tongue-and-groove edge profiles.

3.5 ThermalStar Inter-Grade Board EPS:

ThermalStar Inter-Grade Board EPS insulation is white or orange molded, closed-cell, foam plastic insulation board complying with the Type I requirements of ASTM C578. The board insulation is molded at minimum density of 0.90 pcf (14.4 kg/m³). For thermal resistance (*R*-values), see Table 2.

The ThermalStar Inter-Grade Board EPS insulation consists of maximum 4-inch-thick (101.4 mm) boards produced in various sizes, with shiplap or tongue-and-groove edge profiles.

3.6 TalonGuard Treated Expanded Polystyrene Boards:

TalonGuard treated boards are similar to EPS insulation boards described in Section 3.2 of this report and comply with ASTM C578. The insulation boards are used as described in Section 2.5 of this report when installed as described in Section 4.5.

3.7 ThermalStar EIFS:

ThermalStar EIFS is molded, closed-cell, EPS insulation board complying with the Type I requirements of ASTM C578 and ASTM E2430. The EPS insulation board is manufactured at a minimum density of 0.90 pcf (14.4 kg/m³). For thermal resistance (*R*-values), see Table 2.

The ThermalStar EIFS is produced in various thicknesses up to 6 inches (152 mm), and in various sizes, with square, shiplap or tongue-and-groove edge profiles.

3.8 ThermalStar Taper, ThermalStar Insulation Board and ThermalStar Flute Fill:

ThermalStar Taper, ThermalStar Insulation Board and ThermalStar Flute Fill insulation boards comply with ASTM C578 and are molded, closed-cell, EPS boards manufactured at minimum densities of 0.90, 1.15, 1.35 and 1.80 pcf (14.4, 18.4, 21.6 and 28.8 kg/m³). The ThermalStar designations for the four densities are, respectively, (Type I), (Type VIII), (Type II) and (Type IX). For thermal resistance (*R*-values), see Table 2.

The ThermalStar Taper, ThermalStar Insulation Board and ThermalStar Flute Fill insulation boards are produced in flat, tapered or flute-shaped boards, up to a thickness of

9 inches (229 mm) for (Type I), 7.2 inches (183 mm) for (Type VIII), 6.0 inches (152 mm) for (Type II), and 4.5 inches (114 mm) for (Type IX). The boards are produced in various sizes, with square, shiplap or tongue-and-groove edge profiles.

3.9 ThermalStar LCi, ThermalStar LRI, ThermalStar SWi, and ThermalStar LWi Laminated Insulation:

ThermalStar LCi, ThermalStar LRI, ThermalStar SWi, and ThermalStar LWi Laminated Insulation boards are molded, closed-cell, EPS boards with polyethylene or polypropylene film facers adhered to both sides. ThermalStar SWi is surfaced on one side with a nominal 0.108-inch-thick (2.74 mm) cellulosic fiberboard. When an ASTM C578 Type I or Type II EPS board is specified in a current ICC-ES evaluation report for a one-coat cementitious exterior wall covering system, the core material of ThermalStar LWi is a Type I EPS manufactured at a minimum density of 0.9 pcf (14.4 kg/m³). See Table 3 for minimum density, compressive strength and flexural strength. The facing is bonded to the EPS core with adhesive and is cured under factory-controlled conditions.

The ThermalStar LCi, ThermalStar LRI, ThermalStar SWi, and ThermalStar LWi Laminated Insulation boards are nominally 1 inch (25 mm) to 4 inch (101 mm) thick and are produced in various sizes, with square, shiplap or tongue-and-groove edge profiles. For minimum density and thermal resistance (*R*-values), see Table 2. The core material may be a minimum density of either 0.90 pcf (14.4 kg/m³), 1.15 pcf (18.4 kg/m³), 1.35 pcf (21.6 kg/m³) or 1.80 pcf (28.8 kg/m³).

3.10 ThermalStar Tape:

ThermalStar tape must be used with ThermalStar LCi, ThermalStar LRI, ThermalStar SWi, and ThermalStar LWi Laminated Insulation boards when the board is used as an alternate to the water-resistive barrier as described in Section 4.8.1. The tape consists of a polyethylene backing with a rubber-based adhesive and has a nominal thickness of 6 mils [0.006 inch (0.15 mm)] and a width of 2 inches (51 mm). The tape is supplied in rolls 36 yards (32.9 m) long.

3.11 Potential Heat:

See Table 4 for potential heat content of insulation boards when tested in accordance with NFPA 259.

4.0 INSTALLATION

4.1 General:

Installation of the foam plastic insulation must comply with this report and the manufacturer's published installation instructions. The manufacturer's published installation instructions must be available at all times on the jobsite during installation. The EPS insulation boards must be attached to supports in a manner that will secure the insulation in place.

4.2 Atlas OEM, ThermalStar, DuraTherm, and Atlas Geofoam EPS Insulation Boards:

4.2.1 General: The interior of the building must be separated from the insulation boards with a thermal barrier as required in IBC Section 2603.4, or 2018, 2015, 2012 and 2009 IRC Section R316.4, as applicable, except as described in Section 4.2.2 of this report. Under the 2018, 2015, 2012 and 2009 IBC, protection against condensation must be provided in accordance with Section 1403.2. A vapor retarder must be provided in accordance with 2018, 2015 and 2012 IRC Section R702.7 or 2009 IRC Section R601.3. A water-resistive barrier in compliance with IBC Section 1404.2 and IRC Section R703.2, is required and,

when applied over wood-based sheathing, must comply with IBC Section 2510.6, 2018 IRC Section R703.7.3 or 2015, 2012, 2009 IRC Section R703.6.3, as applicable. The insulation board is permitted to be applied to exterior faces of walls, to a maximum thickness of 1½ inches (38 mm), except insulation board thicknesses greater than 1½ inches (38 mm) may be permitted if such installation is recognized in an ICC-ES evaluation report on wall coverings or when attachment of claddings is in accordance with the prescriptive requirements of 2018 and 2015 IBC Sections 2603.11 or 2603.12 or 2018 and 2015 IRC Sections R703.15, R703.16 or R703.17. The attachment of finish materials over the insulation board must provide a minimum 1-inch (25.4 mm) penetration of the fasteners into wood framing members. Exterior wall assembly, exterior finish or a wall covering over the insulation boards must be structurally adequate to resist the required horizontal forces perpendicular to the wall.

The insulation boards must not be used structurally to resist transverse, vertical or in-plane loads. The boards must not be used as exterior stud wall bracing. Wall bracing must be provided in accordance with the applicable code. All walls must be braced in accordance with 2018 and 2015 IBC Section 2308.6, 2012 and 2009 IBC Sections 2308.9.3 and 2308.12.4, IRC Section R602.10, as applicable.

The insulation boards must not be used as a nailing base for exterior siding materials. All fastening must be made through the boards and either into the wall framing or into structural sheathing, as required by the siding manufacturer's published installation instructions, or in accordance with the applicable code.

4.2.2 Attics and Crawl Spaces:

4.2.2.1 Where ThermalStar EIFS; Atlas OEM, ThermalStar Insulation Board, DuraTherm, and Atlas Geofoam Type I, II, VIII and IX EPS insulation boards; TalonGuard Treated EPS Type I, II, VIII and IX; ThermalStar T&G Boards (T&G I, T&G II, T&G IIR) and ThermalStar LCi, ThermalStar LRi, ThermStar SWi and ThermalStar LWi Laminated Insulation boards, with a maximum nominal thickness of 2 inches (50.8 mm) and a maximum density of 2.0 pcf (32 kg/m³), are installed with mechanical fasteners on vertical walls and the underside of the surface above in attics and crawl spaces, the prescriptive ignition barrier required by IBC Section 2603.4.1.6 and IRC Sections R316.5.3 and R316.5.4 may be omitted, where the following conditions apply:

- a. Attic ventilation is provided when required by 2018 IBC Section 1202.2, 2015, 2012 and 2009 IBC Section 1203.2 or IRC Section R806, as applicable, except unvented attic assemblies are permitted under the conditions prescribed in 2018, 2015 and 2012 IRC Section R806.5 (2009 IRC Section R806.4).
- b. Under-floor (crawl space) ventilation is provided when required by 2018 IBC Section 1202.4, 2015, 2012 and 2009 IBC Section 1203.3 or IRC Section R408.1, as applicable, except unvented crawl spaces are permitted under the conditions prescribed in 2018, 2015 and 2012 IRC Section R408.3.
- c. Combustion air is provided in accordance with IMC (*International Mechanical Code*)[®] Section 701.

4.2.2.2 Where Inter-Grade and ThermalStar Insulation Board insulation boards, with a maximum nominal thickness of 4 inches (101.6 mm) and a maximum density of 1.0 pcf (16 kg/m³), are installed with mechanical fasteners only on vertical walls in attics and crawl spaces, the prescriptive ignition barrier required by IBC Section 2603.4.1.6 and IRC

Sections R316.5.3 and R316.5.4 may be omitted, where the following conditions apply:

- a. Attic ventilation is provided when required by 2018 IBC Section 1202.2, 2015, 2012 and 2009 IBC Section 1203.2 or IRC Section R806, as applicable, except unvented attic assemblies are permitted under the conditions prescribed in 2015 and 2012 IRC Section R806.5 (2009 IRC Section R806.4).
- b. Under-floor (crawl space) ventilation is provided when required by 2018 IBC Section 1202.4, 2015, 2012 and 2009 IBC Section 1203.3 or IRC Section R408.1, as applicable, except unvented crawl spaces are permitted under the conditions prescribed in 2018, 2015 and 2012 IRC Section R408.3.
- c. Combustion air is provided in accordance with IMC (*International Mechanical Code*)[®] Section 701.

4.3 ThermalStar T&G Board (T&G I, T&G II, T&G IIR):

ThermalStar T&G Board must be installed in accordance with a current ICC-ES evaluation report on a one-coat cementitious exterior wall coating system. The insulation may also be installed in attic and crawl spaces without a covering as described in Section 4.2.2 of this report. The insulation boards may also be installed as exterior perimeter insulation around concrete slab edges, on concrete or masonry foundation walls, or under flat concrete slab on grade construction, except in areas where the probability of termite activity is "very heavy" as noted in Section 5.5.

4.4 ThermalStar GPS T&G Board:

ThermalStar GPS T&G Board must be installed in accordance with a current ICC-ES evaluation report on a one-coat cementitious exterior wall coating system.

4.5 TalonGuard Treated Expanded Polystyrene:

TalonGuard treated insulation boards must be installed in the same manner as described for Atlas OEM, ThermalStar, DuraTherm, and Atlas Geofoam EPS insulation boards in Section 4.2.

4.6 ThermalStar EIFS:

ThermalStar EIFS insulation must be installed as part of an EIFS system in accordance with the current ICC-ES evaluation report on the EIFS.

4.7 ThermalStar Taper, ThermalStar Insulation Board and ThermalStar Flute Fill:

4.7.1 Application Directly to Steel Roof Decks without a Thermal Barrier: ThermalStar roof insulation boards (ThermalStar Taper, ThermalStar Insulation Board, ThermalStar Flute Fill) may be used as a component of a Class A, B or C roof covering installed on steel decks without a thermal barrier, when installed in accordance with this section (Section 4.7) of this report.

4.7.2 Materials:

4.7.2.1 Steel Deck: Steel roof decking must be minimum No. 22 gage [0.030 inch (0.76 mm)], 1½-inch-deep (38 mm), unperforated, galvanized steel decking, with flutes spaced a maximum of 6 inches (152 mm) on center. The deck must be welded or mechanically fastened to structural supports in accordance with the applicable code.

4.7.2.2 Foam Plastic Insulation: The ThermalStar roof insulation boards are recognized for use on steel decks without a thermal barrier. The ThermalStar roof insulation boards are limited to have maximum thicknesses as follows: up to 9 inches (229 mm) for (Type I), 7.2 inches (183 mm) for (Type VIII), 6.0 inches (152 mm) for (Type II), and 4.5 inches (114 mm) for (Type IX).

4.7.2.3 Cover Board: When used, the cover board in the roof-covering system must be either 1/4-inch-thick (6.4 mm) Dens-Deck® Roof Board manufactured by Georgia-Pacific Corporation, or 1/2-inch-thick (12.7 mm) wood-fiber board complying with ASTM C208.

4.7.2.4 Slip Sheet: The slip sheet must be one layer of FR10 or FR50 manufactured by Atlas Roofing Corporation, and may be used as an alternative to the cover board specified for the membrane roof systems noted in Section 4.7.2.3 of this report.

4.7.2.5 Roof Covering: The roof covering membrane must be either an EPDM or a thermoplastic membrane, recognized in a current ICC-ES evaluation report as part of a Class A, B or C roofing covering system. The membrane must be either mechanically attached, fully adhered, or ballasted. Thermoplastic membranes include polyvinyl chloride (PVC), modified PVC, chloro-sulphonated polyethylene (CSPE), and thermoplastic polyolefin (TPO). The membrane must be limited to a maximum nominal thickness of 0.045 inch (1.1 mm) for use under the IBC. The evaluation report on the roof-covering system must specify one of the following systems as the only components of the classified roof-covering system permitted under the conditions of this report:

- a. A generic EPS insulation board, having the same density and installed thickness as the ThermalStar roof insulation boards recognized in Section 4.7.2.2 of this report; the cover board described in Section 4.7.2.3 or the slip sheet described in Section 4.7.2.4; and the mechanically attached roof-covering membrane described in this section, installed over a steel deck described in Section 4.7.2.1.
- b. A generic EPS insulation board, having the same density and installed thickness as the ThermalStar roof insulation recognized in Section 4.7.2.2 of this report; the roof covering membrane described in this section; and stone ballast installed over a steel deck described in Section 4.7.2.1.

4.7.3 Installation: The ThermalStar roof insulation boards must be loosely laid directly over the steel deck in single or multiple layers, to a maximum total thickness as described in Section 4.7.2.2. The top layer of insulation must be placed so that the wording required in item 1 of Section 7.0 is facing up. The optional cover board described in Section 4.7.2.3, or the slip sheet described in Section 4.7.2.4, must be laid over the insulation. The cover board is optional, depending on system requirements, when the method of attaching the roof membrane is either mechanical fastening or adhesion. A cover board is not permitted in the system when the roof membrane is ballasted.

The method of attaching the roof covering, cover board, slip sheet or ballast, and insulation boards to the steel roof deck must be in accordance with the ICC-ES evaluation report on the roof-covering membrane, and as described in Section 4.7.2.5.

4.7.4 Reroofing: New roofing must not be applied over existing roof-covering systems as described in this report, since the fire performance of the systems is directly affected by the materials covering the foam plastic insulation. The components of the existing roofing that are to remain on the roof deck must be inspected in accordance with 2018 and 2015 IBC Section 1511 or 2012 and 2009 IBC Section 1510. The existing roof-covering membrane and, if necessary, the slip sheet or cover board must be removed before new roofing materials are installed; the new roofing materials

must have characteristics specifically described in this report.

4.8 ThermalStar LCi, ThermalStar LRi, ThermalStar SWi and ThermalStar LWi Laminated Insulation:

ThermalStar LCi, ThermalStar LRi, ThermalStar SWi and ThermalStar LWi Laminated Insulation wall insulation boards must be installed as specified for Atlas OEM, ThermalStar Insulation Board, DuraTherm and Atlas Geofoam EPS in Sections 4.2.1 or as described in Section 4.8.1 of this report.

4.8.1 Water-resistive Barrier:

4.8.1.1 General: When installed in accordance with this section, the ThermalStar LCi, ThermalStar LRi, ThermalStar SWi and ThermalStar LWi Laminated Insulation boards combined with ThermalStar tape may be used as an alternative to the water-resistive barrier in 2018 IBC Section 1403.2 (2015, 2012 and 2009 IBC Section 1404.2) and IRC Section R703.2 when installed on exterior walls as described in this section.

The 2- or 4-foot-wide (610 or 1219 mm) ThermalStar LCi, ThermalStar LRi, ThermalStar SWi and ThermalStar LWi Laminated Insulation boards with tongue-and-groove joints on the long edges must be oriented horizontally, with tongues facing upward. The 2- or 4-foot-wide (610 or 1219 mm) boards with square edges may be oriented horizontally or vertically.

The ThermalStar LCi, ThermalStar LRi, ThermalStar SWi and ThermalStar LWi Laminated Insulation boards must be installed directly to framing spaced a maximum of 24 inches on center, except where further limited by the requirements for a wall covering. Fasteners used to attach the boards to framing must be corrosion-resistant roofing nails with a minimum 3/8-inch-diameter (9.5 mm) head; 6d ring-shank nails and 15/16-inch-diameter (24 mm) plastic washers; self-drilling screws with 3/4-inch-diameter (19 mm) cap washers; or 1-inch-wide-crown (25.4 mm), No. 16 gage staples. Fasteners must be spaced at a maximum of 24 inches (610 mm) apart and be long enough to penetrate the framing members a minimum of 3/4 inch (19 mm). Joints between boards must be tightly butted together, and corners created with the boards, must be taped with ThermalStar polyethylene tape centered over the joint. ThermalStar LCi, ThermalStar LRi, ThermalStar SWi and ThermalStar LWi Laminated Insulation boards must be installed with a weep screed, and require the use of self-adhering flashing complying with AAMA 711 or the ICC-ES Acceptance Criteria for Flashing Materials (AC148), around penetrations. The boards must be covered by an approved exterior wall cladding or cementitious wall coating recognized in a current ICC-ES evaluation report.

4.8.1.2 Installation Around Penetrations and Openings:

The system is limited to use with flange-type windows. An AC148-compliant or AAMA 711 compliant flashing material must be installed completely covering the framing sill and extending a minimum of 6 inches (152 mm) up the sides of the opening and approximately 1 1/2 inches (38 mm) beyond the edge of the foam board at the front of the window opening. The sill flashing must be flush with the inside edge of the framing members on the inside of the wall. The flashing extending outside of the ThermalStar LCi, ThermalStar LRi, ThermalStar SWi and ThermalStar LWi Laminated Insulation board must be folded over the front face of the foam board. The flange-type window must then be installed in accordance with the window manufacturer's installation instructions. Jamb flashing must be installed

prior to the installation of the head flashing. All jamb and head flashing must completely cover the window flanges.

Flashing of pipe penetrations must be accomplished by sealing around the pipe with flashing complying with AC148 or AAMA 711. Flashing of other penetrating items must be in accordance with the wall covering manufacturer's instructions.

5.0 CONDITIONS OF USE

The EPS insulation boards described in this report comply with, or are suitable alternatives to what is specified in, those codes listed in Section 1.0 of this report, subject to the following conditions:

- 5.1 The EPS insulation boards must be installed in accordance with this report, the manufacturer's published installation instructions and the applicable code. In the event of a conflict between the installation instructions and this report, this report governs.
- 5.2 The boards must be separated from the building interior with a thermal barrier complying with the applicable code, such as minimum ½-inch-thick (12.7 mm) gypsum wallboard installed in accordance with the applicable code, except as described in Sections 4.2.2, 4.7.1 and 5.8 of this report.
- 5.3 Except for ThermalStar LCI, ThermalStar LRI, ThermalStar SWI and ThermalStar LWI Laminated Insulation boards installed in accordance with Section 4.8.1, when applied on exterior walls, the boards must be protected by a water-resistive barrier complying with IBC Section 1404.2 or IRC Section R703.2, and by wall coverings that provide the necessary structural resistance to wind and seismic forces in spanning between wall framing members. When used as a water-resistive barrier, all ThermalStar LCI, ThermalStar LRI, ThermalStar SWI and ThermalStar LWI Laminated Insulation joints must be backed with a stud or sheathing.
- 5.4 Use of the insulation boards to structurally resist transverse, racking-shear or vertical loading is outside the scope of this report. Walls must be braced in accordance with the applicable code.
- 5.5 In areas where the probability of termite infestation is defined as "very heavy," the foam plastic must be installed in accordance with 2018 and 2015 IBC Section 2603.8, 2012 IBC Section 2603.9; 2009 IBC Section 2603.8; or 2018, 2015, 2012 and 2009 IRC Section R318.4, except as allowed for TalonGuard treated EPS in Section 4.5 of this report.
- 5.6 Jobsite certification and labeling of the insulation must comply with 2018 and 2015 IRC Section N1101.10.1, 2012 IRC Section N1101.12.1, 2009 IRC Section N1101.4, 2018, 2015, 2012 and 2009 IECC Section C303.1.1 or R303.1.1, as applicable.
- 5.7 ThermalStar Tape has not been evaluated by ICC-ES for use as flashing under 2018 IBC Section 1404.4, 2015, 2012 and 2009 IBC Section 1405.4 or 2018 and 2015 Section R703.4, or 2012 and 2009 IRC Section R703.8.
- 5.8 ThermalStar Taper, ThermalStar Insulation Board and ThermalStar Flute Fill insulation boards are installed directly to a steel roof deck without a thermal barrier, the following conditions apply:
 - 5.8.1 The insulation boards must be part of a Class A, B or C roof covering system described in Section 4.7 of this report. The boards are permitted to be

installed without the thermal barrier addressed in IBC Section 2603.4.1.5. The system is not permitted under the IRC.

- 5.8.2 Reroofing must be in accordance with Section 4.7.4.

- 5.9 Boards are manufactured in the locations specified in Table 5 under a quality-control program with inspections by ICC-ES.

6.0 EVIDENCE SUBMITTED

- 6.1 Data in accordance with the ICC-ES Acceptance Criteria for Foam Plastic Insulation (AC12), dated June 2015 (editorially revised October 2017).
- 6.2 Test report in accordance with UL1256.
- 6.3 Test reports in accordance with ASTM E84.
- 6.4 Test reports in accordance with the ICC-ES Acceptance Criteria for Foam Plastic Sheathing Panels Used as Weather-resistive Barriers (AC71), dated February 2003 (editorially revised January 2018).
- 6.5 Test reports in accordance with the ICC-ES Acceptance Criteria for Termite-resistant Foam Plastics (AC239), dated October 2008 (editorially revised February 2018).
- 6.6 Test reports in accordance with NFPA 286.
- 6.7 Test report in accordance with NFPA 259.

7.0 IDENTIFICATION

- 7.1 The Atlas OEM, ThermalStar, DuraTherm, and Atlas Geofoam insulation boards must be packaged in bundles that are labeled with the manufacturer's name (Atlas Molded Products or "AMP") and plant ID; the date of manufacture; the product type (including TalonGuard where applicable); the density; the flame-spread and smoke-developed indices; the thermal-resistance *R*-value (when applicable); and the evaluation report number (ESR-1962).

In addition to the labeling noted above, the following additional labeling is required:

1. When ThermalStar Taper, ThermalStar Insulation Board, ThermalStar Flute Fill roof insulation boards are used in roof-covering assemblies attached directly to steel roof decks under Section 4.7 of this report, in addition to the labeling noted above, the boards must bear the designation "ThermalStar" and the wording "When used in reroofing applications, limits exist for cover board and membrane. See ICC-ES evaluation report ESR-1962 before reroofing"; and the words "THIS SIDE UP" printed on, or included on a permanent label affixed to, one face of each insulation board.
2. The ThermalStar T&G (T&G I, T&G II, T&G IIR) and ThermalStar GPS T&G II insulation boards are individually identified with the Atlas Molded Products name, the product type, the density, the evaluation report number (ESR-1962), and the name of the inspection agency (ICC-ES).
3. ThermalStar T&G (T&G I, T&G II, T&G IIR), ThermalStar GPS T&G II, and ThermalStar LCI and ThermalStar LWI Laminated Insulation boards intended for use on walls required to be of noncombustible construction are also identified along one edge, and on the face of one board in each bundle, with the name of the exterior coating company and the company's respective ICC-ES evaluation report number.

4. ThermalStar EIFS insulation boards are individually identified by a marking appearing on the edge of each insulation board, and on both faces of one board in each bundle, identifying the product type, the manufacturing plant designation, and the ICC-ES evaluation report number (ESR-1962).
5. The ThermalStar polyethylene tape is identified with the product name and the ICC-ES evaluation report number (ESR-1962).
6. Insulation boards used for installations in attics and crawl spaces as described in Section 4.2.2 must be identified as being produced from Styropek, EPSilyte, Nova, or Styrochem beads.

7.2 The report holder's contact information is the following:

**ATLAS MOLDED PRODUCTS, A DIVISION OF
ATLAS ROOFING CORPORATION
8240 BYRON CENTER SOUTHWEST
BYRON CENTER, MICHIGAN 49315
(800) 917-9138**

www.atlaseps.com

www.atlasmoldedproducts.com

TABLE 1—PRODUCT NAMES AND APPLICABLE USES

PRODUCT NAMES	SURFACE BURNING PERFORMANCE	THERMAL PERFORMANCE (R-VALUE)	ATTIC & CRAWL SPACE WITHOUT AN IGNITION BARRIER		ROOFING APPLICATIONS WITHOUT A THERMAL BARRIER	TERMITE RESISTANCE	WATER RESISTIVE BARRIER
ThermalStar T&G, ThermalStar Inter-Grade Board EPS, ThermalStar EIFS Board	✓	✓	✓		—	—	—
ThermalStar GPS T&G II	✓	✓	—		—	—	—
Atlas OEM, ThermalStar, DuraTherm, and Atlas Geofoam Expanded Polystyrene	✓	✓	✓		—	—	—
ThermalStar Taper, ThermalStar Insulation Board, ThermalStar Flute Fill	✓	✓	—		✓	—	—
TalonGuard Treated EPS	✓	✓	✓		—	✓	—
ThermalStar LCi, ThermalStar LRI, ThermalStar SWi, ThermalStar LWi Laminated Board	✓	✓	✓		—	—	✓

TABLE 2—MINIMUM R-VALUE (°F ft² h/Btu) AT 75°F MEAN TEMPERATURE

PROPERTY	TYPE I, T&G I, EIFS, INSULATION BOARD (TYPE I), THERMALSTAR FLUTE FILL, INTER-GRADE BOARD EPS, THERMALSTAR LCi, THERMALSTAR LRI, THERMALSTAR SWi, AND THERMALSTAR LWi LAMINATED INSULATION	TYPE VIII, INSULATION BOARD (TYPE VIII), TAPER, FLUTE FILL, THERMSTAR LCi, THERMALSTAR LRI, THERMALSTAR SWi, AND THERMALSTAR LWi LAMINATED INSULATION	ThermalStar TYPE II, T&G II, T&G IIR, ThermalStar GPS T&G II, INSULATION BOARD, TAPER, FLUTE FILL (TYPE II), THERMSTAR LCi, THERMALSTAR LRI, THERMALSTAR SWi, AND THERMALSTAR LWi LAMINATED INSULATION	TYPE IX, INSULATION BOARD, TAPER, FLUTE FILL (TYPE IX), THERMSTAR LCi, THERMALSTAR LRI, THERMALSTAR SWi, AND THERMALSTAR LWi LAMINATED INSULATION	TYPE XIV
Density, min., lb/ft³ (kg/m³)	0.90 (14.4)	1.15 (18.4)	1.35 (21.6)	1.80 (28.8)	2.40 (38.4)
Thermal resistance value, Per inch of thickness at 75°F. °F ft² h/Btu (°K m²/W)	3.60 (0.63)	3.80 (0.67)	4.00 (0.70)	4.20 (0.74)	4.20 (0.74)

For SI: 1 lb/ft³ = 16.018 kg/m³, 1°F ft² h/Btu = 0.176°K m²/W, 1inch = 25.4 mm.

TABLE 3—PHYSICAL PROPERTIES OF THERMALSTAR LCi, THERMSTAR SWi, THERMALSTAR LWi EPS BOARDS

PROPERTY	THERMALSTAR LCi, THERMALSTAR LCi, THERMALSTAR SWi, THERMALSTAR LWi LAMINATED INSULATION
Minimum density, lb/ft³ (kg/m³)	0.9 (14.4)
Compressive strength @ 10% def., psi (kPa)	10 (69)
Flexural strength, psi (kPa)	38.9 (268)

For SI: 1 lb/ft³ = 16.018 kg/m³, 1°F ft² h/Btu = 0.176°K m²/W, 1 psi = 6.895 kPa.

TABLE 4—POTENTIAL HEAT OF INSULATION BOARD

C578 TYPE ATLAS EPS	HEAT POTENTIAL (ENGLISH)	HEAT POTENTIAL (METRIC)
I	1500 Btu/ft²	17.0 mJ/m²
VIII	1875 Btu/ft²	21.3 mJ/m²
II	2250 Btu/ft²	25.5 mJ/m²
IX	3000 Btu/ft²	34.0 mJ/m²

TABLE 5 – PLANT LOCATIONS AND ID

MANUFACTURER NAME	ADDRESS	PLANT ID
ATLAS MOLDED PRODUCTS	8240 Byron Center Ave SW, Byron Center, MI 49315	EGRMI
ATLAS MOLDED PRODUCTS	90 Trowbridge Drive, Fond du Lac, WI 54936	EFDWI
ATLAS MOLDED PRODUCTS	445 Industrial Park Drive, Ridgeway, VA 24148	EMVVA
ATLAS MOLDED PRODUCTS	2731 White Sulfur Road, Gainesville, GA 30501	EGAGA
ATLAS MOLDED PRODUCTS	1400 North 3 rd Street, Kansas City, KS 66101	EKCBL
ATLAS MOLDED PRODUCTS	911 Industrial Drive, Perryville, MO 63775	EPVMO
ATLAS MOLDED PRODUCTS	111 West Fireclay Avenue, Murray, UT 84107	EMUUT
ATLAS MOLDED PRODUCTS	5250 North Sherman Street, Denver, CO 80216	EDNCO
ATLAS MOLDED PRODUCTS	Privada Misiones 1108, Tijuana, Mexico CP22500	ELACA
ATLAS MOLDED PRODUCTS	809 East 15 th Street, Washington, IA 52353	EWAI A
ATLAS MOLDED PRODUCTS	13695 Mt. Anderson Street, Reno, NV 89506	ERNNV
ATLAS MOLDED PRODUCTS	4555 N. Olympic Way, Kingman, AZ 86401	EKMAZ
ATLAS MOLDED PRODUCTS	3220 Avenue F, Arlington, TX 76011	EARTX



ICC-ES Evaluation Report

ESR-1962 CBC, CRC and CEC Supplement

Reissued July 2023

Revised October 2023

This report is subject to renewal July 2025.

www.icc-es.org | (800) 423-6587 | (562) 699-0543

A Subsidiary of the International Code Council®

DIVISION: 07 00 00—THERMAL AND MOISTURE PROTECTION

Section: 07 21 00—Thermal Insulation

Section: 07 22 00—Roof and Deck Insulation

Section: 07 25 00—Water-Resistive Barriers/Weather

REPORT HOLDER:

ATLAS MOLDED PRODUCTS, A DIVISION OF ATLAS ROOFING CORPORATION

EVALUATION SUBJECT:

ATLAS OEM, THERMALSTAR®, DURATHERM, ATLAS GEOFOAM, THERMALSTAR INSULATION BOARD, THERMALSTAR T&G BOARD (T&G, T&G II, T&G IIR), THERMALSTAR GPS T&G II, THERMALSTAR INTER-GRADE BOARD EPS, TALONGUARD TREATED EPS, THERMALSTAR EIFS, THERMALSTAR TAPER, THERMALSTAR FLUTE FILL AND THERMALSTAR L_{Ci}, THERMALSTAR L_{Wi}, THERMALSTAR L_{Ri}, THERMALSTAR S_{Wi} LAMINATED INSULATION BOARD

1.0 REPORT PURPOSE AND SCOPE

Purpose:

The purpose of this evaluation report supplement is to indicate that Expanded Polystyrene (EPS), described in ICC-ES evaluation report ESR-1962, have also been evaluated for compliance with the codes noted below.

Applicable code edition(s):

- 2019 *California Building Code*® (CBC)

For evaluation of applicable chapters adopted by the California Office of Statewide Health Planning and Development (OSHPD) AKA: California Department of Health Care Access and Information (HCAI) and the Division of State Architect (DSA), see Sections 2.1.1 and 2.1.2 below.

- 2019 *California Residential Code*® (CRC)
- 2019 *California Energy Code*® (CEC)

2.0 CONCLUSIONS

2.1 CBC:

The Expanded Polystyrene (EPS), described in Sections 2.0 through 7.0 of the evaluation report ESR-1962, comply with the 2019 CBC, provided the design and installation are in accordance with the 2018 *International Building Code*® (IBC) provisions noted in the evaluation report.

2.1.1 OSHPD:

The applicable OSHPD Sections and Chapters of the CBC are beyond the scope of this supplement

2.1.2 DSA:

The applicable DSA Sections and Chapters of the CBC are beyond the scope of this supplement.

2.2 CRC:

The Expanded Polystyrene (EPS), described in Sections 2.0 through 7.0 of the evaluation report ESR-1962, comply with the 2019 CRC, provided the design and installation are in accordance with the 2018 *International Residential Code*® (IRC) provisions noted in the evaluation report.

ICC-ES Evaluation Reports are not to be construed as representing aesthetics or any other attributes not specifically addressed, nor are they to be construed as an endorsement of the subject of the report or a recommendation for its use. There is no warranty by ICC Evaluation Service, LLC, express or implied, as to any finding or other matter in this report, or as to any product covered by the report.



2.3 CEC:

The Expanded Polystyrene (EPS), described in Sections 2.0 through 7.0 of the evaluation report ESR-1962, comply with the 2019 CEC, provided the design and installation are in accordance with the 2018 *International Building Code*[®] (IBC) provisions noted in the evaluation report.

2.3.1 Conditions of Use:

In accordance with Section 110.8 of the 2019 California Energy Code (CEC), verification of certification by the Department of Consumer Affairs, Bureau of Household Goods and Services, must be provided to the code official, demonstrating that the insulation conductive thermal performance is approved pursuant to the California Code of Regulations, Title 24, Part 12, Chapters 12-13, Article 3, "Standards for Insulating Materials." The certification must be verified with the DCA Bureau of Household Goods and Services using the following link to the bureau's Directory of Certified Insulation Materials: https://bhgs.dca.ca.gov/consumers/ti_directory.pdf

This supplement expires concurrently with the evaluation report, reissued July 2023 and revised October 2023.



Boxabl

Test Report

Single Hung Window Installed in Structural Insulated Panel, Structural Loading and Air Infiltration

Prepared for:

Boxabl
5345 N Belt Road
Las Vegas, NV 89115

Original Issue Date: 1/24/2024
Revision 1
Project Number: 236115.R

Issue Date: 1/24/2024
 Revised Issue Date: 1/31/2024
 Project No. 236115.R

5345 N Belt Road
 Las Vegas, NV 89115

Subject: Single Hung Window Installed into SIP Panel, Structural Loading and Air Infiltration, per ASTM E330/E330M-14(R21) ASTM E283/E283M-19, AAMA101/I.S.2/A440-17, NAFS 2017

Dear Mr. Denman,

In accordance with your request and authorization, we are presenting the results of our findings. We appreciate the opportunity to be of service on this project. Should you have any questions regarding this report or if we can be of further service, please do not hesitate to contact the undersigned.

Respectfully submitted,
TWINING CONSULTING Inc. dba Radco

Tested by:		Submitted by:	
Tomas Burokas Test Technician	<i>Tomas Burokas</i>	Andrew Falkenburg Laboratory Director	

Table of Contents

1.0 INTRODUCTION	4
2.0 REFERENCED TEST METHODS	4
3.0 TEST SPECIMEN DESCRIPTION	4
4.0 SAMPLING PROCEDURES	4
5.0 TEST EQUIPMENT	5
6.0 ASTM E330/E330M PROCEDURE A	5
7.0 ASTM E283/E283M PROCEDURE	6
8.0 TEST RESULTS	6
9.0 CONFORMITY TABLE	7
10.0 REVISION LOG	7
11.0 PHOTOGRAPHS	8
Appendix A: Bonded Window Installation WI-ASY-011	11
Appendix B: SIP-SEAL® Adhesive Sealant Technical Data Sheet	14

1.0 INTRODUCTION

At the request of Boxabl, Twining Consulting Inc. dba Radco conducted the test listed below in section 2.0 on one (1) single hung window that was installed in a Structurally Insulated Panel (SIP) by Boxabl personnel. The test specimen was tested in accordance with the referenced test methods outlined in section 2.0. The specimen was tested on January 18, 2024.

2.0 REFERENCED TEST METHODS

AAMA/WDMA/CSA 101/I.S.2/A440-17, NAFS 2017 – “North American Fenestration Standard/Specification for Windows, Doors, and Skylights”

ASTM E330/330M-14 (R21) Procedure A, “Standard Test Method for Structural Performance of Exterior Windows, Doors, Skylights and Curtain Walls by Uniform Static Air Pressure Difference”

ASTM E283/E283M-19, “Determining Rate of Air Leakage Through Exterior Windows, Curtain Walls, and Doors Under Specified Pressure Differences Across the Specimen”

3.0 TEST SPECIMEN DESCRIPTION

The following description and table is information provided by the client:

The test specimen is a JELD-WEN Single hung builders’ vinyl (white), full unit, side load, flush fin, no ventilator, low-E 366 CLR, Arg 0 - 3500 feet standard thickness screen with standard screen fiberglass mesh equipped with two cam-locks, installed into a SIP measuring 7’ ft. W x 8 ft. H. x 6 in. thick, built to panel listing ESR 4725 using SIP Seal® Adhesive Sealant (Appendix B) around the perimeter of the window fin. The panel was produced, and the window installed by Boxabl in their Las Vegas, Nevada facility. The specimen installation process is referenced in Appendix A.

Table 1: Window Details (client provided)

MODEL	CONFIGURATION	MATERIAL	TOTAL SIZE	U-FACTOR	SOLAR HEAT GAIN
Builder	Single Hung	Vinyl	74.75 in H x 38.75 in. W	0.25	0.21

4.0 SAMPLING PROCEDURES

The test specimen window installation was witnessed virtually by Twining Consulting Personnel on December 28, 2023. Boxabl personnel selected the window and SIP and proceeded to install per work instruction Bonded Window Installation WI-ASY-011 (Appendix A).

5.0 TEST EQUIPMENT

Table 2: Test Equipment Used

CATEGORY	TYPE	MANUFACTURER	MODEL #	SERIAL #	ID #
Pressure	Pressure Transducer	Setra	265	8473301	54
Time	Stopwatch	Control Co.	1051	160257320	2039
Airflow	Laminar Flow Element	Meriam	100	1644000087	54
Temp/RH/Pressure	Weather Station	Taylor	V0644	4008	4008
Dimensional	String Potentiometers	UniMeasure	12 in.	4046, 4047, 4048	4046, 4047, 4048

6.0 ASTM E330/E330M PROCEDURE A

“Standard Test Method for Structural Performance of Exterior Windows, Doors, Skylights and Curtain Walls by Uniform Static Air Pressure Difference”

Uniform Load Deflection

The test was conducted in accordance with ASTM E330 procedure A. The specimen was installed into a dimensional lumber frame and mounted to the test fixture and sealed for airtightness. A positive preload was applied using a regenerative blower. The load was then released, and the deflection transducers were set to zero. A positive load was then applied and held for 10 seconds during which the deflection measurements were recorded. The panel was allowed a recovery period of 60 seconds, after which the pressure was reversed and negative pressure equal to that of the positive pressure was applied in the same method. After loading was complete, the specimen was examined for permanent damage and normal operation.

Uniform Structural Load

The test was conducted in the same manner as “*Uniform Load Deflection*” procedure except the structural load pressures were applied. Deflections were measured at the mainframe, sash, and corners. After loading, a permanent set of the greatest span was recorded and the specimen was evaluated for permanent damage to hardware parts, actuating mechanisms, disengagement of the sash, mainframe or glazing and any other damage that would render the specimen to be inoperable.

7.0 ASTM E283/E283M PROCEDURE

“Standard Test Method for Determining Rate of Air Leakage Through Exterior Windows, Skylights, Curtain Walls, and Doors Under Specified Pressure Differences Across the Specimen.”

A sheet of vinyl was applied to the window system from the exterior to seal and measure the leakage of the chamber (Q_e). A regenerative blower was used to create a positive chamber pressure of 1.57 psf (0.3 IWC) on the interior of the UUT. This pressure differential was held until stabilized, and the airflow required to maintain this pressure was recorded. After, the exterior sheet was removed and the positive pressure of 1.57 psf (0.3 IWC) was developed. The pressure differential was held until stabilized, and the airflow required to maintain this pressure was recorded as total leakage rate (Q_t). The airflow rates were corrected to standard conditions as prescribed in ASTM E283. The leakage rate through the specimen is expressed as follows: $Q_s = Q_t - Q_e$. Rate of air leakage per unit area is also expressed as follows: $q_A = Q_s/A$.

8.0 TEST RESULTS

Table 3: Test results for single hung window installed in SIP panel

TEST TITLE	RESULTS	ALLOWABLE	NOTE
Uniform Load Maximum Deflection, Per ASTM E330 +2159.40 Pa (+45.1 psf) -2159.40 Pa (-45.1 psf)	Corner: 7.11 mm (0.28 in.) Center Span: 10.41 mm (0.41 in.)	Report Only	2
Uniform Structural Load, Per ASTM E330 +3241.49 Pa (+67.7 psf) -3241.49 Pa (-67.7 psf)	2.79 mm (0.11 in.) 2.54 mm (0.10 in.)	9.8mm (0.386 in.) 9.8mm (0.386 in.)	2, 3
Air Leakage, Infiltration per ASTM E283 at 75 Pa (1.57 psf)	<1.5 L/s/m ² (0.11cfm/ft ²) PASS	1.5 L/s/m ² (0.30 cfm/ft ²)	1
Air Leakage, Exfiltration per ASTM E283 at 75 Pa (1.57 psf)	<1.5 L/s/m ² (0.07cfm/ft ²) PASS	1.5 L/s/m ² (0.30 cfm/ft ²)	1
Water Penetration, Per ASTM E331	NOT TESTED	N/A	N/A

Note 1: The tested specimen meets (or exceeds) the performance levels specified in AAMA/WDMA/CSA 101/I.S.2/A440-17 for Air Leakage resistance.

Note 2: Testing loads were held for 10 seconds and allowed a rest period of 60 seconds before an assessment was made.

Note 3: Structural Requirement - There shall be no glass breakage, or any condition with would cause the specimen to be inoperable.

9.0 CONFORMITY TABLE

REPORT SECTION	FINDINGS/RESULTS	CONFORMITY STATEMENT	APPLICABLE STANDARD	DECISION RULE APPLIED
8.0	<1.5 L/s/m ² (0.11cfm/ft ²)	PASS	ASTM E283/E283M-19,	Simple Acceptance

10.0 REVISION LOG

REVISION NUMBER	DATE	PAGE(S)	REVISION
1	1/31/24	3, 4, 14, 15, 16	Updated table of contents to include Appendix B, included SIP-Seal® Adhesive Sealent in specimen description, added Appendix B with SIP-Seal Technical Data Sheet.

11.0 PHOTOGRAPHS



Photo 1: ASTM E283 Tare



Photo 2: ASTM E283 Total Leakage Measurement



Photo 3: Uniform Load Deflection Measurement



Photo 4: Structural Loading, per ASTM E330

*******END REPORT*******

Appendix B: SIP-SEAL® Adhesive Sealant Technical Data Sheet

SIP-SEAL®
THE BEST STUFF FOR THE JOB

ADHESIVE SEALANT

TECHNICAL DATA SHEET



Product Description

- Industrial grade, highly durable polyether construction adhesive/sealant
- Ready to use, cures in the presence of moisture
- Will not harden, yellow, or lose its flexibility
- Weather resistant, Type II for extended water contact
- Paintable
- Smooth gunning, workable in low temperatures

Applications

- Joint sealant, subfloor and general adhesion
- Door and window sealant
- Indoor/outdoor use
- Adheres to OSB, wood, EPS foam, concrete, ceramics, metal, vinyl, PVC plastic, phenolic panels, ABS insulation and most other non-asphaltic substrates. (Always check adhesion).

Package/Colors

- 20-oz sausage pack: Bright White (61011), Gray (61010)
- 20 count per case
- 45 cases per pallet

Technical Data

- Specific gravity 1.4-1.5
- Tack-free time 60 mins (77°F, 50% rh)
- Skin Time 30 mins (77°F, 50% rh)
- Non-sagging
- Tensile strength 225 psi
- Lap shear 275 psi
- Elongation 275%
- Hardness Shore A 45-50
- High-temp resistance 300°F for brief periods
- Low-temp flexibility -75°F
- Non-corrosive, non-staining

Environmental

- Intertek Gold Certified - No hazardous air pollutants (HAPS-free)
- 99% solids, no solvents
- No isocyanates
- Low VOC, less than 12-grams/liter
- Shelf life of 18-months from indicated date of manufacture when stored below 80°F. Will not freeze

Engineering Standards

- Meets or exceeds ASTM C920, Type S, Grade NS, Class 25. Use T, NT, G, I and A
- Complies with American Architectural Manufacturers Assoc. 802.3 Type II Back Bedding Compound
- UV stability ASTM G26
- USDA approved

Usage Instructions

- For best results, apply to clean, dry, frost-free surfaces to ensure proper seal
- Apply in continuous beads in accordance with SIP manufacturer's manual
- Application temperature of 0°F to 120°F.
- Always check adhesion
- Paintable after cure, always test to ensure suitability.
- Use with adequate ventilation inhalation of vapor during application and cure may cause slight eye and throat irritation
- In case of contact with eyes, lips, or mouth flush thoroughly with water. If irritation persists, consult a physician
- Avoid repeated, prolonged contact to skin
- Refer to SDS for additional warnings and instructions

Limited Warranty

Products are free from manufacturing defects and when used according to the manufacturer's published specifications will meet the manufacturer's published performance standards for a period of ten years from the date of shipment from the factory. Sstant will, at its sole option, replace the defective product or refund the purchase price paid by the user with acceptable proof of purchase from an authorized seller. There are no other warranties, express or implied, including but not limited to any implied warranties of merchantability or fitness for a particular purpose. The user is responsible for determining the suitability of the product for the user's needs. Neither Sstant nor its manufacturers shall have a liability for any other damages, including but not limited to any indirect, special, or consequential damages, even if they have been advised of the possibility of such.

For More Info:

SIPSEAL.COM | INFO@SIPSEAL.COM | (651) 300-0505

Made in USA



Rev: 01-14-2021



July 25, 2023

Subject: Boxabl Installation Method

Boxabl:

JELD-WEN vinyl flush fin windows (Single Hung and Fixed) were recently tested in a Boxabl wall installed per Boxabl install method on attached WI-ASY-011. The installation method passed all testing per NAFS 17 / ASTM E330 / ASTM E547 as required by the Building/Residential building code for fenestration up to PG35/DP+/-35. There are no concerns with the Boxabl installation method performing as required at these mentioned pressures and water infiltration levels.

If you have any further questions, please don't hesitate to reach out to me.

Regards,

A handwritten signature in blue ink, appearing to read 'Jason Kantola'.

Jason Kantola
NA Leader Sustainability and Certification

jkantola@jeldwen.com

541-591-1157

Work Instructions

BXB-000012 CZ1	Description:	Bonded Window Installation	57 of 115
	WI #:	WI-ASY-011	
	Owner:	Q. Regan	



This work instruction outlines the window installation process using the adhesive bonding method.



1. Prepare for installation by placing the window on a rolling cart and positioning the cart in front of the window opening.



2. Dry fit the window into the window opening. Remove any excess glue, lumber, foam or steel in the window opening to ensure a proper and flush fit. Once you have a proper dry fit, place the window back onto the rolling cart.



3. Clean the inside edge of the window frame using the 2 cloth cleaning method.

First wipe with a damp cloth of clean water or 70% isopropyl alcohol. Then wipe with a dry cloth.

Work Instructions

BXB-000012 CZ1	Description:	Bonded Window Installation	58 of 115
	WI #:	WI-ASY-011	
	Owner:	Q. Regan	



4. Clean the area around the window opening using the same 2 cloth cleaning method.



5. Apply Sip Seal adhesive in a uniform 1/4" – 3/8" bead using a battery powered, barrel sausage caulking gun.

Apply a continuous and uniform bead approximately 1 inch from the edge of the window frame being careful not to leave any voids in the bead.



6. With the help of another team member place the bottom edge of the mirror in the window opening and carefully mount the window. Apply even pressure to engage the sip seal and secure the window to the opening.

Work Instructions

BXB-000012 CZ1	Description:	Bonded Window Installation	59 of 115
	WI #:	WI-ASY-011	
	Owner:	Q. Regan	

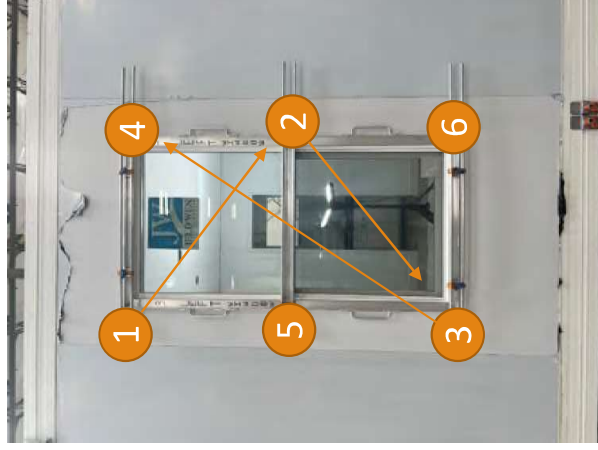

7. With 1 team member on the ground and 1 team member on a ladder place the window installation fixture onto the window frame.

Activate the suction cups by pressing the built in vacuum pump buttons.

8. In an alternating star pattern fully engage the suction cups by pressing the built-in vacuum pumps until you no longer feel pump resistance.

Refer to the diagram above and pump from 1 to 2 to 3 and so on until you reach 6.

8. After each suction cup has been activated go backwards and re-pump in reverse order from position 6 to 1 as the suction cups will have adjusted. When you are done, each suction cup will have been fully pumped twice.



Work Instructions

BXB-000012 CZ1	Description:	Bonded Window Installation	60 of 115
	WI #:	WI-ASY-011	
	Owner:	Q.Regan	



REV	Description of changes	Changed by:
A	Initial Release	Q.Regan



South Central Regional Construction Code Council

5058 W. Main Street Houma, Louisiana 70360

P.O. Box 1870, Gray, Louisiana 70359

Toll Free at 1-866-95-PERMIT or (985) 655-1070

MyPermitNow.Org

The following chart is provided to clarify the DP rating requirements for each design wind speed per the International Residential Code and the Guidelines for Hurricane Resistant Residential Construction.

DP Rating For Design Wind Speeds

(based on 2006 IRC - Table R301.2(2) & 2005 Hurricane Guide - Table 602A)

Center of Wall								
Window opening area (sf)	90mph	100mph	110mph	120mph	130mph	140mph	150mph	170mph
10	DP-20	DP-20	DP-25	DP-30	DP-35	DP-40	DP-45	DP-60
20	DP-20	DP-20	DP-25	DP-30	DP-35	DP-40	DP-45	DP-55
50	DP-20	DP-20	DP-25	DP-30	DP-30	DP-35	DP-40	DP-55
100	DP-20	DP-20	DP-25	DP-25	DP-30	DP-35	DP-40	DP-50
500	DP-20	DP-20	DP-20	DP-25	DP-30	DP-30	DP-35	DP-45

Corner of wall (windows located within 4 feet of corner)								
Window opening area (sf)	90mph	100mph	110mph	120mph	130mph	140mph	150mph	170mph
10	DP-20	DP-25	DP-30	DP-35	DP-45	DP-50	DP-55	DP-70
20	DP-20	DP-25	DP-30	DP-35	DP-40	DP-45	DP-55	DP-65
50	DP-20	DP-25	DP-25	DP-30	DP-35	DP-40	DP-50	DP-60
100	DP-20	DP-20	DP-25	DP-30	DP-35	DP-40	DP-45	DP-55
500	DP-20	DP-20	DP-20	DP-25	DP-30	DP-30	DP-35	DP-45

NOTE: 7/16 inch plywood is only an exception for replacing the requirement for Large Missile tested glazing. It DOES NOT substitute the DP rating requirement. R303.2.1.2

Windows shall meet the requirements of climate zone 2 on Table N1102.1 of the IRC as follows:

Fenestration (*U-Factor*: 0.75 or less)

Glazed Fenestration (SHGC: 0.40 or less)

Pat Gordon
Chairman
Terrebonne

Jody Chenier
Vice-Chairman
St. James

Lou Vaughn
St. John

John Boudreaux
Assumption

Deborah K. Moore
Lafourche

Kevin Belanger
SCPDC



Builders™ Vinyl (V-2500™)

The performance information listed is for new products and is intended to be used for reference only, and is not complete. Depending on the components, accessories, and options chosen, the actual rating could vary. Confirm ratings for specific products with supplier or JELD-WEN sales representative.

PRODUCT	GLAZING	No Grid				Qualifies for Energy Star				Flat or Contour Grids			Qualifies for Energy Star				
		U-Factor	SHGC	VT	CR	N	NC	SC	S	U-Factor	SHGC	VT	N	NC	SC	S	
Double Hung PG 20	Clear	0.48	0.59	0.62	42					0.48	0.53	0.55					
	SunStable™	0.34	0.32	0.54	51					0.34	0.29	0.48					
	SunStable™ Argon	0.31	0.32	0.54	54					0.31	0.29	0.48					
	SunStable™ with HeatSave™	0.29	0.28	0.52	35	X	X			0.29	0.25	0.46	X	X			
	SunStable™ with HeatSave™ Argon	0.26	0.31	0.54	45	X	X			0.26	0.28	0.48	X	X			
	SunResist™	0.34	0.21	0.49	52				X	0.34	0.19	0.43					X
	SunResist™ Argon	0.30	0.21	0.49	55		X	X	X	0.30	0.19	0.43		X	X	X	X
	SunResist™ with HeatSave™	0.29	0.21	0.48	41		X	X	X	0.29	0.19	0.42		X	X	X	X
	SunResist™ with HeatSave™ Argon	0.26	0.21	0.48	45	X	X	X	X	0.26	0.19	0.43	X	X	X	X	X
	SunFlow™	0.35	0.50	0.60	53					0.35	0.45	0.54					
	SunFlow™ Argon	0.31	0.50	0.60	56					0.31	0.45	0.54					
	SunFlow™ with HeatSave™	0.29	0.47	0.58	40	X				0.29	0.42	0.52	X				
	SunFlow™ with HeatSave™ Argon	0.27	0.48	0.59	44	X				0.27	0.43	0.44	X				
	Energy Saver	0.31	0.32	0.54	54					0.31	0.29	0.48					
	Energy Saver Plus	0.30	0.21	0.49	55		X	X	X	0.30	0.19	0.43		X	X	X	X
	ENERGY STAR® Northern	0.30	0.50	0.60	44	X				0.27	0.43	0.52	X				
	ENERGY STAR® North Central	0.30	0.32	0.55	59		X			0.30	0.29	0.49		X			
	ENERGY STAR® South Central	0.30	0.21	0.49	55		X	X	X	0.30	0.19	0.43		X	X	X	X
	ENERGY STAR® Southern	0.34	0.21	0.49	52				X	0.34	0.19	0.43					X
	Double Hung PG 35/50	Clear	0.48	0.60	0.63	43					0.48	0.54	0.56				
SunStable™		0.34	0.32	0.54	51					0.34	0.29	0.48					
SunStable™ Argon		0.31	0.32	0.54	54					0.31	0.29	0.48					
SunStable™ with HeatSave™		0.29	0.28	0.52	35		X			0.29	0.25	0.46		X			
SunStable™ with HeatSave™ Argon		0.27	0.31	0.54	44	X	X			0.27	0.28	0.48	X	X			
SunResist™		0.34	0.21	0.49	52				X	0.34	0.19	0.43					X
SunResist™ Argon		0.31	0.21	0.49	54				X	0.31	0.19	0.43					X
SunResist™ with HeatSave™		0.29	0.21	0.48	41		X	X	X	0.29	0.19	0.42		X	X	X	X
SunResist™ with HeatSave™ Argon		0.26	0.21	0.48	45	X	X	X	X	0.26	0.19	0.43	X	X	X	X	X
SunFlow™		0.35	0.50	0.60	53					0.35	0.45	0.54					
SunFlow™ Argon		0.32	0.50	0.60	56					0.32	0.45	0.54					
SunFlow™ with HeatSave™		0.30	0.47	0.58	40	X				0.30	0.42	0.52	X				
SunFlow™ with HeatSave™ Argon		0.27	0.48	0.59	44	X				0.27	0.43	0.52	X				
Energy Saver		0.31	0.32	0.54	54					0.31	0.29	0.48					
Energy Saver Plus		0.30	0.21	0.49	58		X	X	X	0.30	0.19	0.44		X	X	X	X
ENERGY STAR® Northern		0.27	0.48	0.59	44	X				0.27	0.43	0.52	X				
ENERGY STAR® North Central		0.30	0.32	0.55	58		X			0.30	0.29	0.49		X			
ENERGY STAR® South Central		0.30	0.21	0.49	58		X	X	X	0.30	0.19	0.44		X	X	X	X
ENERGY STAR® Southern		0.34	0.21	0.49	52				X	0.34	0.19	0.43					X
Double Hung Fixed		Clear	0.47	0.67	0.71	42					0.47	0.61	0.64				
	SunStable™	0.31	0.36	0.62	52					0.31	0.33	0.56					
	SunStable™ Argon	0.27	0.36	0.62	54	X				0.27	0.33	0.56	X				
	SunStable™ with HeatSave™	0.25	0.32	0.59	35	X	X	X	X	0.25	0.29	0.53	X	X	X	X	X
	SunStable™ with HeatSave™ Argon	0.23	0.36	0.62	45	X	X			0.23	0.32	0.55	X	X			
	SunResist™	0.31	0.24	0.56	52				X	0.31	0.22	0.50					X
	SunResist™ Argon	0.27	0.24	0.56	54	X	X	X	X	0.27	0.22	0.50	X	X	X	X	X
	SunResist™ with HeatSave™	0.25	0.24	0.55	42	X	X	X	X	0.25	0.24	0.55	X	X	X	X	X
	SunResist™ with HeatSave™ Argon	0.22	0.23	0.55	45	X	X	X	X	0.22	0.21	0.50	X	X	X	X	X
	SunFlow™	0.32	0.57	0.69	53					0.32	0.52	0.62					
	SunFlow™ Argon	0.28	0.57	0.69	57	X				0.28	0.52	0.62	X				
	SunFlow™ with HeatSave™	0.26	0.54	0.67	41	X				0.26	0.49	0.60	X				
	SunFlow™ with HeatSave™ Argon	0.23	0.55	0.68	44	X				0.23	0.50	0.61	X				
	Energy Saver	0.27	0.36	0.62	54	X	X			0.27	0.33	0.56	X	X			
	Energy Saver Plus	0.27	0.24	0.56	54	X	X	X	X	0.27	0.22	0.50	X	X	X	X	X
	ENERGY STAR® Northern	0.28	0.57	0.69	57	X				0.28	0.52	0.62	X				
	ENERGY STAR® North Central	0.27	0.36	0.62	54	X	X			0.27	0.33	0.56	X	X			
	ENERGY STAR® South Central	0.27	0.24	0.56	54	X	X	X	X	0.27	0.22	0.50	X	X	X	X	X
	ENERGY STAR® Southern	0.31	0.24	0.56	52				X	0.31	0.22	0.50					X



Builders™ Vinyl (V-2500™)

The performance information listed is for new products and is intended to be used for reference only, and is not complete. Depending on the components, accessories, and options chosen, the actual rating could vary. Confirm ratings for specific products with supplier or JELD-WEN sales representative.

PRODUCT	GLAZING	No Grid				Qualifies for Energy Star				Flat or Contour Grids				Qualifies for Energy Star			
		U-Factor	SHGC	VT	CR	N	NC	SC	S	U-Factor	SHGC	VT	N	NC	SC	S	
Fixed	Clear	0.47	0.69	0.72	43					0.47	0.62	0.65					
	SunStable™	0.31	0.37	0.63	54					0.31	0.33	0.57					
	SunStable™ Argon	0.28	0.36	0.63	58	X	X			0.28	0.33	0.57	X	X			
	SunStable™ with HeatSave™	0.25	0.32	0.59	36					0.25	0.29	0.53	X	X			
	SunStable™ with HeatSave™ Argon	0.23	0.36	0.62	41	X	X			0.23	0.32	0.55	X	X			
	SunResist™	0.31	0.24	0.57	55				X	0.31	0.22	0.51					X
	SunResist™ Argon	0.27	0.24	0.57	58	X	X	X	X	0.27	0.22	0.51	X	X	X	X	X
	SunResist™ with HeatSave™	0.25	0.24	0.55	42					0.25	0.24	0.55	X	X	X	X	X
	SunResist™ with HeatSave™ Argon	0.22	0.23	0.55	45	X	X	X	X	0.22	0.21	0.50	X	X	X	X	X
	SunFlow™	0.32	0.57	0.69	51					0.32	0.52	0.62					
	SunFlow™ Argon	0.28	0.57	0.69	57	X				0.28	0.52	0.62	X				
	SunFlow™ with HeatSave™	0.26	0.54	0.67	41					0.26	0.49	0.60	X				
	SunFlow™ with HeatSave™ Argon	0.23	0.55	0.68	44	X				0.23	0.50	0.61	X				
	Energy Saver	0.28	0.36	0.63	58	X	X			0.28	0.33	0.57	X	X			
	Energy Saver Plus	0.27	0.24	0.57	58	X	X	X	X	0.27	0.22	0.51	X	X	X	X	X
	ENERGY STAR® Northern	0.28	0.57	0.69	57	X				0.28	0.52	0.62	X				
	ENERGY STAR® North Central	0.28	0.36	0.63	58	X	X			0.28	0.33	0.57	X	X			
	ENERGY STAR® South Central	0.27	0.24	0.57	58	X	X	X	X	0.27	0.22	0.51	X	X	X	X	X
	ENERGY STAR® Southern	0.33	0.24	0.57	55				X	0.33	0.22	0.51					X
	Horizontal Slider	Clear	0.48	0.66	0.69	44					0.48	0.60	0.62				
SunStable™		0.33	0.35	0.60	52					0.33	0.32	0.54					
SunStable™ Argon		0.30	0.35	0.60	55		X			0.30	0.32	0.54		X			
SunStable™ with HeatSave™		0.28	0.30	0.57	35	X	X			0.28	0.28	0.51		X	X		
SunStable™ with HeatSave™ Argon		0.25	0.34	0.59	40	X	X			0.25	0.31	0.53	X	X			
SunResist™		0.33	0.23	0.54	52				X	0.33	0.22	0.49					X
SunResist™ Argon		0.29	0.23	0.54	55		X	X	X	0.29	0.21	0.49		X	X	X	X
SunResist™ with HeatSave™		0.27	0.23	0.53	41	X	X	X	X	0.27	0.21	0.47	X	X	X	X	X
SunResist™ with HeatSave™ Argon		0.25	0.23	0.53	44	X	X	X	X	0.25	0.21	0.48	X	X	X	X	X
SunFlow™		0.34	0.55	0.67	49					0.34	0.49	0.60					
SunFlow™ Argon		0.31	0.55	0.67	54					0.31	0.49	0.60					
SunFlow™ with HeatSave™		0.28	0.52	0.64	40	X				0.28	0.47	0.58	X				
SunFlow™ with HeatSave™ Argon		0.26	0.53	0.65	43	X				0.26	0.48	0.58	X				
Energy Saver		0.30	0.35	0.60	55		X			0.30	0.32	0.54		X			
Energy Saver Plus		0.30	0.23	0.54	52		X	X	X	0.30	0.21	0.49		X	X	X	X
ENERGY STAR® Northern		0.30	0.55	0.67	54	X				0.30	0.49	0.60	X				
ENERGY STAR® North Central		0.30	0.35	0.60	52		X			0.30	0.32	0.54		X			
ENERGY STAR® South Central		0.30	0.23	0.54	52		X	X	X	0.30	0.21	0.49		X	X	X	X
ENERGY STAR® Southern		0.33	0.24	0.54	50				X	0.33	0.22	0.49					X
Side Load Single Hung		Clear	0.48	0.66	0.69	43					0.48	0.60	0.62				
	SunStable™	0.33	0.35	0.61	51					0.33	0.32	0.54					
	SunStable™ Argon	0.30	0.35	0.61	54		X			0.30	0.32	0.54		X			
	SunStable™ with HeatSave™	0.28	0.30	0.57	40		X			0.28	0.28	0.51		X			
	SunStable™ with HeatSave™ Argon	0.25	0.34	0.59	39	X	X			0.25	0.31	0.53	X	X			
	SunResist™	0.33	0.23	0.54	52				X	0.33	0.21	0.49					X
	SunResist™ Argon	0.29	0.23	0.54	55		X	X	X	0.29	0.21	0.49		X	X	X	X
	SunResist™ with HeatSave™	0.27	0.23	0.53	40	X	X	X	X	0.27	0.21	0.47	X	X	X	X	X
	SunResist™ with HeatSave™ Argon	0.25	0.23	0.53	44	X	X	X	X	0.25	0.21	0.48	X	X	X	X	X
	SunFlow™	0.34	0.55	0.67	47					0.34	0.50	0.60					
	SunFlow™ Argon	0.30	0.55	0.67	54	X				0.30	0.49	0.60	X				
	SunFlow™ with HeatSave™	0.28	0.52	0.64	39	X				0.28	0.47	0.57	X				
	SunFlow™ with HeatSave™ Argon	0.26	0.53	0.65	43	X				0.26	0.48	0.58	X				
	Energy Saver	0.30	0.35	0.61	54		X			0.30	0.32	0.54		X			
	Energy Saver Plus	0.29	0.23	0.54	55		X	X	X	0.29	0.21	0.49		X	X	X	X
	ENERGY STAR® Northern	0.30	0.55	0.67	54	X				0.30	0.49	0.60	X				
	ENERGY STAR® North Central	0.30	0.35	0.61	54		X			0.30	0.32	0.54		X			
	ENERGY STAR® South Central	0.29	0.23	0.54	55		X	X	X	0.29	0.21	0.49		X	X	X	X
	ENERGY STAR® Southern	0.33	0.23	0.54	52				X	0.33	0.21	0.49					X
	Sidelite or Transom	Clear	0.46	0.61	0.63	43					0.46	0.54	0.56				
SunStable™		0.33	0.32	0.55	55					0.33	0.29	0.49					
SunStable™ Argon		0.30	0.32	0.55	58	X	X			0.30	0.29	0.49	X	X			
SunStable™ with HeatSave™		0.23	0.34	0.59	0.45	X	X			0.23	0.31	0.52	X	X			
SunStable™ with HeatSave™ Argon		0.23	0.34	0.59	0.45	X	X			0.23	0.31	0.52	X	X			
SunResist™		0.27	0.23	0.54	0.57	X	X	X	X	0.27	0.21	0.48	X	X	X	X	X
SunResist™ Argon		0.29	0.21	0.50	59	X	X	X	X	0.29	0.19	0.44	X	X	X	X	X
SunResist™ with HeatSave™		0.23	0.22	0.53	45	X	X	X	X	0.23	0.20	0.47	X	X	X	X	X
SunResist™ with HeatSave™ Argon		0.24	0.23	0.54	44	X	X	X	X	0.24	0.20	0.47	X	X	X	X	X
SunFlow™		0.34	0.55	0.67	47					0.34	0.50	0.60					
SunFlow™ Argon		0.30	0.55	0.67	54	X				0.30	0.49	0.60	X				
SunFlow™ with HeatSave™		0.28	0.52	0.64	39	X				0.28	0.47	0.57	X				
SunFlow™ with HeatSave™ Argon		0.26	0.53	0.65	43	X				0.26	0.48	0.58	X				
Energy Saver		0.30	0.35	0.61	54		X			0.30	0.32	0.54		X			
Energy Saver Plus		0.29	0.21	0.50	59	X	X	X	X	0.29	0.19	0.44	X	X	X	X	X
ENERGY STAR® Northern		0.30	0.32	0.55	58	X	X			0.30	0.29	0.49	X	X			
ENERGY STAR® North Central		0.30	0.32	0.55	58	X	X			0.30	0.29	0.49	X	X			
ENERGY STAR® South Central		0.29	0.21	0.50	59			X	X	0.29	0.19	0.44		X	X	X	X
ENERGY STAR® Southern		0.29	0.21	0.50	59			X	X	0.29	0.19	0.44		X	X	X	X
Sliding Patio Door		Clear	0.47	0.65	0.68	42					0.47	0.57	0.60				
	SunStable™	0.32	0.35	0.60	52					0.32	0.31	0.52					
	SunStable™ Argon	0.29	0.35	0.60	55	X	X			0.29	0.31	0.52	X	X			
	SunStable™ with HeatSave™	0.26	0.30	0.57	36	X	X			0.26	0.27	0.50	X	X			
	SunStable™ with HeatSave™ Argon	0.24	0.34	0.58	43	X	X			0.24	0.30	0.51	X	X			
	SunResist™	0.32	0.23	0.54	52					0.32	0.21	0.47					
	SunResist™ Argon	0.28	0.23	0.54	55	X	X	X	X	0.28	0.20	0.47	X	X	X	X	X
	SunStable™, Internal Blinds	0.35	0.31	0.58	46					-	-	-					
	SunResist™ with HeatSave™	0.26	0.23	0.53	41	X	X	X	X	0.26	0.20	0.46	X	X	X	X	X
	SunResist™ with HeatSave™ Argon	0.24	0.22	0.52	44	X	X	X	X	0.24	0.20	0.46	X	X	X	X	X
	SunFlow™ with HeatSave™	0.25	0.52	0.64	43	X				0.25	0.46	0.56</					



Builders™ Vinyl (V-2500™)

The performance information listed is for new products and is intended to be used for reference only, and is not complete. Depending on the components, accessories, and options chosen, the actual rating could vary. Confirm ratings for specific products with supplier or JELD-WEN sales representative.

PRODUCT	GLAZING	No Grid				Qualifies for Energy Star				Flat or Contour Grids			Qualifies for Energy Star			
		U-Factor	SHGC	VT	CR	N	NC	SC	S	U-Factor	SHGC	VT	N	NC	SC	S
Tilt Single Hung PG 20	Clear	0.48	0.66	0.69	42					0.48	0.59	0.62				
	SunStable™	0.34	0.35	0.60	51					0.34	0.32	0.54				
	SunStable™ Argon	0.30	0.35	0.60	54		X			0.30	0.32	0.54		X		
	SunStable™ with HeatSave™	0.28	0.30	0.57	34		X			0.28	0.27	0.51		X		
	SunStable™ with HeatSave™ Argon	0.25	0.34	0.59	45	X	X			0.25	0.31	0.53	X	X		
	SunResist™	0.33	0.23	0.54	52				X	0.33	0.21	0.49				X
	SunResist™ Argon	0.29	0.23	0.54	55		X	X	X	0.29	0.21	0.49		X	X	X
	SunResist™ with HeatSave™	0.27	0.23	0.52	42	X	X	X	X	0.27	0.21	0.47	X	X	X	X
	SunResist™ with HeatSave™ Argon	0.25	0.23	0.53	45	X	X	X	X	0.25	0.21	0.47	X	X	X	X
	SunFlow™	0.34	0.55	0.66	52					0.34	0.49	0.59				
	SunFlow™ Argon	0.31	0.55	0.66	55					0.31	0.49	0.59				
	SunFlow™ with HeatSave™	0.28	0.52	0.64	41	X				0.28	0.47	0.57	X			
	SunFlow™ with HeatSave™ Argon	0.26	0.53	0.65	44	X				0.26	0.48	0.58	X			
	Energy Saver	0.30	0.35	0.60	54		X			0.30	0.32	0.54		X		
	Energy Saver Plus	0.29	0.23	0.54	55		X	X	X	0.29	0.21	0.49		X	X	X
	ENERGY STAR® Northern	0.30	0.55	0.66	57	X				0.30	0.48	0.59	X			
	ENERGY STAR® North Central	0.30	0.35	0.60	54		X			0.30	0.32	0.54		X		
	ENERGY STAR® South Central	0.29	0.23	0.54	55		X	X	X	0.29	0.21	0.49		X	X	X
	ENERGY STAR® Southern	0.33	0.23	0.54	52				X	0.33	0.21	0.49				X
	Tilt Single Hung PG 35/50	Clear	0.49	0.66	0.69	42					0.49	0.59	0.62			
SunStable™		0.34	0.35	0.60	51					0.34	0.32	0.54				
SunStable™ Argon		0.30	0.35	0.60	54		X			0.30	0.32	0.54		X		
SunStable™ with HeatSave™		0.28	0.30	0.57	34	X	X			0.28	0.27	0.51	X	X		
SunStable™ with HeatSave™ Argon		0.26	0.34	0.59	44	X	X			0.26	0.31	0.53	X	X		
SunResist™		0.34	0.23	0.54	52				X	0.34	0.21	0.49				X
SunResist™ Argon		0.30	0.23	0.54	55		X	X	X	0.30	0.21	0.49		X	X	X
SunResist™ with HeatSave™		0.28	0.23	0.52	42	X	X	X	X	0.28	0.21	0.47	X	X	X	X
SunResist™ with HeatSave™ Argon		0.26	0.23	0.53	45	X	X	X	X	0.26	0.21	0.47	X	X	X	X
SunFlow™		0.35	0.55	0.66	52					0.35	0.49	0.59				
SunFlow™ Argon		0.31	0.55	0.66	55					0.31	0.49	0.59				
SunFlow™ with HeatSave™		0.29	0.52	0.64	41	X				0.29	0.47	0.57	X			
SunFlow™ with HeatSave™ Argon		0.27	0.53	0.65	44	X				0.27	0.48	0.58	X			
Energy Saver		0.30	0.35	0.60	54		X			0.30	0.32	0.54		X		
Energy Saver Plus		0.30	0.23	0.54	55		X	X	X	0.30	0.21	0.49		X	X	X
ENERGY STAR® Northern		0.30	0.55	0.66	57	X				0.30	0.48	0.59	X			
ENERGY STAR® North Central		0.30	0.35	0.60	54		X			0.30	0.32	0.54		X		
ENERGY STAR® South Central		0.30	0.23	0.54	55		X	X	X	0.30	0.21	0.49		X	X	X
ENERGY STAR® Southern		0.34	0.23	0.54	52				X	0.34	0.21	0.49				X

© 2021 JELD-WEN, Inc. All rights reserved. | JELD-WEN, the JELD-WEN Logo, and the JW Logo are registered trademarks of JELD-WEN, Inc. BUILDERS VINYL, DF HYBRID, DF VINYL, HEATSAVE, PREMIUM ATLANTIC VINYL, PREMIUM VINYL, SUNFLOW, SUNRESIST, SUNSTABLE, V-2500 and V-4500 are trademarks of JELD-WEN, Inc. ENERGY STAR is a registered trademark of the US Environmental Protection Agency.



Building Envelope Engineering

"Energy Sensitive Design for a Healthier Building"™

NFRC U-FACTOR, SHGC, VT, & CONDENSATION RESISTANCE SIMULATION REPORT

REPORT TO:

Jiangxi Fangda Tech Co., Ltd.
Chihu Industrial Park, Jiujiang
Jiangxi, 332108 PR,
China

INSPECTION AGENCY:

N/A

REPORT NUMBER:	2310-3001-E1A0
SIMULATION DATE:	11/14/2023
REVISION DATE:	11/22/2023

PRODUCT: Inswing Doors

This simulation report includes NFRC ratings for a product, this report is not intended for NFRC Product Certification Program

This revision addresses IGU configuration options

170 West Dayton
St., Suite 206
Edmonds, WA
98020

P: 425 672 3900
F: 425 712 8608



Building Envelope Engineering

"Energy Sensitive Design for a Healthier Building"™

METHOD:

ANSI-NFRC 100, Procedure for Determining Fenestration Product U-Factors (2023)

ANSI-NFRC 200, Procedure for Determining Fenestration Product Solar Heat Gain Coefficients at Normal Incidence (2023)

NFRC 500, Procedure for Determining Fenestration Product Condensation Resistance Values (2017)

NFRC 2010 Technical Interpretations Manual (May 2023)

SOFTWARE:

Center of Glass: Window 7.8.71

2-D Heat Transfer: THERM 7.8.71

Total Product Calculations: doorsdr.xlsm

MODEL/TYPE:

Inswing Doors (EDSL)

SIMULATION SIZE:

960 mm X 2090 mm (38 in X 82 in)

FRAME TYPE AND FINISH:

VY, Vinyl (or other plastic) members with no reinforced members

Frame Options:

NAME	DESCRIPTION
Frame 1 (F1)	Constructed of RPVC with PU core and fiberglass skin, includes flat panel core and fiberglass glazing pressure system, 1/4 – Lite (LQ) Door Description
Frame 2 (F2)	Constructed of RPVC with PU core and fiberglass skin, includes contour panel core and fiberglass glazing pressure system, 1/2 – Lite (LQ) Door Description
Frame 3 (F3)	Constructed of RPVC with PU core and fiberglass skin, includes contour panel core and fiberglass glazing pressure system, 1/2 – Lite (LQ) Door Description
Frame 4 (F4)	Constructed of RPVC with PU core and fiberglass skin, includes contour panel core and fiberglass glazing pressure system, 3/4 – Lite (LQ) Door Description
Frame 5 (F5)	Constructed of RPVC with PU core and fiberglass skin, includes contour panel core and fiberglass glazing pressure system, 3/4 – Lite (LQ) Door Description
Frame 6 (F6)	Constructed of RPVC with PU core and fiberglass skin, Full Lite (LF) Door Description
Frame 7 (F7)	Constructed of RPVC with PU core and fiberglass skin, Full Lite (LF) Door Description
Frame 8 (F8)	Constructed of RPVC with PU core and fiberglass skin, includes contour panel core, Flush (FL) Door Description

WEATHERSTRIP:

TYPE	LOCATION (QUANTITY)
6 leaf FPVC sweep	Sill members at panel
Single leaf foam compression gasket PY kerf type	Head and Jamb members at frame

GLAZING METHOD:

INTERIOR	IGU secured to fiberglass lite frame with pressure system (fasteners not modeled)
EXTERIOR	IGU secured to fiberglass lite frame with pressure system (fasteners not modeled)

GAS FILL METHOD:

FILL TYPE	METHOD
Argon 90%	Single-Probe Timed Filling

(PROVIDED BY THE MANUFACTURER)



Building Envelope Engineering

"Energy Sensitive Design for a Healthier Building"™

SPACERS:

SPACER TYPE	PRIMARY SEALANT	SECONDARY SEALANT	CODE
Aluminum	Butyl	Polysulphide	A1-D
Aluminum	Butyl	Polysulphide	A8-S
Fiberglass	Butyl	Polysulphide	FG-S
Thermo-plastic	Acrylic adhesive (not modeled)	Polysulphide	TP-S

DIVIDERS/GRIDS (INTERNAL OR TDL):

NAME	SIZE	TYPE	PATTERN
Grid 1 (G1)	18 mm x 32 mm	Fiberglass SDL with AL (Anodized) Joined GBG	NFRC Standard
Grid 2 (G2)	18 mm x 32 mm	Fiberglass SDL with Swisspacer Joined GBG	NFRC Standard
Grid 3 (G3)	8 mm x 18 mm	AL (Anodized) Flat GBG	NFRC Standard
Grid 4 (G4)	8 mm x 18 mm	Swisspacer Flat GBG	NFRC Standard
Grid 5 (G5)	5 mm x 5.5 mm	Brass Flat H-Bar Caming	NFRC Standard
Grid 6 (G6)	6 mm	Iron Bar	NFRC Standard

SHADING SYSTEM:

CODE	TYPE	DESCRIPTION	DYNAMIC CAPABILITY
BH	Blinds, Horizontal Venetian	AL (Painted), integral at IGU	Retract, deploy, open, close

GRID TYPE

CODE	DESCRIPTION
G	Grids between the glass
N	No Grids
S	Simulated Divided Lites



Building Envelope Engineering

"Energy Sensitive Design for a Healthier Building"™

ADDITIONAL INFORMATION: The manufacturer is capable of producing, in its normal manufacturing process, products in sizes identical to the model sizes listed in the ANSI/NFRC 100 Table 4-3. All simulations are performed in the sizes and configurations listed in ANSI/NFRC 100 Table 4-3 except that a non-standard size may be simulated and identified in the matrix to match the manufacturer's physical test sample. Glass and glazing types, Low-E placement, finishes and other required information is included in the NFRC U-Factor Simulation Summary Report and/or the NFRC SHGC/VT Simulation Summary Report included in this document. Additional supporting information and modeling assumptions are included in the individual reports obtained from the approved simulation programs and in the notes following the required summary reports.

SIMULATION NOTES:

- 1) All simulations use the emissivity from the ANSI/NFRC approved files in IGDB Version 94.0.
- 2) For U-Factor purposes, all glazing options which vary only in glazing tint or obscuration are assumed to have the same U-Factor as glazing options without such tints or obscuration and are not simulated, provided that such options are not associated with a change in coating properties per ANSI/NFRC 100.
- 3) A default frame absorptance of 0.300 is assumed in accordance to ANSI/NFRC 200.
- 4) For Solar Heat Gain and Visible Light Transmittance; all frame, divider and glass options are grouped using the best case center of glass/worst case frame values from the "U" Factor calculations as required by ANSI/NFRC 200-2020.
- 5) The following material(s) used in this simulation are included in NFRC 101-2023 Appendix B or Appendix C:
 - a. SWISSPACER, SAINT GOBAIN SAN 35% Glass Fiber.
 - b. H.B. FULLER/ KÖMMERLING Kodispace 4SG
- 6) The material "Polyurethane" used in this simulation has been tested according to the ASTM C518-21 standard, report number 231008001SHF-001 issued on 10/18/2023.



Building Envelope Engineering

"Energy Sensitive Design for a Healthier Building"™

CONCLUSIONS

A bill of materials, detailed assembly drawings, and cross-section drawings supplied by the client were used as the basis for simulation. Copies are attached to this report (Appendix B). As required by, and in full compliance with NFRC procedures, the results were attained by using designated methods and approved simulation software. This report does not constitute certification of this product. The results in this report apply to the sample as shown in the attached drawings, using the components and construction methods described herein. BEE does not authenticate the accuracy of the software used to obtain the results.

This report is the joint property of BEE and the client to whom it is issued. Permission to reproduce this report by anyone other than BEE and the Client must be granted in writing by both of the above parties. This report may not be reproduced except in its entirety. Completed reports will be stored and save for a minimum of 5 years.

The Condensation Resistance results obtained from this procedure are for controlled laboratory conditions and do not include the effects of air movement through the specimen, solar radiation and the thermal bridging that may occur due to the specific design and construction of the fenestration system opening.

Ratings values included in this report are not meant to be used directly for labeling purposes. Only those options identified on a valid Certificate of Authorization (CA) by an NFRC accredited Inspection Agency (IA) are to be used for labeling purposes.

Units and rounding is in accordance with NFRC 601, Units and Measurement Policy except that all units may be reported in IP as the primary units after conversion and any matrix is reported in IP units, unless requested otherwise by the client.

Prepared by:

Anatolii Sapunov
Simulation Technician

Reviewed by:

Bret Joiner
Simulation Manager, SIRC

Attached:

APPENDIX A - Report Matrix
Revision Summary
APPENDIX B - Drawings



JIANGXI FANGDA TECH CO., LTD TEST REPORT

SCOPE OF WORK

NFPA 252 (2022), CAN / ULC S104 (2015) (R2020), UL 10(C) (2016) ED. 3 (R:27 MAY 2021) AND UL 10(B) (2008) (R2020) TESTING ON 20 MINUTES SINGLE SWING FIRE RATED FIBERGLASS DOOR AND FRAME

REPORT NUMBER

240305016SHF-001

TEST DATE

2024-05-30

ISSUE DATE

2024-07-18

PAGES

54

DOCUMENT CONTROL NUMBER

LFT-APAC-SHF-OP-10p (September 1, 2022)

© 2022 INTERTEK

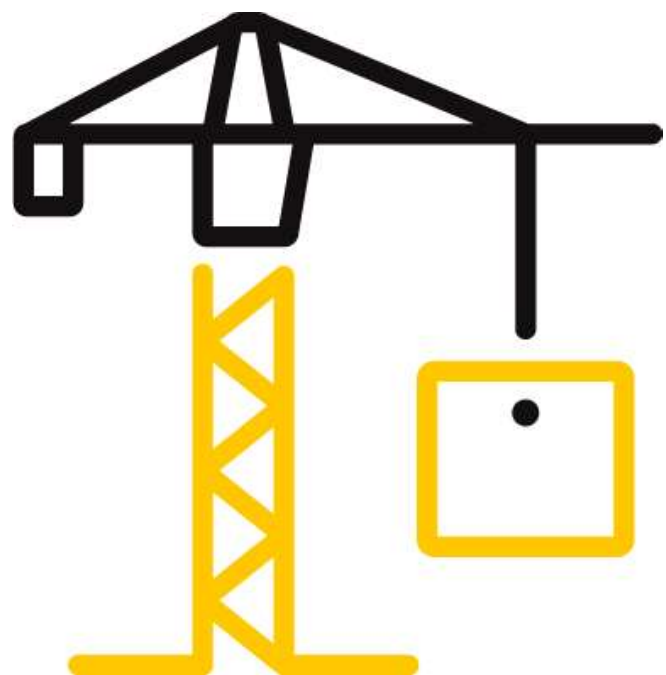



Total Quality. Assured.

Intertek Testing Services Shenzhen Ltd. Shanghai Fengxian Branch
 Plant 5, No. 6958 Daye Road, Fengxian District,
 Shanghai, China
 Tel: +86 21-61136116 Fax: 021-61189921
 Website: www.intertek.com

TEST REPORT

Issue Date: 2024-07-18

Intertek Report No.: 240305016SHF-001

REPORT ISSUED TO

JIANGXI FANGDA TECH CO., LTD

Tongjiang West Road, CHIHU INDUSTRIAL PARK, Jiujiang Jiangxi 332000 China

SECTION 1

SCOPE

Intertek has conducted an evaluation for JIANGXI FANGDA TECH CO., LTD to determine the fire resistance characteristics of the 20 Minutes Single Swing Fire Rated Fiberglass Door and Frame, model P01-03-8 and P02-06-8. This test was designed to demonstrate evaluation on the single swing fire rated fiberglass door and frame of seventeen types including Model P00-03-8, Model P02-05-8, Model P02-08-8, Model P03-06-8, Model P06-02-8, Model P00-01, Model P01-02-N, Model P02-01, Model P02-02, Model P02-03, Model P02-04, Model P03-03, Model P03-04, Model P05-01, Model P03-02, Model P04-02 and Model P06-01. This evaluation began on March 5, 2024 and was completed on July 18, 2024. The test was conducted on May 30, 2024.

The test was conducted in accordance with NFPA 252 (2022) and UL 10(C) (2016) ED. 3 (R:27 MAY 2021) under positive furnace pressure. This test was also designed to demonstrate evaluation according to CAN / ULC S104 (2015) (R2020) and UL 10(B) (2008) (R2020) under neutral furnace pressure. All the conditions of acceptance applying to the test door in NFPA 252 (2022) and UL 10(C) (2016) ED. 3 (R:27 MAY 2021) under positive furnace pressure, and in CAN / ULC S104 (2015) (R2020) and UL 10(B) (2008) (R2020) under neutral furnace pressure were taken into account simultaneously in this test.

Intertek B&C will service this report for the entire test record retention period. The test record retention period ends ten years after the test date. Test records, such as detailed drawings, datasheets, representative samples of test specimens (where required by Certification or Accreditation bodies), or other pertinent project documentation, will be retained for the entire test record retention period.

For INTERTEK B&C:

COMPLETED BY:	Ivy Qiu	REVIEWED BY:	Jason Xu
TITLE:	Project Engineer – Building & Construction	TITLE:	Operation Supervisor Building & Construction
SIGNATURE:		SIGNATURE:	
DATE:	2024-07-18	DATE:	2024-07-18



This report is for the exclusive use of Intertek's Client and is provided pursuant to the agreement between Intertek and its Client. Intertek's responsibility and liability are limited to the terms and conditions of the agreement. Intertek assumes no liability to any party, other than to the Client in accordance with the agreement, for any loss, expense or damage occasioned by the use of this report. Only the Client is authorized to permit copying or distribution of this report and then only in its entirety. Any use of the Intertek name or one of its marks for the sale or advertisement of the tested material, product or service must first be approved in writing by Intertek. The observations and test results in this report are relevant only to the sample(s) tested. This report by itself does not imply that the material, product, or service is or has ever been under an Intertek certification program.

The report was digital signed by Shang Hai, Intertek Group plc, please using Adobe Acrobat Reader to verify the authenticity.



Total Quality. Assured.

Intertek Testing Services Shenzhen Ltd. Shanghai Fengxian Branch
 Plant 5, No. 6958 Daye Road, Fengxian District,
 Shanghai, China
 Tel: +86 21-61136116 Fax: 021-61189921
 Website: www.intertek.com

TEST REPORT

Issue Date: 2024-07-18

Intertek Report No.: 240305016SHF-001

SECTION 2

SUMMARY OF TEST RESULTS

Product Name: 20 Minutes Single Swing Fire Rated Fiberglass Door and Frame

Series/Model: Model P01-03-8, Model P02-06-8, Model P00-03-8, Model P02-05-8, Model P02-08-8, Model P03-06-8, Model P06-02-8, Model P00-01, Model P01-02-N, Model P02-01, Model P02-02, Model P02-03, Model P02-04, Model P03-03, Model P03-04, Model P05-01, Model P03-02, Model P04-02 and Model P06-01

TEST RESULT FOR 20 MINUTES SINGLE SWING FIRE RATED FIBERGLASS DOOR AND FRAME, MODEL P01-03-8:

TITLE	RESULTS
Fire resistance with hose stream test	Met the requirements for a 20-minutes exposure period with hose stream

TEST RESULT FOR 20 MINUTES SINGLE SWING FIRE RATED FIBERGLASS DOOR AND FRAME, MODEL P02-06-8:

TITLE	RESULTS
Fire resistance with hose stream test	Met the requirements for a 20-minutes exposure period with hose stream

SECTION 3

TEST METHODS

The specimens were evaluated in accordance with the following:

NFPA 252 (2022), *Standard Methods of Fire Tests of Door Assemblies*

CAN / ULC S104 (2015) (R2020), *Standard Method for Fire Tests of Door Assemblies*

UL 10(C) (2016) ED. 3 (R:27 MAY 2021), *Standard for Positive Pressure Fire Tests of Door Assemblies*

UL 10(B) (2008) (R2020), *Standard for Fire Tests of Door Assemblies*



Total Quality. Assured.

Intertek Testing Services Shenzhen Ltd. Shanghai Fengxian Branch
Plant 5, No. 6958 Daye Road, Fengxian District,
Shanghai, China
Tel: +86 21-61136116 Fax: 021-61189921
Website: www.intertek.com

TEST REPORT

Issue Date: 2024-07-18

Intertek Report No.: 240305016SHF-001

After the hose stream, no through openings were apparent and the door latch remained engaged to the strike. The measured deflection of the edge adjacent to the door frame neither exceeded the allowable deflection limit of 1-1/2 times the door thickness, nor more than 66.75 mm after the hose stream test.

The test assembly including doorset, Model P01-03-8 and Model P02-06-8 therefore met the hose stream portion of the test.

A full set of test data is included in Section 10, and photographs have been presented in Section 11.

SECTION 6

CONCLUSION

The 20 Minutes Single Swing Fire Rated Fiberglass Door and Frame, model P01-03-8 and P02-06-8 identified in this report have been tested in accordance with NFPA 252 (2022) and UL 10(C) (2016) ED. 3 (R:27 MAY 2021) under positive furnace pressure. This test has also demonstrated evaluation according to CAN / ULC S104 (2015) (R2020) and UL 10(B) (2008) (R2020) under neutral furnace pressure.

The 20 Minutes Single Swing Fire Rated Fiberglass Door and Frame, model P01-03-8 met the requirements for a 20-minute exposure period with hose stream.

The 20 Minutes Single Swing Fire Rated Fiberglass Door and Frame, model P02-06-8 met the requirements for a 20-minute exposure period with hose stream.

The successful testing with the two doorsets is directly applicable to the 20 Minutes Single Swing Fire Rated Fiberglass Door and Frame, Model P00-03-8, Model P02-05-8, Model P02-08-8, Model P03-06-8, Model P06-02-8, Model P00-01, Model P01-02-N, Model P02-01, Model P02-02, Model P02-03, Model P02-04, Model P03-03, Model P03-04, Model P05-01, Model P03-02, Model P04-02 and Model P06-01.



Total Quality. Assured.

Intertek Testing Services Shenzhen Ltd. Shanghai Fengxian Branch
 Plant 5, No. 6958 Daye Road, Fengxian District,
 Shanghai, China
 Tel: +86 21-61136116 Fax: 021-61189921
 Website: www.intertek.com

TEST REPORT

Issue Date: 2024-07-18

Intertek Report No.: 240305016SHF-001

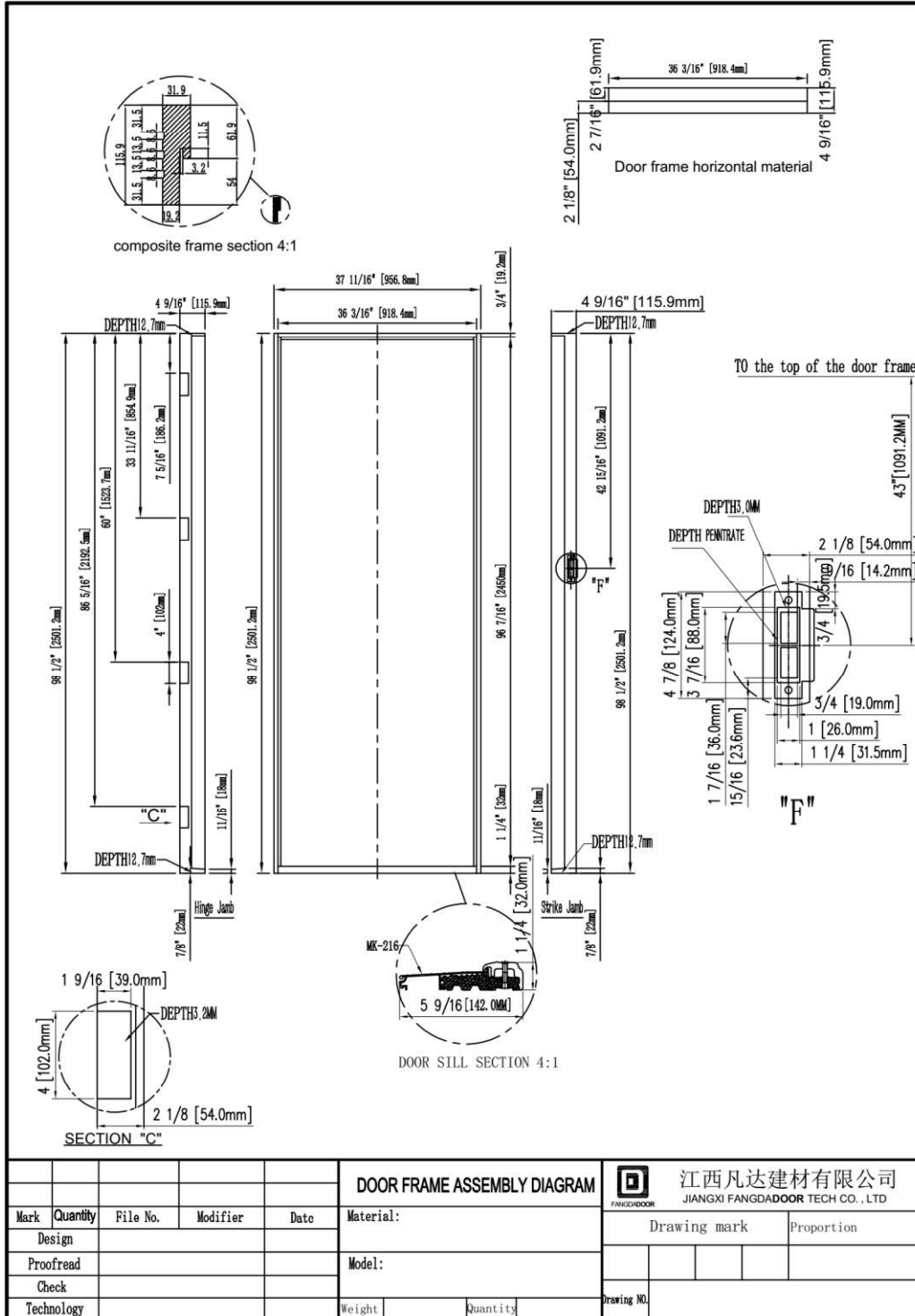

Assembly Drawing of the Frame



Total Quality. Assured.

Intertek Testing Services Shenzhen Ltd. Shanghai Fengxian Branch
 Plant 5, No. 6958 Daye Road, Fengxian District,
 Shanghai, China
 Tel: +86 21-61136116 Fax: 021-61189921
 Website: www.intertek.com

TEST REPORT

Issue Date: 2024-07-18

Intertek Report No.: 240305016SHF-001

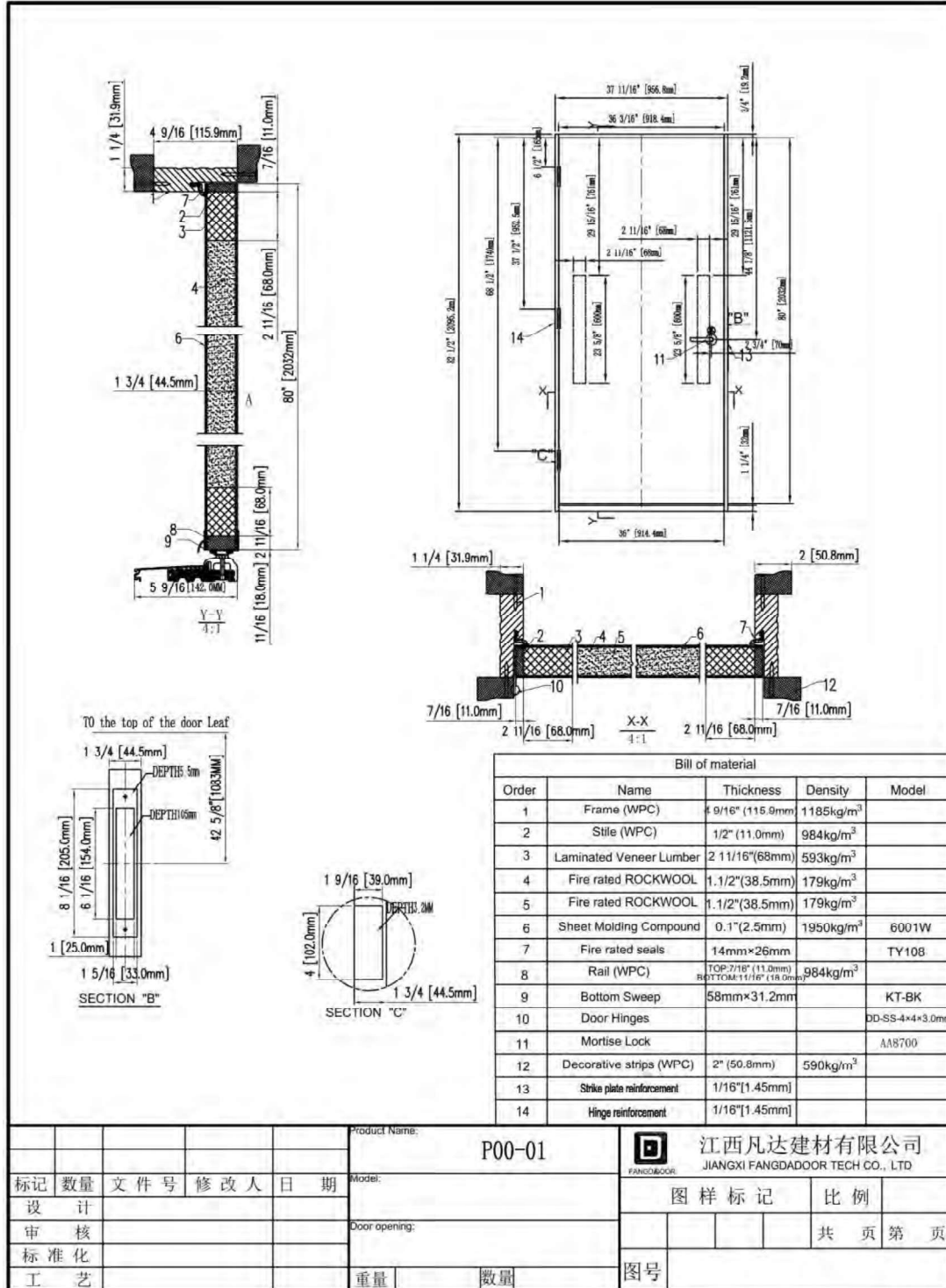

Assembly Drawing of Fiberglass Door and Frame, model P00-01



Total Quality. Assured.

Intertek Testing Services Shenzhen Ltd. Shanghai Fengxian Branch
Plant 5, No. 6958 Daye Road, Fengxian District,
Shanghai, China
Tel: +86 21-61136116 Fax: 021-61189921
Website: www.intertek.com

TEST REPORT

Issue Date: 2024-07-18

Intertek Report No.: 240305016SHF-001

SECTION 8

TEST WALL CONSTRUCTION

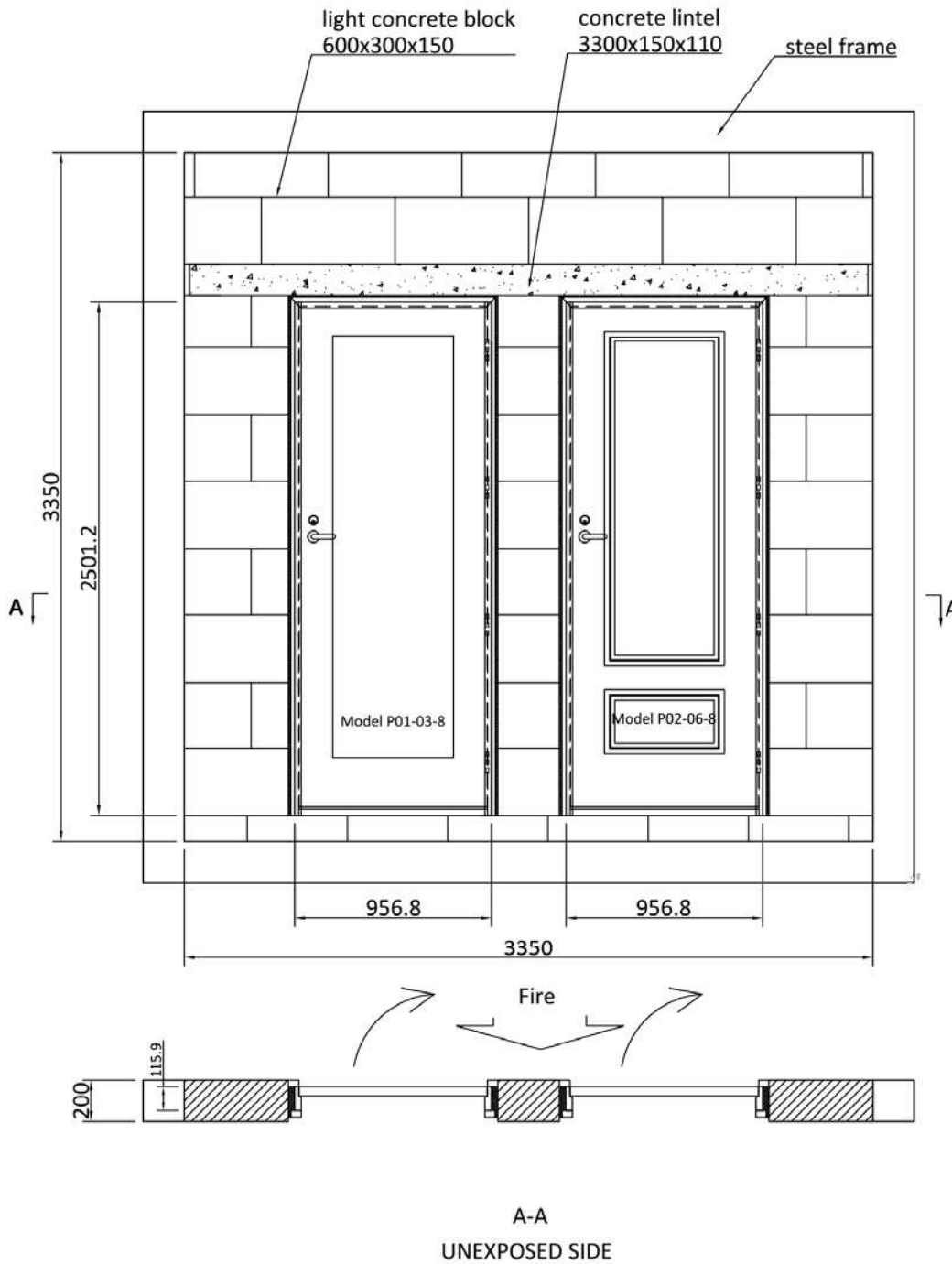



Intertek Testing Services Shenzhen Ltd. Shanghai Fengxian Branch
 Plant 5, No. 6958 Daye Road, Fengxian District,
 Shanghai, China
 Tel: +86 21-61136116 Fax: 021-61189921
 Website: www.intertek.com

TEST REPORT

Issue Date: 2024-07-18

Intertek Report No.: 240305016SHF-001

SECTION 9

TEST MEASUREMENT DATA

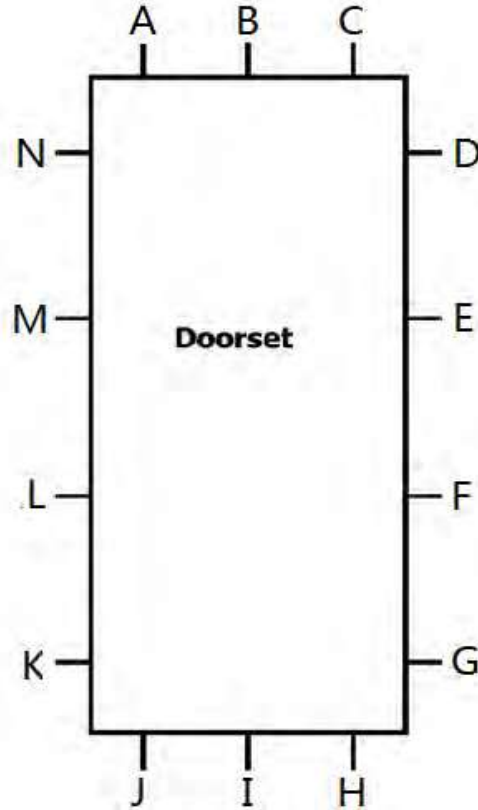

EXPOSED SIDE

Clearance dimension in mm at each position of Model P01-03-8						
A	B	C	D	E	F	G
1.5	0.5	1.8	0.6	0.6	1.8	1.5
H	I	J	K	L	M	N
/	/	/	1.1	0.9	1.2	1.2

DO NOT SCALE

DOOR ASSEMBLY INITIAL CLEARANCES

Note: The clearances of Location H ~ J were not measured due to a bottom sweep under the bottom of the door.



Total Quality. Assured.

Intertek Testing Services Shenzhen Ltd. Shanghai Fengxian Branch
 Plant 5, No. 6958 Daye Road, Fengxian District,
 Shanghai, China
 Tel: +86 21-61136116 Fax: 021-61189921
 Website: www.intertek.com

TEST REPORT

Issue Date: 2024-07-18

Intertek Report No.: 240305016SHF-001

SECTION 10 TEST DATA

Standards: NFPA 252 (2022) Fire Tests of Door Assemblies

Equipment:

ITEM	ID
Vertical furnace	SH1097
Furnace pressure gauge	SH1097-15-1~2
Test Clock	SH1042
Furnace thermocouple	SH1097-1
Ambient temperature gauge	SH1097-11
Unexposed thermocouple	SH1097-12 & SH1097-12-1~11
Clearance Measurements	SH1506
Displacement Measurements	SH1377-1~11 & SH1377-13~15
Oxygen Analyzer	SH1233

- Temperature-Time Curve: According to NFPA 252, Section 4.1
- Furnace Temperatures: According to NFPA 252, Section 4.2
- Unexposed Temperatures: According to NFPA 252, Section 4.3, measured in the first 30 minutes
- Thermocouple Pads: Length and width 152 ± 3 mm, thickness 10.2 ± 1.3 mm, conductivity 0.055 W/mK at 65°C
- Construction and Size: According to NFPA 252, Section 5.1
- Mounting: According to NFPA 252, Section 5.2
- Clearances: According to NFPA 252, Section 5.3
- Test Wall: According to NFPA 252, Section 5.4
- Hose Stream: According to NFPA 252, Section 6.2



Total Quality. Assured.

Intertek Testing Services Shenzhen Ltd. Shanghai Fengxian Branch
 Plant 5, No. 6958 Daye Road, Fengxian District,
 Shanghai, China
 Tel: +86 21-61136116 Fax: 021-61189921
 Website: www.intertek.com

TEST REPORT

Issue Date: 2024-07-18

Intertek Report No.: 240305016SHF-001

Other Evaluation Standard:

UL 10(B) (2008) (R2020)	DESCRIPTION
Positive Pressure	No requirement.
Neutral pressure	The pressure in the furnace chamber is to be 0 ± 0.01 inches of water at the top of the door.
Thermocouple	For unexposed temperatures, thermocouple shall be a wire diameter of not more than 0.7mm. Each thermocouple is to be brazed to the center of the surface of the face of a copper disk 12mm in diameter and 0.2mm thick.
Thermocouple Pads	Length and width 152 ± 3 mm, thickness 9.5 ± 1.6 mm, dry weight of 67 ± 24 g, conductivity 0.053 W/mK at 66°C, modified Brinnell hardness (on soft face) of 2.25 to 4.5.
Cotton Pad Check	No Requirement.
Hose Stream	Immediately after to within 3 minutes of the fire endurance test.

CAN / ULC S104 (2015) (R2020)	DESCRIPTION
Positive pressure	No requirement.
Neutral pressure	The pressure in the furnace chamber shall be controlled such that a pressure of 0 ± 2.5 Pa is maintained at the top of the test assembly.
Thermocouple	For unexposed temperatures, thermocouple lead under the pad shall be not greater than 1 mm in diameter and shall be electrically insulated with heat resistant and moisture resistant coatings.
Thermocouple Pads	Length and width 150 ± 3 mm, thickness 10 ± 1 mm, density 500 ± 10 kg/m ³ , thermal conductivity 0.055 W/m·K at 66°C.
Cotton Pad Check	No Requirement.
Hose Stream	Within 3.5min of the termination of the fire test, directed first at the bottom and then at all parts of the exposed surface, changes in direction being made slowly.



Total Quality. Assured.

Intertek Testing Services Shenzhen Ltd. Shanghai Fengxian Branch
 Plant 5, No. 6958 Daye Road, Fengxian District,
 Shanghai, China
 Tel: +86 21-61136116 Fax: 021-61189921
 Website: www.intertek.com

TEST REPORT

Issue Date: 2024-07-18

Intertek Report No.: 240305016SHF-001

UL 10(C) (2016) ED. 3 (R:27 MAY 2021)	DESCRIPTION
Positive pressure	After less than 5 minutes, 40 in. (1016 mm) or less from the bottom of the test assembly.
Neutral pressure	No requirement.
Thermocouple	For unexposed temperatures, thermocouple shall be a wire diameter of not more than 0.7mm. Each thermocouple is to be brazed to the center of the surface of the face of a copper disk 12mm in diameter and 0.2mm thick.
Thermocouple Pads	Length and width 30 ± 0.5 mm, thickness 2 ± 0.5 mm, density of 900 ± 100kg/m ³ , thermal conductivity 0.053 W/mK at 66°C, modified Brinnell hardness (on soft face) of 2.25 to 4.5.
Cotton Pad Check	100mm square by 20mm thick, consist of new undyed and soft cotton fibers without any admixture of artificial fibers, weighing of 3 to 4g, dried at 100°C for at least 30min. Attached by wire clips to a 100mm square frame of 1mm diameter wire.
Hose Stream	Immediately after and within 3 minutes of the fire endurance test.
Oxygen Percentage readings	The oxygen percentage is to be determined by centering a minimum of one 1/4-in (6.4-mm) inside diameter stainless steel tube containing eight 1/16-inch (1.6-mm) diameter holes in the damper plenum, approximately half way between the furnace and the exhaust damper. The tube is then to be connected to an oxygen analyzer which has an accuracy of ±2.0 percent in the range of 0 to 10 percent. Locating more than one probe in the plenum and averaging the readings is permitted.



Total Quality. Assured.

Intertek Testing Services Shenzhen Ltd. Shanghai Fengxian Branch
 Plant 5, No. 6958 Daye Road, Fengxian District,
 Shanghai, China
 Tel: +86 21-61136116 Fax: 021-61189921
 Website: www.intertek.com

TEST REPORT

Issue Date: 2024-07-18

Intertek Report No.: 240305016SHF-001

Temperature Data:

Mean furnace temperature together with temperature-time relationship specified in the standard

Time Mins	Specified Furnace Temperature (°C)	Furnace Mean Temperature (°C)
0	20	27
1	124	36
2	227	89
3	331	199
4	434	354
5	538	518
6	571	629
7	604	670
8	638	699
9	671	719
10	704	736
11	715	758
12	726	775
13	738	779
14	749	783
15	760	785
16	767	788
17	774	787
18	781	788
19	788	788
20	795	788



Intertek Testing Services Shenzhen Ltd. Shanghai Fengxian Branch
Plant 5, No. 6958 Daye Road, Fengxian District,
Shanghai, China
Tel: +86 21-61136116 Fax: 021-61189921
Website: www.intertek.com

TEST REPORT

Issue Date: 2024-07-18

Intertek Report No.: 240305016SHF-001

Graph for mean furnace temperature and temperature-time curve specified in the standard

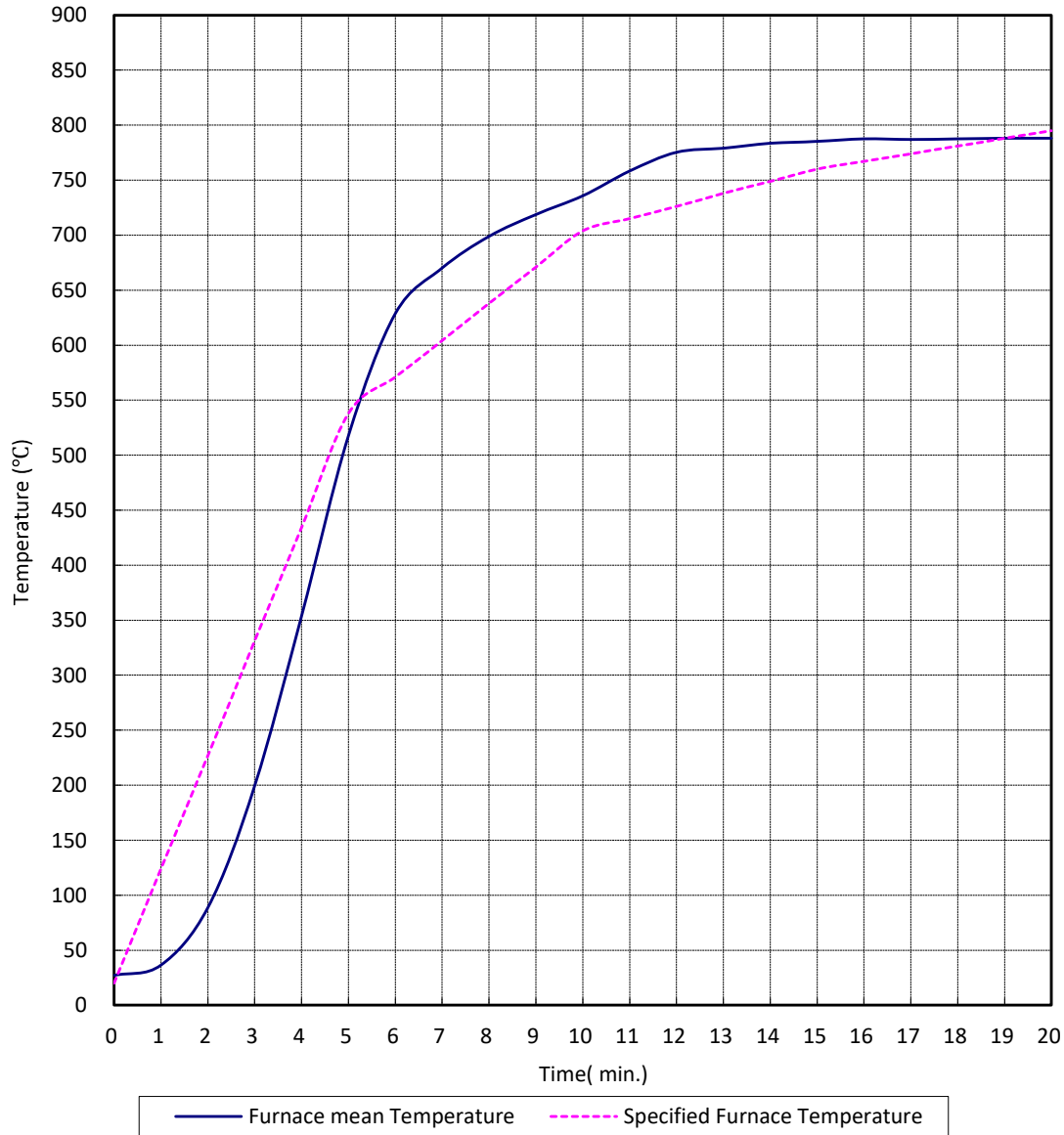



Total Quality. Assured.

Intertek Testing Services Shenzhen Ltd. Shanghai Fengxian Branch
Plant 5, No. 6958 Daye Road, Fengxian District,
Shanghai, China
Tel: +86 21-61136116 Fax: 021-61189921
Website: www.intertek.com

TEST REPORT

Issue Date: 2024-07-18

Intertek Report No.: 240305016SHF-001

Graph for Furnace Pressure

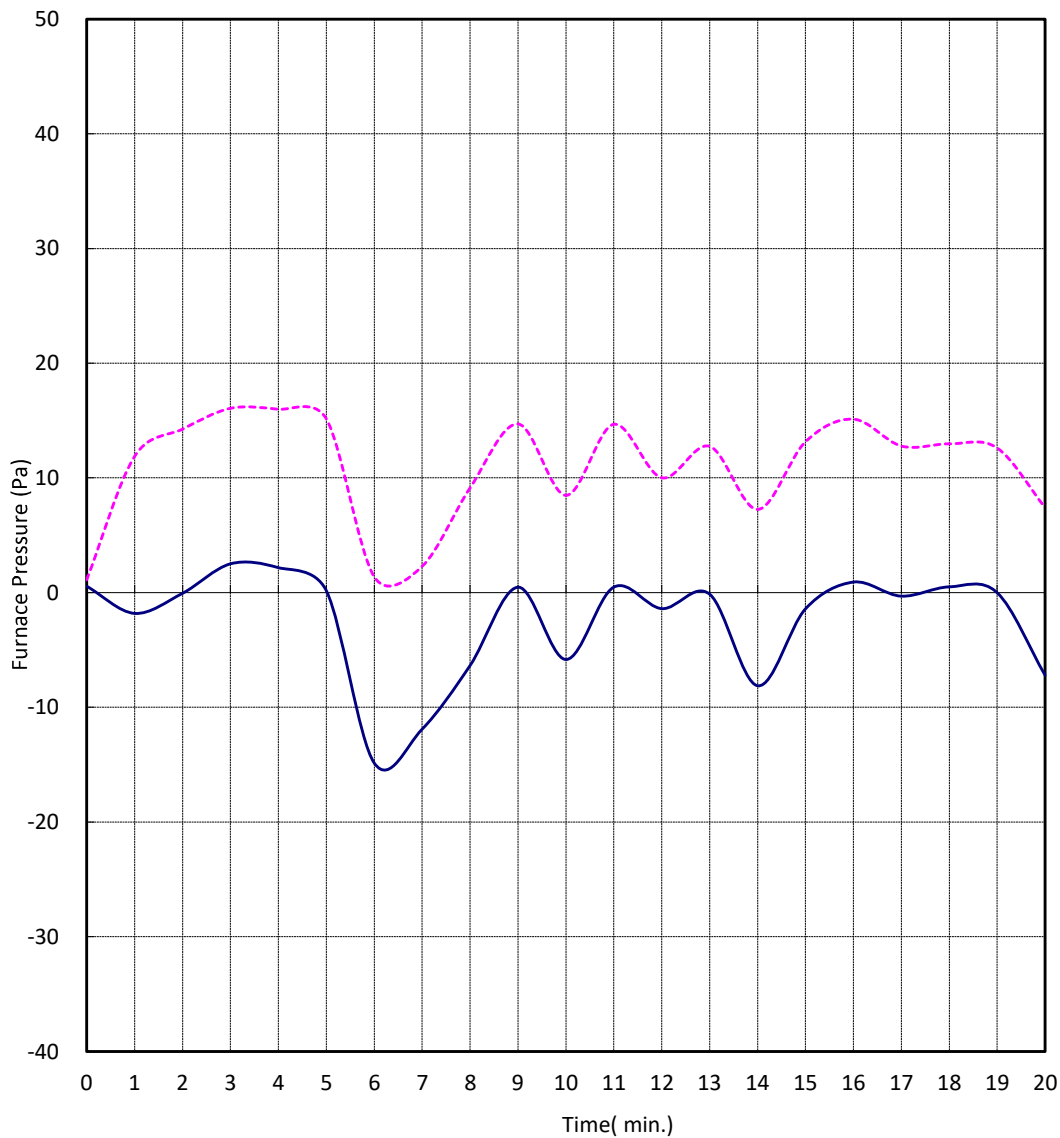

— P1: Pressure at 1000mm above the notional floor level
- - - P2: Pressure at 2500mm above the notional floor level



Total Quality. Assured.

Intertek Testing Services Shenzhen Ltd. Shanghai Fengxian Branch
Plant 5, No. 6958 Daye Road, Fengxian District,
Shanghai, China
Tel: +86 21-61136116 Fax: 021-61189921
Website: www.intertek.com

TEST REPORT

Issue Date: 2024-07-18

Intertek Report No.: 240305016SHF-001

Graph for oxygen concentration inside furnace

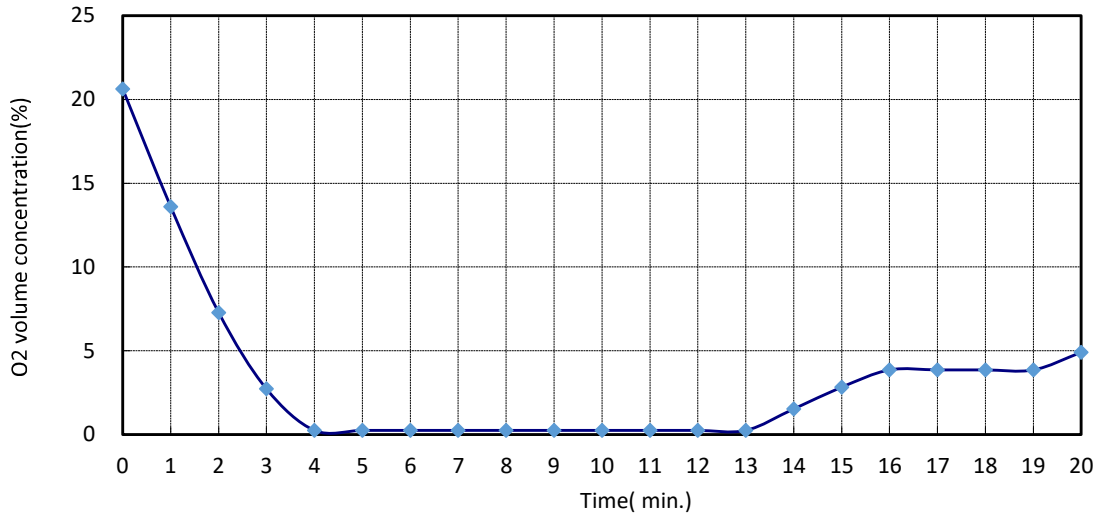



Intertek Testing Services Shenzhen Ltd. Shanghai Fengxian Branch
Plant 5, No. 6958 Daye Road, Fengxian District,
Shanghai, China
Tel: +86 21-61136116 Fax: 021-61189921
Website: www.intertek.com

TEST REPORT

Issue Date: 2024-07-18

Intertek Report No.: 240305016SHF-001

SECTION 11 PHOTOGRAPHS



Fig. 1 Exposed Side Prior to the Fire Test



Fig. 2 Unexposed Side Prior to the Fire Test



Total Quality. Assured.

Intertek Testing Services Shenzhen Ltd. Shanghai Fengxian Branch
Plant 5, No. 6958 Daye Road, Fengxian District,
Shanghai, China
Tel: +86 21-61136116 Fax: 021-61189921
Website: www.intertek.com

TEST REPORT

Issue Date: 2024-07-18

Intertek Report No.: 240305016SHF-001



Fig. 3 Unexposed Side after 10 Minutes



Fig. 4 Unexposed Side after 20 Minutes



Total Quality. Assured.

Intertek Testing Services Shenzhen Ltd. Shanghai Fengxian Branch
Plant 5, No. 6958 Daye Road, Fengxian District,
Shanghai, China
Tel: +86 21-61136116 Fax: 021-61189921
Website: www.intertek.com

TEST REPORT

Issue Date: 2024-07-18

Intertek Report No.: 240305016SHF-001



Fig. 5 Exposed Side after 20 Minutes

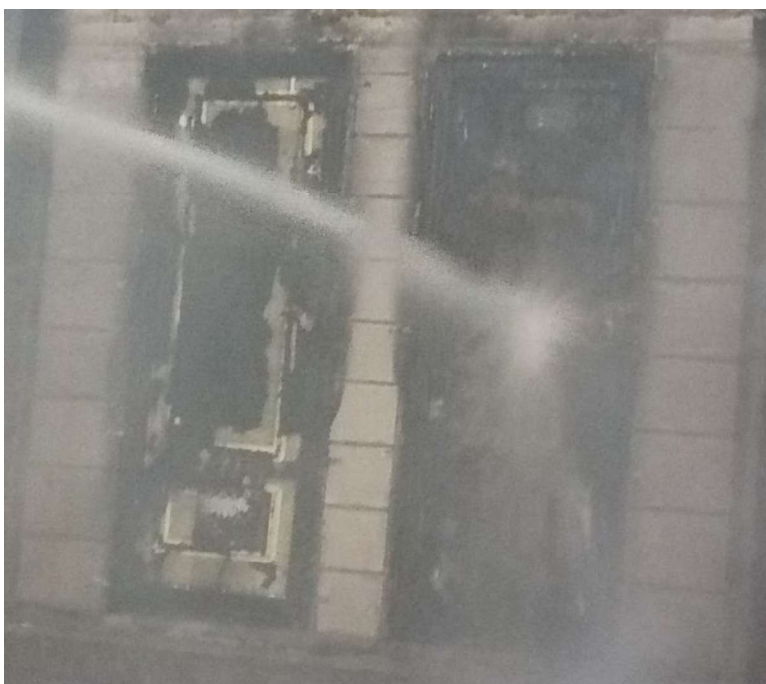

Fig. 6 Exposed Side during Hose Stream Test



Total Quality. Assured.

Intertek Testing Services Shenzhen Ltd. Shanghai Fengxian Branch
Plant 5, No. 6958 Daye Road, Fengxian District,
Shanghai, China
Tel: +86 21-61136116 Fax: 021-61189921
Website: www.intertek.com

TEST REPORT

Issue Date: 2024-07-18

Intertek Report No.: 240305016SHF-001



Fig. 7 Unexposed Side after Hose Stream Test

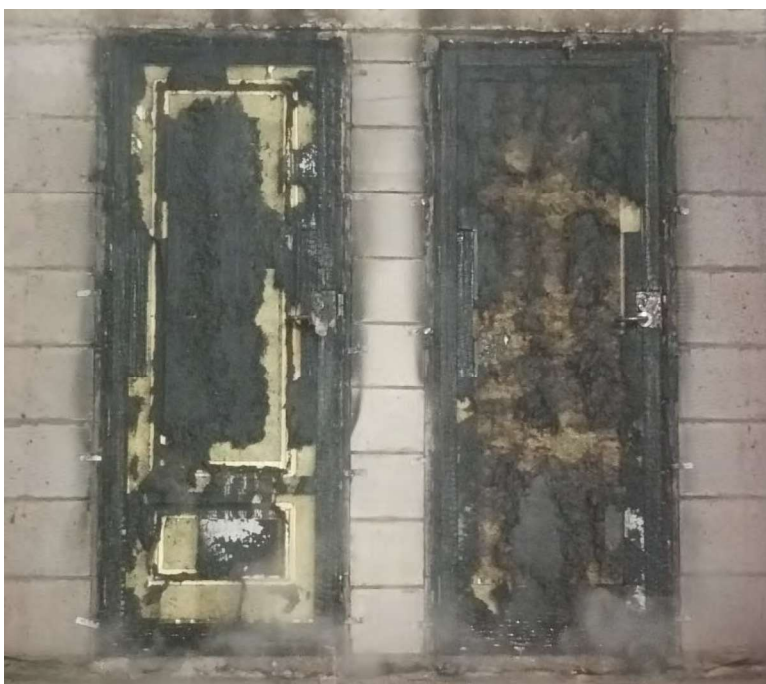

Fig. 8 Exposed Side after Hose Stream Test



Total Quality. Assured.

Intertek Testing Services Shenzhen Ltd. Shanghai Fengxian Branch
Plant 5, No. 6958 Daye Road, Fengxian District,
Shanghai, China
Tel: +86 21-61136116 Fax: 021-61189921
Website: www.intertek.com

TEST REPORT

Issue Date: 2024-07-18

Intertek Report No.: 240305016SHF-001

SECTION 12 REVISION LOG

REVISION #	DATE	PAGES	REVISION
0	2024-07-18	N/A	Original Report Issue



Job Name/Location:

Tag #:

Date:

For: File Resubmit
 Approval Other _____

PO No.:

Architect: GC:

Engr: Mech:

Rep:

(Company)

(Project Manager)



LS120HFV3

Single Zone Standard Efficiency Wall Mount

Outdoor Unit (ODU) - LSU120HFV3, Indoor Unit (IDU) - LSN120HFV3

Performance:

Cooling:

Cooling Capacity (Min~Rated~Max) (Btu/h)	3,070 ~ 12,000 ~ 13,780
SEER	17.00
EER	9.60

SEER - Seasonal Energy Efficiency Ratio

EER - Energy Efficiency Ratio

Heating:

Heating Capacity (Min~Rated~Max) (Btu/h)	3,070 ~ 12,000 ~ 13,780
Max. Heating @ Indoor 70°F DB Outdoor 19°F DB / 17°F WB	9,640
HSPF	9.0

HSPF - Heating Seasonal Performance Factor

Cooling Nominal Test Conditions:

Indoor: 80°F DB / 67°F WB

Outdoor: 95°F DB / 75°F WB

Heating Nominal Test Conditions:

Indoor: 70°F DB / 60°F WB

Outdoor: 47°F DB / 43°F WB

Electrical:

Power Supply (V/Hz/Ø)	208-230 / 60 / 1
-----------------------	------------------

Outdoor Unit:

MOP (A)	15
MCA (A)	10
Cooling Rated Amps (A)	7.4
Heating Rated Amps (A)	7.4
Compressor (A)	7.0
Fan Motor (A)	0.4

MOP - Maximum Overcurrent Protection

MCA - Minimum Circuit Ampacity

Total Power Input:

Cooling Power Input (kW)	1.25
Heating Power Input (kW)	1.05

Piping:

Liquid Line (in., O.D.)	1/4
Vapor Line (in., O.D.)	3/8
Additional Refrigerant (oz./ft.)	0.22
Min. / Max. Pipe Length (ft.) ²	9.8 / 49.2
Piping Length (no add'l refrig., ft.)	24.6
Max. Elevation (ft.)	23

Features:

- 24-Hour on/off timer
- 2-Way (up / down) auto swing
- Auto changeover
- Auto restart
- Jet cool/let heat
- Condensate sensor connection
- Energy saving
- Inverter (variable speed compressor)
- Self-cleaning indoor coil
- Sleep mode
- Ultra quiet operation

Included Accessories:

- Wireless Remote Controller — AKB74955602

Optional Accessories:

- MultiSITE™ CRC1 — PREMTBVC0
- MultiSITE CRC1+ — PREMTBVC1
- Simple Remote Controller — PREMTCC00U
- Premium Remote Controller — PREMTA000
- Dry Contact - PDRYCB100/320/400

For a complete list of available accessories, contact your LG representative.

For continual product development, LG reserves the right to change specifications without notice.

© LG Electronics U.S.A., Inc., Englewood Cliffs, NJ. All rights reserved. "LG Life's Good" is a registered trademark of LG Corp. /www.lghvac.com

Operating Range:

Outdoor Unit:

Cooling (°F DB)	14 to 118
Heating (°F WB)	14 to 65

Indoor Unit:

Cooling (°F WB)	53 to 75
Heating (°F DB)	60 to 86

System Data:

Refrigerant Type	R410A
Refrigerant Control	EEV
Refrigerant Charge (lbs.)	1.875
ODU Sound Pressure (Cooling / Heating) (±1 dB[A]) ³	50 / 50
IDU Sound Pressure Cooling (H/M/L/Sleep) (±1 dB[A]) ³	42 / 36 / 28 / 21
Heating (H/M/L) (±1 dB[A]) ³	42 / 36 / 28
ODU Net / Shipping Weight (lbs.)	55.3 / 60
IDU Net / Shipping Weight (lbs.)	19.2 / 25.4
Heat Exchanger Coating	GoldFin™

Fan:

ODU Type	Propeller
IDU Type	Cross Flow
Fan Speeds (Fan/Cool/Heat)	6 / 6 / 6
Quantity (ODU + IDU)	1 + 1
Motor/Drive	Brushless Digitally Controlled/Direct
ODU Max. Air Flow Rate (CFM)	953
IDU Air Flow Cooling, Max/H/M/L (CFM)	459 / 353 / 264 / 148
Heating, Max/H/M/L (CFM)	459 / 353 / 254 / 198
Dehumidification (pts./hr.)	2.75

Notes:

1. Acceptable operating voltage: 187V-253V.
2. Piping lengths are equivalent.
3. Sound Pressure levels are tested in an anechoic chamber under ISO Standard 3745.
4. All communication / connection (power) cable from the outdoor unit to the indoor unit is field supplied and must be a minimum of four-conductor, 14 AWG, stranded, shielded or unshielded (if shielded, it must be grounded to the chassis of the outdoor unit only), and must comply with applicable local and national codes.
5. See Engineering Manual for sensible and latent capacities.
6. Power wiring cable size must comply with the applicable local and national code.
7. The indoor unit comes with a dry helium charge.
8. This data is rated 0 ft. above sea level, with 24.6 ft. of refrigerant line and a 0 ft. level difference between outdoor and indoor units.
9. Must follow installation instructions in the applicable LG installation manual.



Job Name/Location: _____

LS120HFV3

Single Zone Standard Efficiency Wall Mount

Outdoor Unit (ODU) - LSU120HFV3, Indoor Unit (IDU) - LSN120HFV3



Tag No.: _____

Date: _____

PO No.: _____

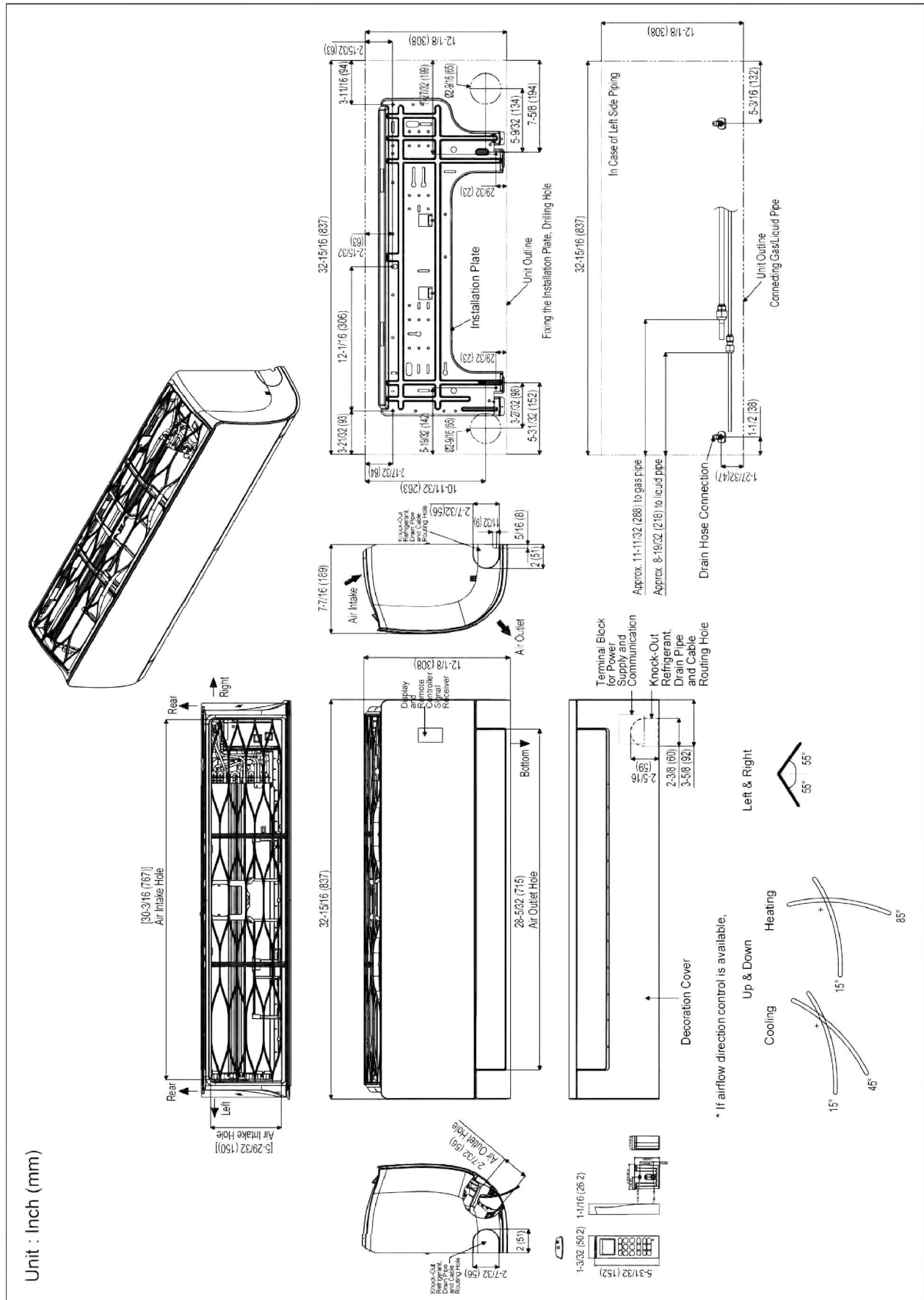

Job Name/Location: _____

LS120HFV3

Single Zone Standard Efficiency Wall Mount

Outdoor Unit (ODU) - LSU120HFV3, Indoor Unit (IDU) - LSN120HFV3



Tag No.: _____

Date: _____

PO No.: _____

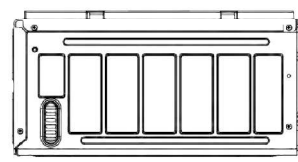
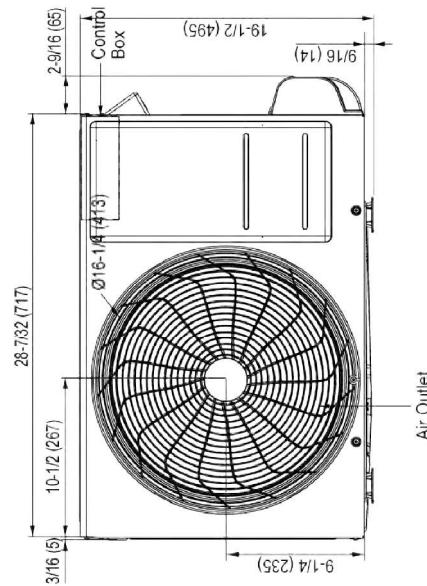
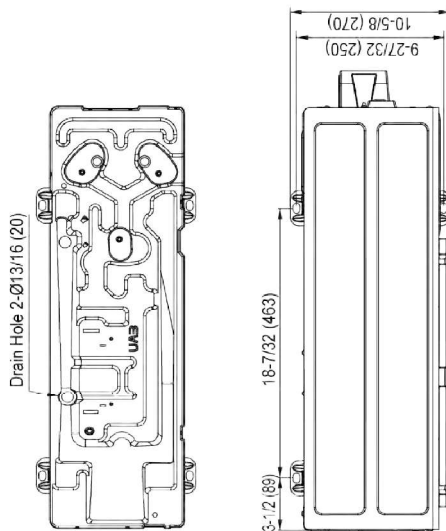
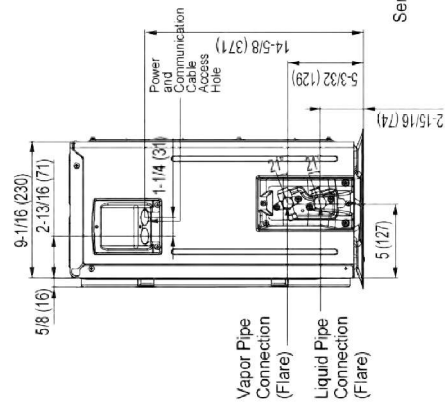
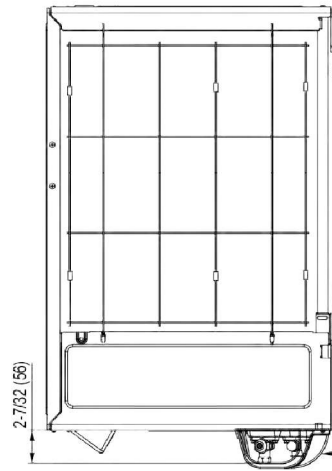
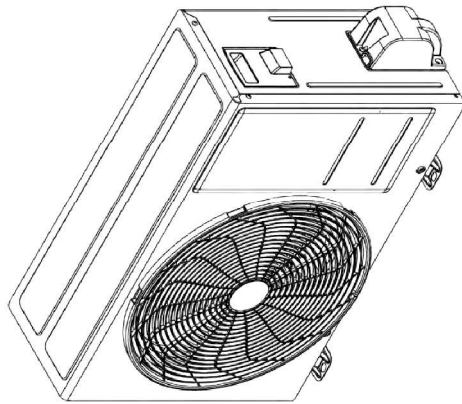

Unit: Inch (mm)



Delta BreezSlim Ventilation Super Low Profile Fan Specifications

SLM70
(70 CFM)

Dimensions

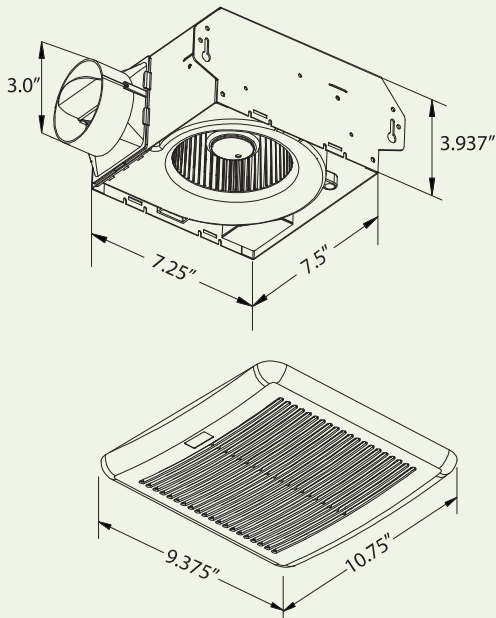

Fan Curve

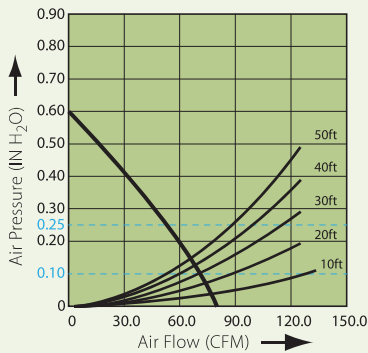

Description

Low noise ceiling/wall mount ventilating fan with super low profile, rated for continuous running. Evaluated by Underwriter Laboratories and conforms to both UL and cUL safety standards.

Motor/Blower

- Power rating of 120volts/60Hz.
- DC brushless motor engineered to run continuously.
- Motor equipped with thermal cutoff fuse.
- Removable with permanently lubricated plug-in motor.

Housing

- Galvanized steel body.
- Detachable 3" diameter duct adapter.
- Built-in backdraft damper.
- Easy installation.

Grille

- Attractive design using ABS material.
- Attaches directly to housing with torsion springs.

Warranty

- 3-year limited warranty.

Features

- For ceiling and wall mount, air flow of 70 CFM (±10%) and 2.0 sones at 0.1" static pressure.
- Power consumption approximately 13.1 Watts with an efficiency rating approximately 5.8 CFM/Watt at 0.1" static pressure.
- Duct diameter no less than 3".
- UL and cUL listed for tub/shower enclosure when used with GFCI branch circuit wiring.

DC Motor Technology

- Built-in soft start function to increase bearings' life.
- Automatically powers OFF when impeller is locked abnormally.

Specifications

	SLM70	3" Duct (Standard)
Static Pressure (Inches w.g.)	0.1	0.25
Air Flow (CFM)	70	54
Sones	2.0	1.5
Power Consumption (Watts)	13.1	11.5
Energy Efficiency (CFM/Watt)	5.8	5.0
Speed (RPM)	1239	1369
Current (Amps)	0.29 Max	
Power Rating (V/Hz)	120/60	



4405 Cushing Parkway | Fremont, CA 94538
tel 1.888.979.9889 | www.deltabreez.com



ECO-PAIR+ SINGLE ROOM ENERGY RECOVERY VENTILATOR



AV-TTW5-W

Suitable for
10~20 m²
rooms



97% up to

Regeneration
Efficiency



FEATURES

- Elegant decorative front panel
- Reversible fan with low energy consumption
- Silent operation
- Indoor air quality monitor
- Mold prevention
- F7 (MERV11) filter
- Auto shutter to prevent air back drafting
- Installation can be done internally only
- Wireless pairing operation
- Smart phone control Android /IOS

WIRELESS OPERATION IN PAIR TO ENSURE BALANCED VENTILATION



CONTROL & FUNCTIONS

- Timer
- Weekly Schedule
- Filter Alarm
- Scene Control
- Multiple Linkage Control
- Group Control
- Wireless Pairing Operation
- Smart Control According to Local Weather
- Work with Alexa and Google Assistant
- Free Cooling
- Fan Boost Function
- Optional Negative Ion
- Optional CO₂ Control
- Optional Humidity Control



Download the APP for **smart vent** at Google Play market and App Store.



TECHNICAL PARAMETERS

Model No. : AV-TTW5-W			
Voltage	100V-240V AC /50-60Hz	Max Input Power (W)	12.1
Air Flow in Supply/ Exhaust Mode (CMH)	60/70/80 (L/M/H)	Air Flow in Supply/ Exhaust Mode (CFM)	35/41/47 (L/M/H)
Current (A)	0.063	Regeneration Efficiency (%)	≤97
Noise (3m) dB(A)	≤ 41	Ingress Protect Rating	IPX4
Max RPM	2800	SEC Class	A
Diameter of Duct (mm)	158	Product Size (mm)	239.6x258x227.2 (The length of duct in wall is 150 mm)
Weight (kg)	4.3		



5001 E. Philadelphia Street, Ontario, CA 91761-2816 (909) 472-4100 FAX (909) 472-4250

CONTINUOUS COMPLIANCE INSPECTION REPORT AND SIGNATURE SHEET

Listee: BOXABL

Mfr. (if different): SEAL VACUUM FORMING

Mfr. Address: NO. 238 NORTH ROAD,, LIANGTIAN INDUSTRIAL PARK

City: ZHONGLUOTAN TOWN, BA

State: GD

Zip: 510545

Country: CHI

Phone: 13825103617

Fax:

Email: IM2@seal-vf.com

ISO 9000 Certified?: Yes No If Yes, Name of Registrar

Plant Hours:

Warehouse where listed products are shipped: listee in US

Files Inspected: NEW - 1/1

Inspection Type: Initial Inspection Method: On-Site Inspection per R-019 R-072

Additional Listing(s) Inspected:

Inspection Summary: All Satisfactory**Items Inspected:**

<input checked="" type="checkbox"/> Plant information sheet reviewed by plant contact for correctness	Needs Revision see note 1
<input checked="" type="checkbox"/> Review Certificate of Listing for correctness	Not Applicable initial
<input checked="" type="checkbox"/> Current version of standard on site	Satisfactory
<input checked="" type="checkbox"/> Examine product markings, including dual language safety labeling, when applicable, according to their listing. List the model numbers reviewed	Not Applicable initial
<input checked="" type="checkbox"/> Assess use of IAPMO R&T Certification Marks	Not Applicable initial
<input checked="" type="checkbox"/> Check calibration records randomly for equipment used in plant testing and verify the calibration certificates are current and from an accredited calibration lab showing the appropriate accreditation agency logo	Satisfactory
<input checked="" type="checkbox"/> Verify that finished products are inspected or tested on a regular basis by manufacturer	Satisfactory
<input checked="" type="checkbox"/> Verify method of segregating non-conforming products	Satisfactory
<input checked="" type="checkbox"/> Conduct dimensional in-plant verification where applicable	Not Applicable
<input checked="" type="checkbox"/> Review literature	Satisfactory
<input checked="" type="checkbox"/> Review complaint records	Satisfactory
<input checked="" type="checkbox"/> Review calibration records for equipment used in the production of listed products and verify the calibration certificates are current and from an accredited calibration lab showing the appropriate accreditation agency logo	Satisfactory
<input checked="" type="checkbox"/> Review if any changes in design or material for listed products have been made since certification. Describe changes	Satisfactory
<input checked="" type="checkbox"/> Review quality manual system records and practices against Procedure R-019	Satisfactory
<input checked="" type="checkbox"/> Review the effectiveness of corrective action on non-conformances found at previous inspection	Not Applicable
<input checked="" type="checkbox"/> Review of raw material, component, and ingredient suppliers against Finalized Formulation List (FFL)	Not Applicable
<input checked="" type="checkbox"/> Verify components shown on the FFL are used on the listed product	Not Applicable
<input checked="" type="checkbox"/> Review of blending sheets	Not Applicable
<input checked="" type="checkbox"/> Select Product for Testing at Random. For in-house testing, provide equipment ID and calibration dates for the instruments used and, when required by standard, report environmental conditions.	N/A
<input checked="" type="checkbox"/> Was the remote inspection method used effective in achieving the assessment objectives? Describe method used	Not Applicable
<input type="checkbox"/> Other:	

[For Plastic Pipe products please complete this Matrix](#)

2023-05-16 19:37:32

Page 1 of 2

Sample Selection (The sample(s) that are to be sent to the laboratory shall be shipped out within 48 hours of the collection date)

File No.	No. of Sample(s)	Backup Sample(s)	Model No.	Standard	Section(s) of Standard	Mfg Date	Testing Location
----------	------------------	------------------	-----------	----------	------------------------	----------	------------------

This is an initial inspection for this location.

Note 1: Factory contact name shall be Allen Luo, phone number is 13825103617.

Confirmed factory had a copy of the latest version of IAPMO Z124, satisfied.

Reviewed daily inspection procedure and records for incoming material, in-process products and final products, satisfied.

Went through the production line and the warehouse, confirmed non-conformance product/material will be tagged and segregated, satisfied.

Randomly reviewed calibration records, satisfied.

Made it clear to the factory contact that certification logo can only be used with listee brand name on listed products.

Confirmed factory QC process can meet the requirement for R-019.

Signature of the Plant Contact below indicates acknowledgement that a) he/she witnessed the presence of the IAPMO R & T inspector whose signature appears below at this plant/warehouse location on the day indicated, b) he/she acknowledges receipt of a completed copy of this form, c) he/she will see to it that a complete copy of this form is delivered to the responsible person in charge at this location. The Plant Contact signature does not indicate agreement or disagreement with the information entered onto this form.

Reminder: Please confirm client's website contains proper IAPMO listing / certification information.

DONE

Reminder: Record results and observations including model numbers and leave a copy of inspection report with plant contact

DONE

Facility Contact Signature:



Signature

Print Name:

Allen Luo

If a physical signature could not be captured, this checkbox confirms that the contact mentioned here participated with the IAPMO R&T inspector throughout the entirety of this inspection and has been made aware of the results stated above.

IAPMO R&T Inspector

Signature:



Signature

Print Name:

Lance Wang

If a physical signature could not be captured, this checkbox confirms that this represents the signature of the IAPMO R&T inspector.

OT:

CC Staff Review:

Penalty Hours:

Signature

6032STTM – EVERYDAY TUB/SHOWERS

60 x 32 x 83 inches



FEATURES

- Tub-shower
- Subway tile finish
- Ergonomic backrest
- Above-floor rough
- Slip-resistant textured bottom
- Left or right hand drain
- AcrylX™ applied acrylic surface
- Lifetime limited warranty

OPTIONS

- Grab bar reinforcement
- Factory installed assisted care grab bars
- Designer drain, waste & overflow

AQUATIC ADVANTAGE

- National distribution
- 7 manufacturing facilities
- Private fleet
- Centralized customer service
- Field support

COLOR OPTIONS

Stock	Upgraded	Premium
White	Almond Biscuit/Linen Bone	Black Mexican Sand Sand Bar Sterling Silver





TECHNICAL SPECIFICATIONS

6032STTM

60 x 32 x 83 inches

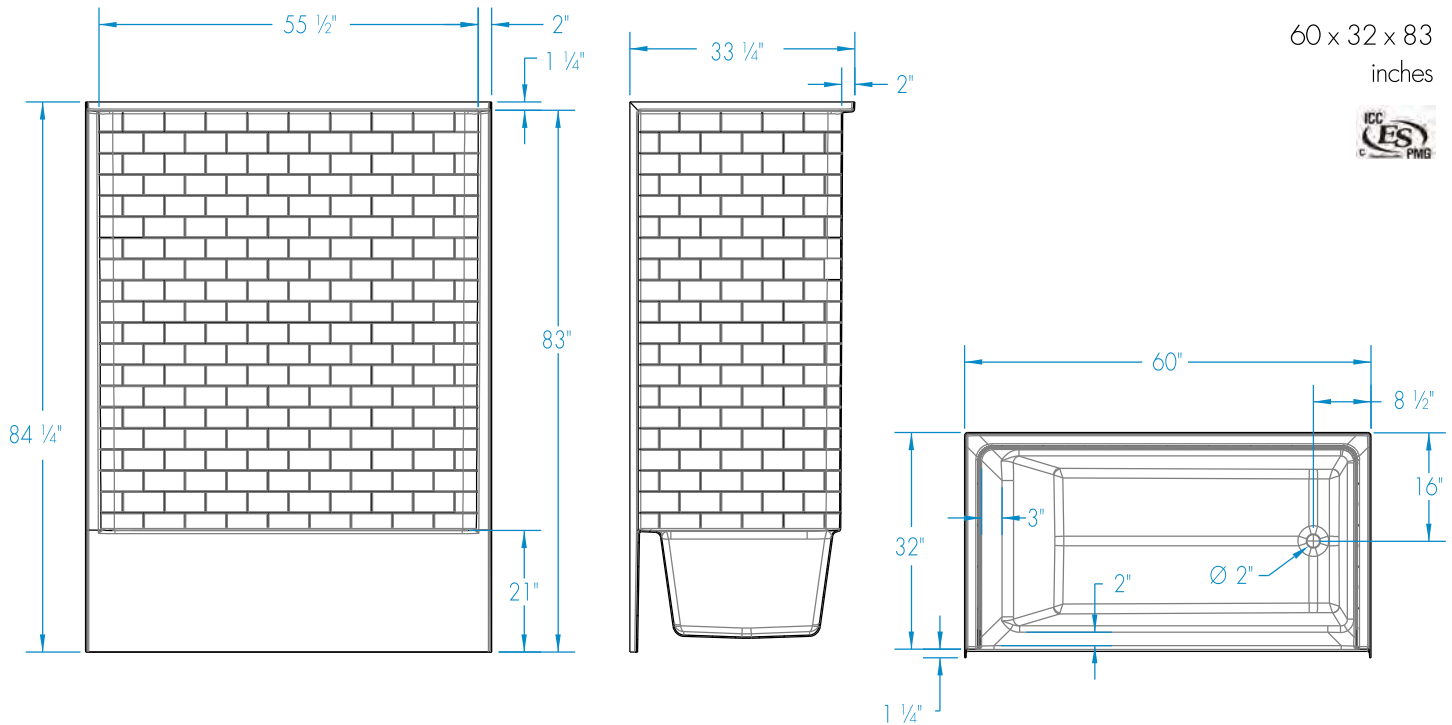

FEATURES lbs Dimensional Tolerance $\pm 3/8"$. Dimensions needed for site preparation should be measured from the unit. Aquatic assumes no responsibility for preparatory work.

Model #	Material	Wall Finish	Jets	Motor	Controls	Drain	Net Wt.	Pkg. Wt.
AFR Tub-Shower #6032STTM	AcrylX™	Subway Tile	-	-	-	LH or RH	140	145

DIMENSIONS

Specifications	inches
Width: Overall / Net	60
Depth: Overall / Net	32 / 33 1/4
Height: Overall / Net	84 1/4 / 83
Enclosure Opening	55 1/2
Skirt Height	21
Drain Rough-In (from Back Wall)	16
Drain Rough-In (from Side Wall)	2 1/8
Drain: Diameter / Clearance	2 / 3 3/4

FRAMING DIMENSIONS inches

Type	D Depth	W Width	H Height	A	B	C
Alcove	33 1/2	60 1/8	-	Box Out	2 1/8	16

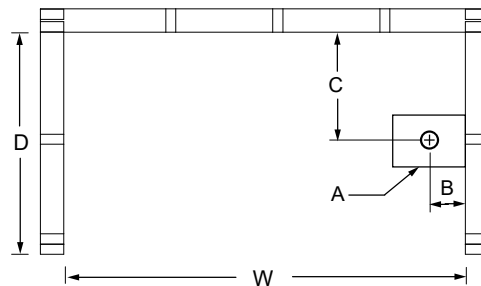

SUMP DATA

Top of Drain to Bottom of Overflow	Capacity to Overflow gal	Min. Operating Capacity gal	WIDTH @ centerline		DEPTH @ centerline	
			Top	Bottom	Top	Bottom
12 3/8	52	-	49 3/8	42 1/4	25 1/8	21 3/8



The new degree of comfort.®

Residential Electric
Professional *Prestige* ProTerra
Hybrid Water Heaters

Professional *Prestige*® ProTerra™ Hybrid Electric is the most efficient water heater available

Efficiency

- Up to 4.07 UEF reduces operating cost
- ENERGY STAR® rated
- Title 24 Compliant (JA13 Ready)

Performance

- Delivers hot water faster than most standard electric water heaters
- Ambient operating range: 37-145° F is widest in class, offering more days of HP operation annually; designed to meet Northern Climate Spec (Tier 4)

Easy Installation

- Easy access side connections
- Quick access to electrical junction box
- Easily replaces a standard electric water heater

Integration

- Electronic control for easy temperature adjustment and mode management
- Audible alarm for service alerts
- Integrated EcoNet® WiFi-connected* technology and free mobile app gives users control over water heater, allowing for customizable temperature, vacation settings, energy savings and system monitoring at home or away.
- Demand Response Ready with built-in EcoPort/ CTA-2045 port
- LeakGuard™ and LeakSense™ Ready — Easily add leak detection and prevention with leak sensor and shutoff valve upgrade kit

Operation Modes

- Energy Saver
- Heat Pump
- High Demand
- Electric
- Vacation/Away: 2-28 days (or placed on hold indefinitely)

Plus...

- Premium grade anode rod with resistor extends the life of the tank
- 3/4" NPT water inlet and outlet; 3/4" condensate drain connections
- Incoloy stainless steel resistor elements
- Dry-fire protection
- Easy access, top mounted washable air filter
- 2" Non-CFC foam insulation
- Enhanced flow brass drain valve
- Temperature and pressure relief valve installed
- Design certified to NSF/ANSI 372 (Lead Content)

Warranty

- 10-Year limited tank and parts warranty
See Residential Warranty Certificate for complete information

Units meet or exceed ANSI requirements and have been tested according to D.O.E. procedures. Units meet or exceed the energy efficiency requirements of NAECA, ASHRAE standard 90, ICC Code and all state energy efficiency performance criteria.



Professional *Prestige* ProTerra Hybrid

40, 50, 65 and 80-Gallon
Capacities
208-240 Volt / 1 PH
Electric



LEED Points = 3

*WiFi broadband internet connection required.

See specifications chart on next page.



INTEGRATED HOME COMFORT

Professional *Prestige*® ProTerra Hybrid Specifications

DESCRIPTION					ENERGY INFO	FEATURES							SHIPPING WEIGHTS	
NOMINAL GALLON CAPACITY	RATED GALLON CAPACITY	MODEL NUMBER	MODEL VARIANT	ELECTRIC BREAKER SIZE	UNIFORM ENERGY FACTOR (UEF)	COMPRESSOR BTU/H	UEF FIRST HR. RATING G.P.H.	RECOVERY IN G.P.H 90° F RISE	ELEMENT WATTAGE	TOTAL UNIT WATTAGE	MAX AMPS	UNIT WT. (LBS.)	APPROX. SHIP WT. (LBS.)	
ProTerra 30 Amp														
40	36	PROPH40 T2 RH375-30	700470	30	3.83	4,200	60	27	4,500	5,000	21	157	174	
50	45	PROPH50 T2 RH375-30	700467	30	3.88	4,200	67	27	4,500	5,000	21	178	218	
65	59	PROPH65 T2 RH375-30	700468	30	4.05	4,200	75	27	4,500	5,000	21	225	262	
80	72	PROPH80 T2 RH375-30	700469	30	4.07	4,200	87	27	4,500	5,000	21	244	281	
ProTerra 15 Amp														
40	36	PROPH40 T2 RH375-15	700497	15	3.45	4,200	46	16	2,250	2,750	12	157	174	
50	45	PROPH50 T2 RH375-15	700494	15	3.75	4,200	52	16	2,250	2,750	12	178	218	
65	59	PROPH65 T2 RH375-15	700495	15	3.55	4,200	54	16	2,250	2,750	12	225	262	
80	72	PROPH80 T2 RH375-15	700496	15	3.70	4,200	67	16	2,250	2,750	12	244	281	

Uniform Energy Factor and rated gallon capacity based on Department of Energy (DOE) requirements. All units have integrated WiFi control board.

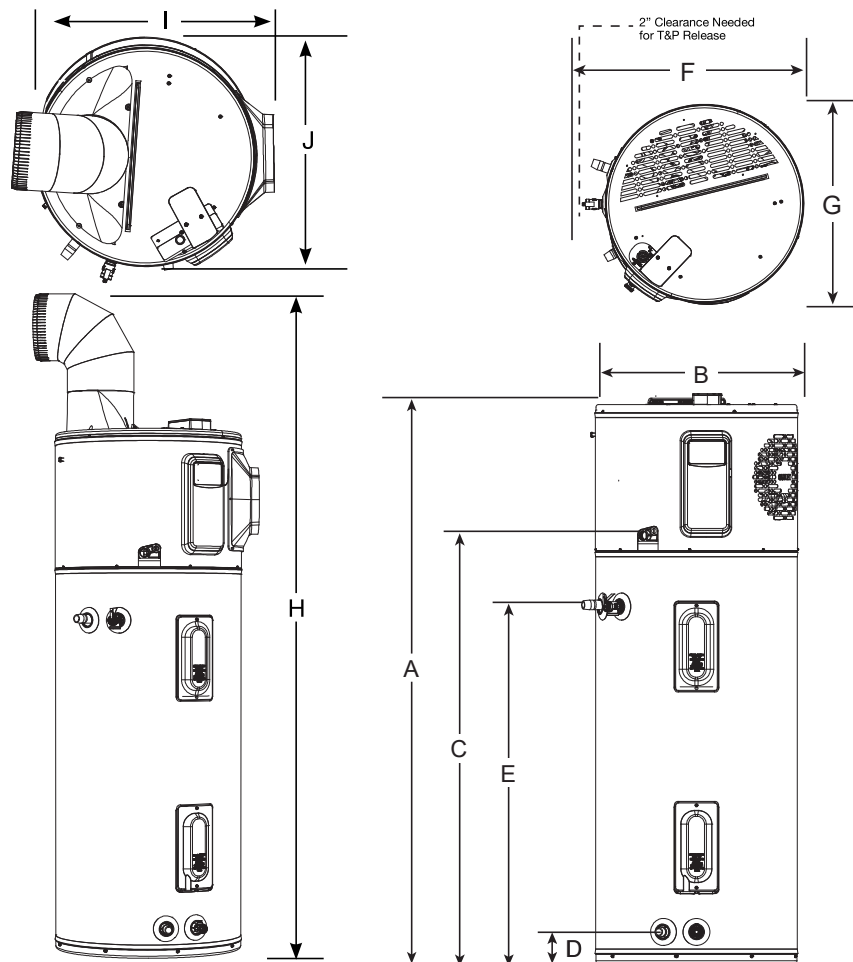

DESCRIPTION		DIMENSIONS (SHOWN IN INCHES)									
NOMINAL GALLON CAPACITY	MODEL NUMBER	A	B	C	D	E	F	G	H	I	J
40	PROPH40	62-5/16	20-1/4	47	3-5/8	39-5/8	25-3/8	20-1/2	78-7/8	22-3/8	21-3/4
50	PROPH50	61-3/4	22-1/4	47	3-5/8	39-5/8	27-3/8	22-1/2	78-5/8	24-3/8	23-11/16
65	PROPH65	64-3/16	24-1/4	49	3-7/8	42-3/8	29-1/2	24-5/8	81-1/8	26-1/2	25-13/16
80	PROPH80	74-3/16	24-1/4	59	3-7/8	42-3/8	29-1/2	24-5/8	91	26-1/2	25-11/16

Hybrid Water Heater Installation Guidelines to Provide Optimal Efficiency

Heater: Not Ducted

Room size: Larger than 700 ft³ (e.g. 7' x 10' x 10').
 Requirements: No additional ventilation needed.

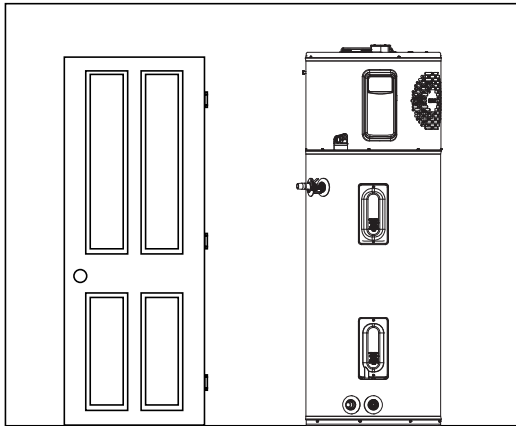

Heater: Not Ducted

Room size: Smaller than 700 ft³ (e.g. 7' x 10' x 10').
 Requirements: Full louvered door OR two louvers top and bottom. See below.

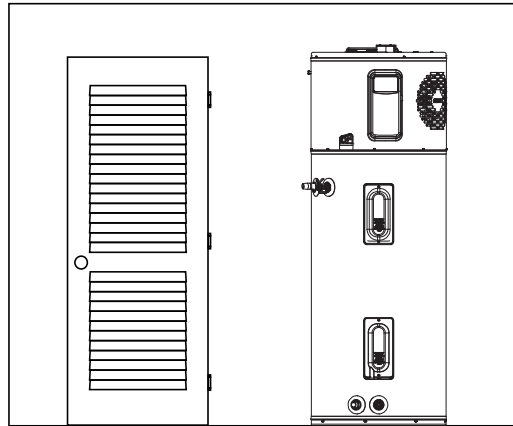

Heater: Not ducted

Room: Small Closet

- Requirements: * Air gap under door equal to 18 in² (0.75" clearance).
- * Louver must be located the same height on door as the air exhaust on heater.
- * Heater air exhaust must be positioned towards louver within one foot of door.

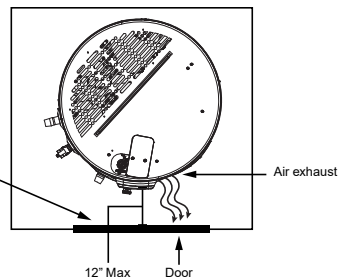
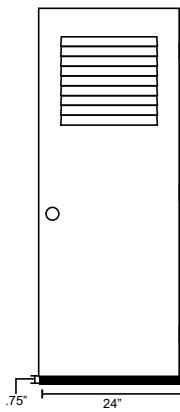

Heater: Ducted with inlet OR outlet duct

Room size: Any size room
 Requirements: Air gap under door equal to 18 in² (0.75" clearance)

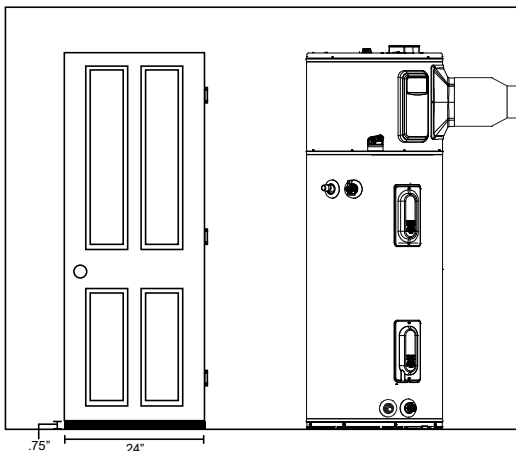

Heater: Ducted with inlet AND outlet duct

Room size: Any size room
 Requirements: No additional ventilation needed.

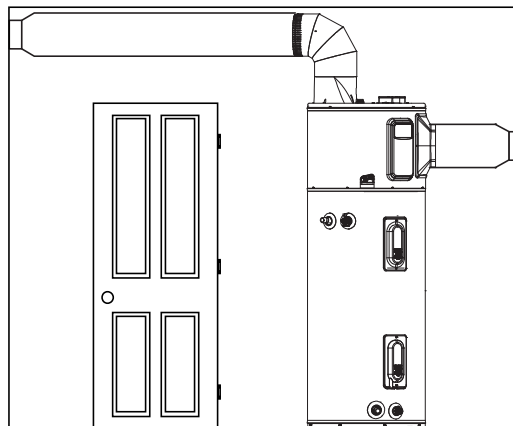



The new degree of comfort.



Hybrid Accessories List

PART NUMBER	DESCRIPTION	USE FOR
AP19134	Leak Sensor	Automatic detection of internal and external leaks
AP20180	Shutoff Valve	Automatic shut off of water supply to unit
SP21105	Inlet Duct Adapter Kit	Allows for ducting to be connected on the top inlet
SP17829	Outlet Duct Adapter Kit	Allows for ducting to be connected to the unit
SP20882	Earthquake Isolation Kit	Installations in seismic regions
SP20883	Vibration Isolation Kit	Installation on non-concrete floors
SP20884	8" Diameter UL Certified Termination Kit	Termination to the outside or to the attic with 8" diameter
SP20885	7" Diameter UL Certified Termination Kit	Termination to the outside or to the attic with 7" diameter
SP20886	6" Diameter UL Certified Termination Kit	Termination to the outside or to the attic with 6" diameter
SP20887	5" Diameter UL Certified Termination Kit	Termination to the outside or to the attic with 5" diameter
SP20888	8" Rheem Approved Damper Kit	Exhaust only to the outside ducting configuration (no inlet duct)
SP20889	25' Flexible 8" Diameter Duct Kit	For up to 25' of ducting
SP20890	Rigid Elbow Duct Kit	Installation in tight places where space needs to be minimized
UPGRADE KIT		
SP21111	Leak Sensor & Shutoff Valve Kit	Add leak detector and shutoff valve to protect from water damage

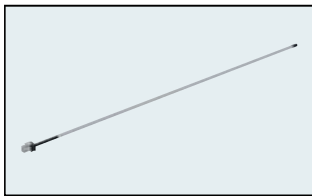

Leak Sensor



Shutoff Valve



Inlet Duct Adapter Kit



Outlet Duct Adapter Kit



Earthquake Isolation Kit

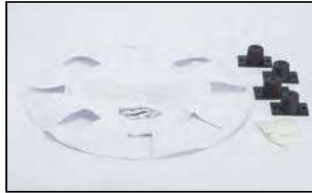

Vibration Isolation Kit

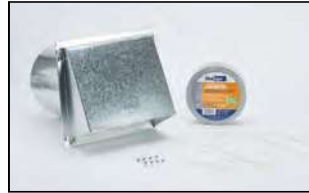

8" Diameter UL Certified Termination Kit



7" Diameter UL Certified Termination Kit



6" Diameter UL Certified Termination Kit



5" Diameter UL Certified Termination Kit



8" Rheem Approved Damper Kit



25' Flexible 8" Diameter Duct Kit



Rigid Elbow Duct Kit



UPGRADE KIT (for ProTerra models without LeakGuard only) - Add leak detector and shutoff valve to protect from water damage

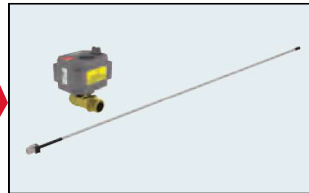

Leak Sensor & Shutoff Valve Kit

In keeping with its policy of continuous progress and product improvement, Rheem reserves the right to make changes without notice.





SANIFLUSH TWO-PIECE ROUND TOILET SYSTEM

Close-Couple Toilet – 1.28 GPF (4.8 Liter Flush)

SANIFLUSH 083 & 005

✓ 083 Round Bowl

- Vitreous china
- Integral P-trap and a rear outlet spigot
- Seating height: 16 ¾" (without seat)
- Large 3" trapway
- Wash down style toilet
- Low flush toilet; it uses 1.28 gallons (4.8 L) per flush
- Toilet supplied with a set of lag screws, plastic anchors and china protectors
- Water spot measures 4 ½" x 3 ¾"
- 1 Year limited warranty

✓ 005 Toilet Tank

- Vitreous china
- Insulated tank to prevent condensation
- The zero re-fill fill valve is easily adjustable
- The flush valve has a silicone flapper seal
- Tank is not designed to be used with refill hose thus not provided.
- Water level mark applied to the overflow tube
- Toilet tank supplied with bowl screws, washers and wing nuts
- 1 year limited warranty
- Warranty for fill and flush valve as per manufacturer

Nominal Dimensions

31" x 17-3/4" x 27"
(787mm x 451mm x 686mm)

Fixture Dimensions and Hydraulic Performance - Meets or Exceeds the Following Specifications

- ANSI/ASME A112.19.2M and CAN/CSA B45 Requirements
- IAPMO/UPC Certificate of Listing
- EPA WaterSense labeled

Notes

- Available in white only
- Includes soft-close toilet seat along with mounting hardware kit Part# SEATROUND
- Replacement fill valve recommended – Fluidmaster 400A or equal (not supplied)



Round Bowl with Tank (083 & 005)

Care & Cleaning

- When cleaning toilet, wash it with mild soapy water or liquid cleaners that are not chlorine or bleach based. Avoid using harsh detergents.
- We do not recommend the use of in-tank cleansers. Products containing chlorine can cause damage to components inside the tank and cause them to fail prematurely.



SFA US3R - 1015



SANIFLUSH TWO-PIECE ROUND TOILET SYSTEM

Close-Couple Toilet – 1.28 GPF (4.8 Liter Flush)

SANIFLUSH 083 & 005

Drawings and Dimensions

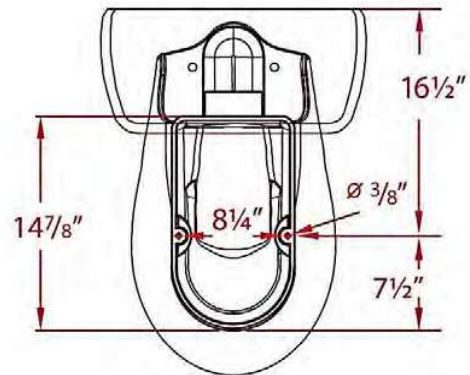
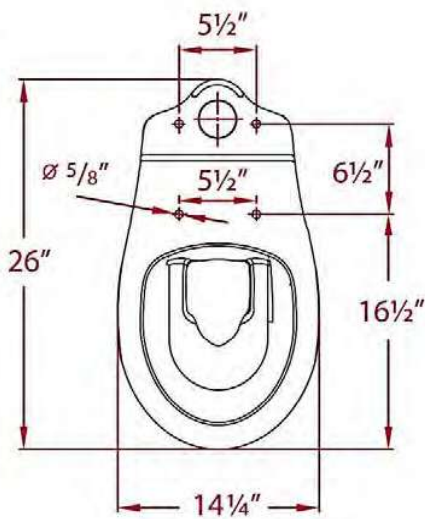
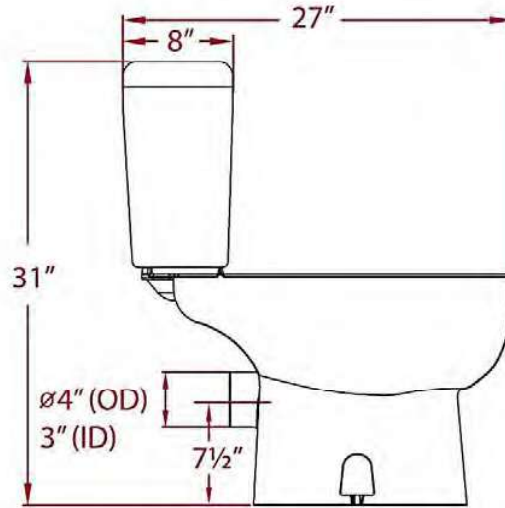
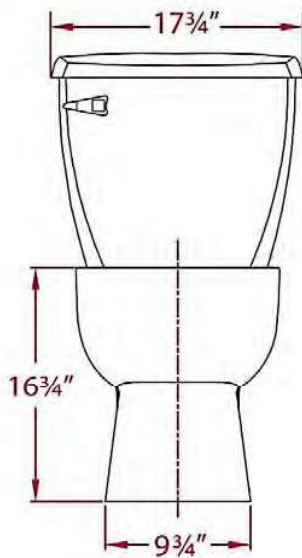

SFA US3R - 1015

SELF-CONTAINED POWER CONNECTORS

Solid Cable Applications

Typical connector applications for the solid cable style connectors include cross-over electrical connections for pre-wired, pre-fabricated/modular structures and homes. With this connector system, manufactured housing OEMs can safely and easily implement modular electrical systems within the structures at the factory and then quickly plug them together at the home site. Additional applications include lighting systems and other construction projects.

Stranded Cable Applications

Typical applications for the stranded cable versions of the connectors include splices and taps used for AC power applications in the marine industry. With the SC Power Connectors, marine OEMs can manufacture discrete modules for staterooms, salons, and galleys and plug them together into the same electrical system as the modules are dropped into the hull further down the manufacturing line. These connectors are similar to the solid cable versions described above. Additional applications include shipboard lighting and other electrical connections that may have required a junction box. A special version of the Self-Contained Power Connector is also available for use with round jacketed, stranded power cable including SEOW/SJEW types. Applications for this version include splice applications used in RV slide-out module manufacturing.

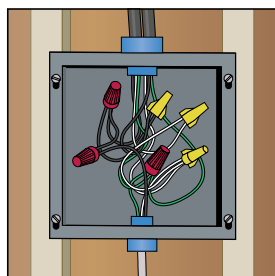

Self-Contained Power Connectors from Molex allow you to easily transition from solid NM cable to SEOW/SJEW type cable

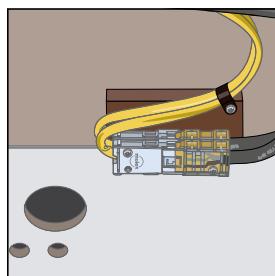

Traditionally procedure involves connecting each wire with a wire nut inside a junction box

Features and Benefits

- A double latching system provides positive connection security, but is fully releaseable so the connector can be mated and remated as needed during the manufacturing process
- Once the connector is closed, the strain relief is automatically set into place so screws and human factors are not a concern
- No special tools required, just pliers
- Markable surface area on housing allows for easy circuit identification, eliminating mis-wiring
- Double insulation displacement contacts provide maximum conductivity and reduce voltage drop
- High impact, crystal clear strain relief cover provides durability and allows for complete visual inspection
- Simple two-piece construction provides for ease of use and eliminates the worry of losing small parts
- UL Listed to be connected and disconnected while under load
- Stranded cable versions are UL Marine Listed
- Hermaphroditic design mates with itself so there is only one part to order and inventory
- Optional dual mounting holes accept screws or nails
- Engineered to meet ABYC, NMMA, and Coast Guard standards.

Reference Information

UL File No.: E182087 (12-16 AWG)

E217798 (10 AWG)

CSA File No.: LR18689-C53

NEC Article: 550-10K and 545-13

HUD Section: 3280.801

Electrical

16-12 AWG version

Current: 20A

Voltage: 300V

10 AWG version

Current: 30A

Voltage: 300V

SELF-CONTAINED POWER CONNECTORS



Two-Circuit Version

The SC Power Splice Connectors are used with solid and stranded nonmetallic sheathed cable. Solid cable versions are available for 14/2, 12/2, and 10/2 wire. Stranded cable versions are available for 16/2, 14/2, 12/2, and 10/2 wire. The connectors are used to wire homes, buildings, office partitions, RV's, motor homes, boats, and many other electrical applications using 110 and 220 AC circuits.

The SC Power Splice Connectors have three contacts that accept the solid or stranded conductors found in a 2-conductor plus ground. Each terminal makes contact with the conductor via insulation displacement (IDT) contacts. They also help to support the conductor and keep it from moving within the connector. Lastly, by having the dual IDT slots, this part operates with virtually no millivolt drop.

Three-Circuit Version

The 3-circuit splice connector can be used to splice solid nonmetallic cable 14/3 and 12/3 with ground. This connector shares all the features, assembly methods and agency approvals as the two circuit versions. It is generally used for the wiring of smoke detectors, 3-way lights and entertainment centers.

Two-Circuit SEOW/SJEW Cable Version

The 2-circuit SEOW/SJEW versions have been specifically engineered to accommodate round jacketed, stranded conductor power cords typically found in RV slide-out manufacturing applications. These products provide a time saving alternative over hard wiring junction boxes. The SEOW/SJEW versions mate with the standard Self-Contained Power Connector products including the tap version, and provide a simple and reliable method for transitioning from solid NM cable to stranded SEOW/SJEW type cable. Designed with the double insulation displacement contact system, the 2-circuit SEOW/SJEW cable versions provide maximum conductivity and minimize resistance associated with voltage drops.

SC Power Series Tap Connectors

The SC Tap Splice is used for splicing into an existing solid conductor 14/2 and 12/2 cable with ground. Stranded wire versions are available for 16/2, 14/2, and 12/2 wire. This provides the user the ability to add an additional branch line or add modular hookups in their products anywhere they are needed. The Molex Tap Splice is relatively small and fits into walls, floors, and ceiling cavities with ease. Once the Tap Connector has been spliced into the cable, the branch line wire to a SC Power Splice Connector can be mated to the Tap.

Weather Tight Boots

Some AC power applications require splices in areas exposed to rain and spray. The Weather Tight Boot product is a two-piece rubber cover which completely encloses the mated SC Power Connector in a splice application.

Self-Contained Power Connector Safety Cap and Dust Cover Safety Cap

The Safety Cap product fits securely over the interface area of an unmated Self-Contained Power Connector Splice, Tap, or Panel Mount Connector. With this product, unmated Self-Contained Connectors can be implemented into designs and remain unmated for future use.

Dust Cover

Dust Covers provide an effective solution for protecting unmated circuits from damage due to dust and dirt accumulation.

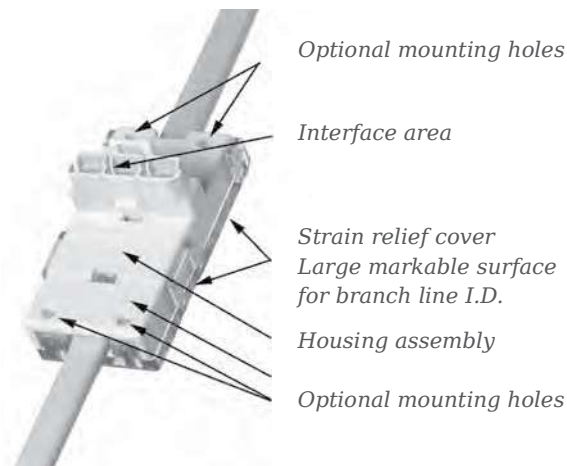

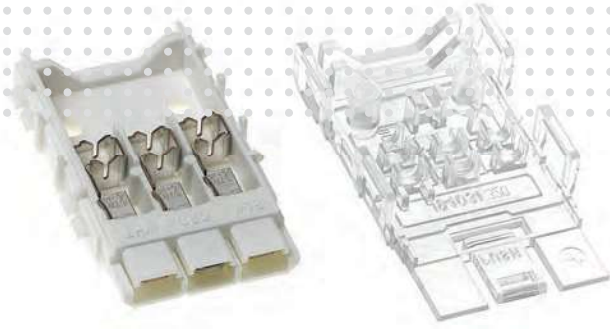

Self-Contained Power Connector - 2-Circuit for Solid Wire

Wire Range (AWG)	Order Number	Housing Color	Optional Hand Tool	Optional Bench Mount Tool	Optional Arbor Press

Self-Contained Power Connector - 2-Circuit for Stranded Wire

Wire Range (AWG)	Order Number	Housing Color	Optional Hand Tool	Optional Bench Mount Tool	Optional Arbor Press

Self-Contained Power Connector - 2-Circuit for Round Stranded Cable

Wire Range (AWG)	Insulation Diameter mm (in.)	Order Number	Housing Color	Cover Color	Optional Hand Tool	Optional Bench Arbor Press

Self-Contained Tap Connector - 2-Circuit for Solid Wire

Wire Range (AWG)	Order Number	Optional Hand Tool	Optional Bench Arbor Press

Self-Contained Power Connector - 3-Circuit

Wire Range (AWG)	Order Number	Housing Color	Optional Hand Tool	Optional Bench Mount Tool	Optional Arbor Press

Weathertight Boots

Wire Range (AWG)	Wire Type	Order Number Male	Order Number Female



Self-Contained Power Connector Safety Cap and Dust Cover

Description	Order Number

Decora® Timer Switches



Automatically Turns Lights Off

Leviton Timer Switches offer advanced features, superior accuracy, and contemporary aesthetics. Our robust selection provides automatic timed control of lighting and motor loads in homes, offices, schools, libraries, and other small commercial applications. An easy upgrade, automatic timers are convenient, help reduce energy costs and improve security.

Set lights to automatically turn on and off at designated times. Our versatile selection includes fully programmable and preset countdown timer switches in popular styles and colors. We also offer smart timers as part of our Decora Smart® line so users can manage, schedule and control lighting anytime, from anywhere using the My Leviton app or their favorite voice assistant. All are backed by Leviton's long history of quality and reliability.

Applications

Porch and landscape lighting, interior lights, bathroom exhaust fans, heat lamps, pool pumps, hot tubs, saunas, attic fans, small closets, basements, garages and more.



Features and Benefits

- Replaces a standard wall switch (neutral required on select models)
- Soothing green LEDs
- Contemporary styling coordinates with Leviton's Decora® wiring devices
- Compatible with Decora Plus™ screwless wallplates

5-Button Decora Countdown Timer Switches

- Four preset buttons and OFF
- Simple press and hold override function
- Leaded terminals for easier installation
- Shallow design easily fits in the wallbox
- Controls LED, CFL, Incandescent, Halogen, Magnetic Low Voltage, Electronic Low Voltage, Fluorescent or Motor loads
- Zero Cross turn-on technology to extend the life of the switching relays
- Additional faceplate colors (DTKIT) available in white, ivory, light almond, gray, black and brown

DT1xx 15 Amp Models

- Available in six options: 15-, 30-, 60-minute and 2-, 4-, 12-hour
- Single pole only
- Flexible wiring can be connected to Neutral wire if present in the wallbox, or Earth ground if no Neutral wire is present
- Interchangeable line and load wires

DT2xx 20 Amp Models

- Available in five options: 30-, 60-minute and 2-, 4-, 12-hour
- Single pole or multi-way when used with a DD0SR Switch Companion, or can be used in 3-way with an additional DT2xx Timer
- Neutral wire required for installation
- Supports larger loads

Decora 24-Hour Programmable Timer Switch

- Timer settings at-a-glance with large, back-lit display
- Flexibility to program weekdays, weekends, or any combination of days
- Astronomical clock automatically adjusts to local sunrise/sunset times
- Automatic daylight saving time adjustment option
- Rechargeable battery keeps time during temporary power outages
- Controls LED, CFL, Incandescent, Halogen, Fluorescent or Motor loads
- Additional faceplate colors (VPTKT) available in gray and black
- VPT24-16Z and VPT24-16W have one-touch temporary override

Agency Standards and Compliance

- Complies with FCC Part 15, Class B
- cCSAus Certified (File # 3413, Class 4823-56 and 4823-86)
- VPT24-16Z and VPT24-16W can be used to comply with California Title 24, Part 6, Residential Outdoor Control Device Requirements

Warranty Information

Five-year limited warranty

Installation Considerations

- DO NOT use to control lighting if it is the only light source in the area

Dimensional Drawings

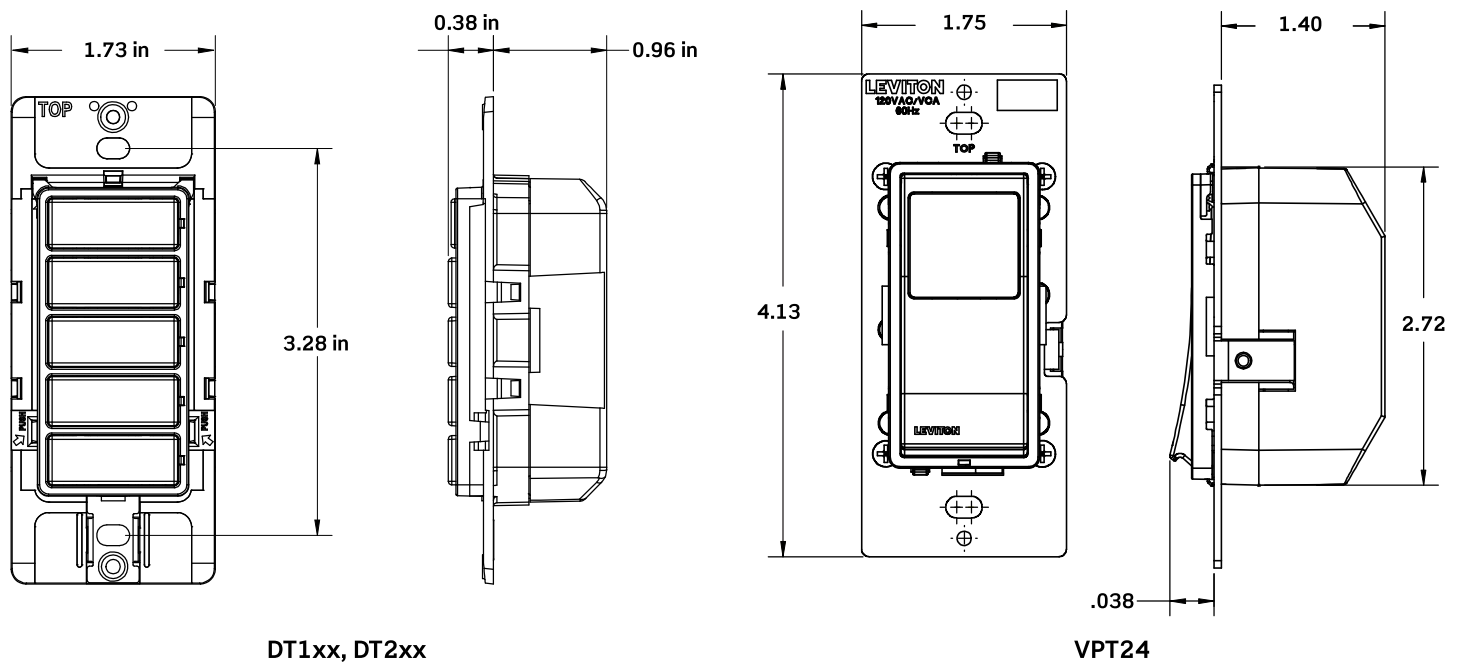

Wiring Diagrams

Cat. Nos. DT1xx

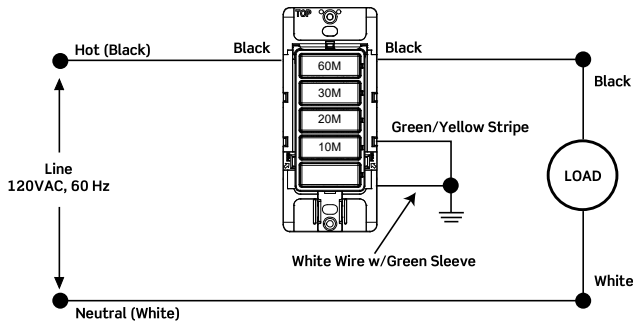

Single Pole, No Neutral Wire

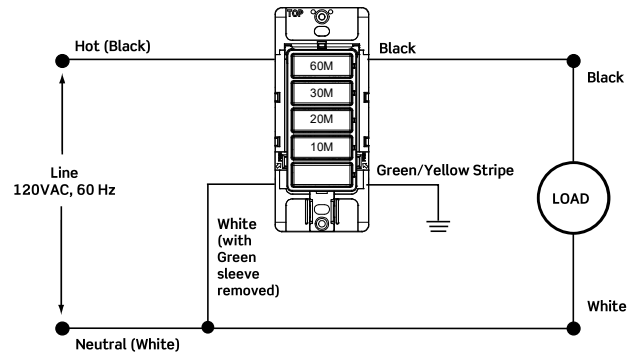

Single Pole, with Neutral Wire

Cat. Nos. DT2xx

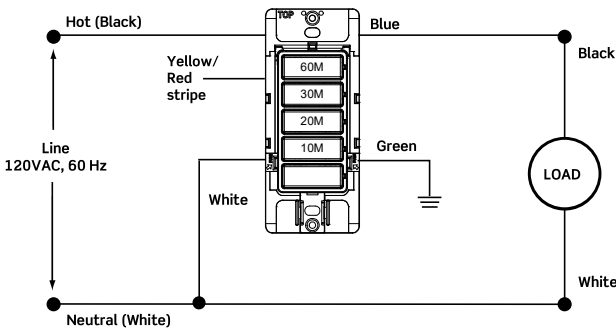

Single Pole, with Neutral Wire

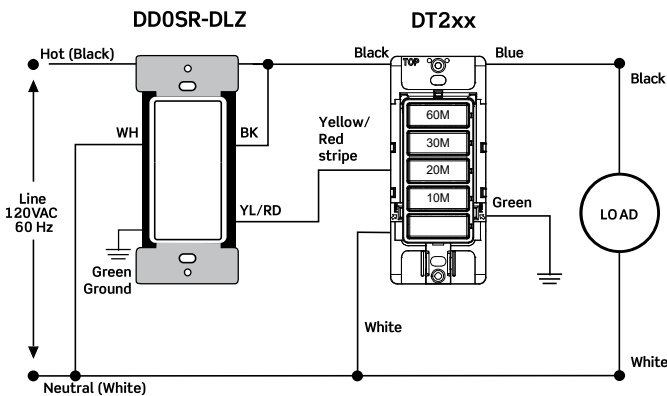

3-Way with Switch Companion
(Up to Four DD0SR-DLZ can be used)

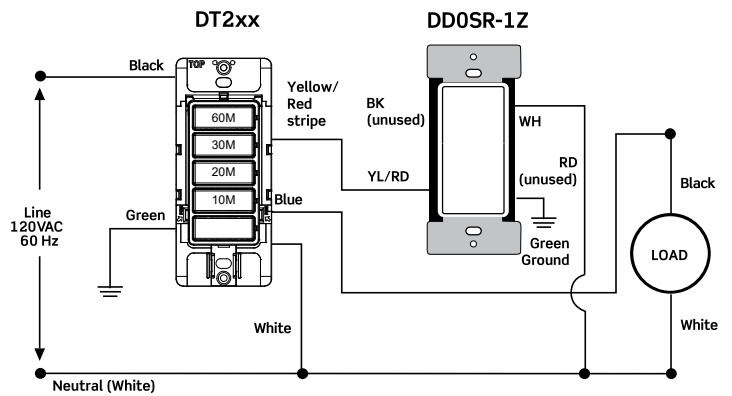

3-Way with Switch Companion, no LED
(Up to Nine DD0SR-1Z can be used)

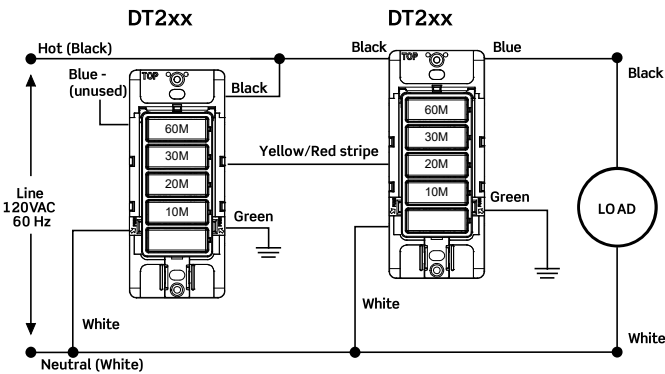

3-Way with Two DT2xx Timers

Wiring Diagrams

Cat. No. VPT24

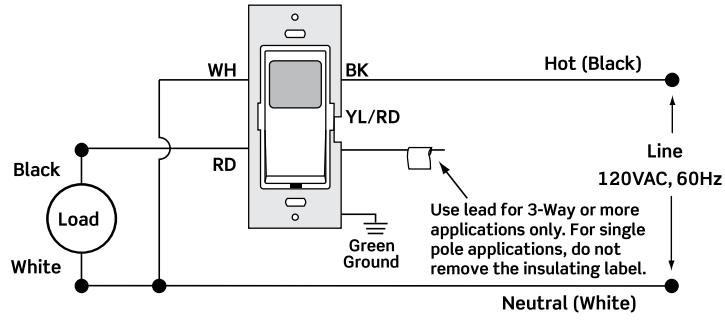

Single Pole with Neutral Wire

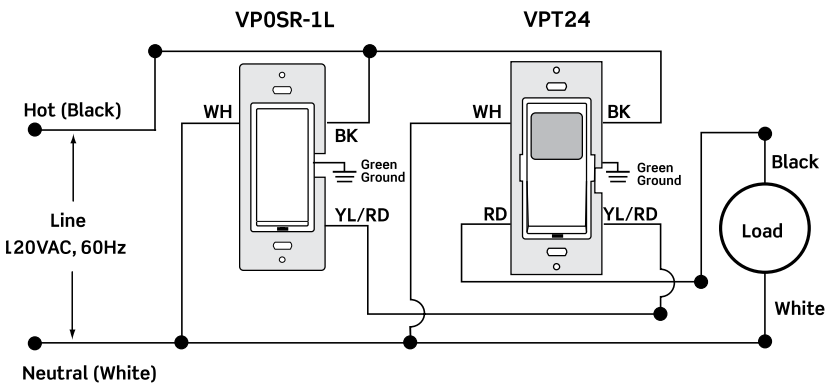

**3-Way with Switch Companion
(up to Four VPOSR-1L can be used)**

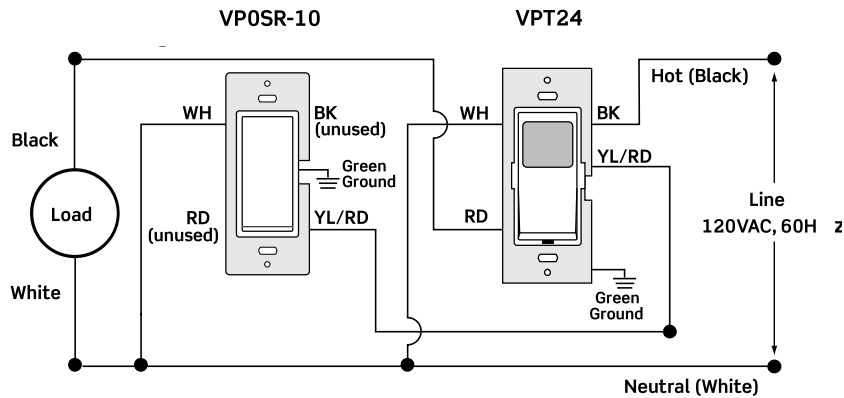

**3-Way with Switch Companion, no LED
(up to Nine VPOSR-10 can be used)**

Specifications At-A-Glance

	DT115	DT130	DT160	DT102	DT104	DT112	DT230	DT260	DT202	DT204	DT212	VPT24
Voltage, frequency 120VAC, 60 Hz	•	•	•	•	•	•	•	•	•	•	•	•
Load Rating												
LED	600W						600W				600W	
CFL	600W						600W				600W	
Incandescent/ Halogen	1800W						1800W				1800W	
MLV	1200VA						1200VA				-	
ELV	1200VA						1200VA				-	
Fluorescent	1200VA						1200VA				15 Amp	
Motor	1/2 hp						1 hp				1 hp	
Resistive/ Inductive	15 Amp Resistive						20 Amp Resistive/15 Amp Inductive				-	
Mechanical												
Wiring Required for Operation	Neutral or Earth ground	Neutral or Earth ground	Neutral or Earth ground	Neutral or Earth ground	Neutral or Earth ground	Neutral or Earth ground	Neutral	Neutral	Neutral	Neutral	Neutral	Neutral
Single Pole (SP), Multi-Way (MW), Multi-Timer (MT)	SP	SP	SP	SP	SP	SP	SP, MW, MT	SP, MW, MT	SP, MW, MT	SP, MW, MT	SP, MW, MT	SP, MW
Countdown or Programmable Timer	Count- down	Count- down	Count- down	Count- down	Count- down	Count- down	Count- down	Count- down	Count- down	Count- down	Count- down	Programmable
Timer Button Options	2-5- 10-15 minutes	5-10- 15-30 minutes	10-20- 30-60 minutes	15-30 min, 1-2 hr	30 min, 1-2-4 hr	2-4-8- 12 hr	5-10- 15-30 minutes	10-20- 30-60 minutes	15-30 min, 1-2 hr	30 min, 1-2-4 hr	2-4-8- 12 hr	24-hr program
Certifications												
cCSAus	•	•	•	•	•	•	•	•	•	•	•	•
CA Title 24 Code Compliance	-	-	-	-	-	-	-	-	-	-	-	•
Environmental												
Operating Temperature 0°C to 40°C	•	•	•	•	•	•	•	•	•	•	•	•
Relative Humidity 0% to 90% non-condensing	•	•	•	•	•	•	•	•	•	•	•	•
Storage Temperature -20°C to 60°C	•	•	•	•	•	•	•	•	•	•	•	•

Ordering Information

Description	Interval	Rating (120VAC, 60Hz)	Cat. No.	Color*
15-Minute Decora 15 Amp Countdown Timer, Single Pole	2-5-10-15 Minutes	600W LED/CFL 1800W Incandescent/Halogen 1200VA ELV/MLV/Fluorescent 1/2 HP Motor 15A Resistive	DT115-1L	W
30-Minute Decora 15 Amp Countdown Timer, Single Pole	5-10-15-30 Minutes		DT130-1L	W, T
60-Minute Decora 15 Amp Countdown Timer, Single Pole	10-20-30-60 Minutes		DT160-1L	W, T
2-Hour Decora 15 Amp Countdown Timer, Single Pole	15-30 Min, 1-2 Hour		DT102-1L	W
4-Hour Decora 15 Amp Countdown Timer, Single Pole	30 Min, 1-2-4 Hour		DT104-1L	W
12-Hour Decora 15 Amp Countdown Timer, Single Pole	2-4-8-12 Hour		DT112-1L	W
30-Minute Decora 20 Amp Countdown Timer, Single Pole or multi-way when used with a DD0SR Switch Companion, or multi-timer with additional DT2xx, neutral required	5-10-15-30 Minutes	600W LED/CFL 1800W Incandescent/Halogen 1200VA ELV/MLV/Fluorescent 1 HP Motor 20A Resistive/15A Inductive	DT230-1L	W
60-Minute Decora 20 Amp Countdown Timer, Single Pole or multi-way when used with a DD0SR Switch Companion, or multi-timer with additional DT2xx, neutral required	10-20-30-60 Minutes		DT260-1L	W
2-Hour Decora 20 Amp Countdown Timer, Single Pole or multi-way when used with a DD0SR Switch Companion, or multi-timer with additional DT2xx, neutral required	15-30 Min, 1-2 Hour		DT202-1L	W
4-Hour Decora 20 Amp Countdown Timer, Single Pole or multi-way when used with a DD0SR Switch Companion, or multi-timer with additional DT2xx, neutral required	30 Min, 1-2-4 Hour		DT204-1L	W
12-Hour Decora 20 Amp Countdown Timer, Single Pole or multi-way when used with a DD0SR Switch Companion, or multi-timer with additional DT2xx, neutral required	2-4-8-12 Hour		DT212-1L	W
Switch Companion for use with 20A Countdown Timer Switch for 3-way or up to 4 additional locations with LED Locator, neutral required	N/A		120V/277V, 60Hz	DD0SR-DL
Switch Companion for use with 20A Countdown Timer Switch for 3-way or up to 9 additional locations, neutral required	N/A	120V, 60Hz	DD0SR-01	Z
Decora 24-Hour Programmable Timer with astronomical clock, neutral required	24-Hour Programmable	600W LED/CFL 1800W Incandescent/Halogen 15A Fluorescent 1 HP Motor	VPT24-1P	Z
Decora 24-Hour Programmable Timer with astronomical clock, neutral required, can be used to comply with California Title 24, Part 6, Residential Outdoor Control Device Requirements			VPT24-16	Z, W
Switch Companion for use with the 24-Hour Programmable Timer Switch for 3-way or up to 4 additional locations with LED Locator, neutral required	N/A	120VAC, 60Hz	VPOSR-1L	Z
Switch Companion for use with the 24-Hour Programmable Timer Switch for 3-way or up to 9 additional locations, neutral required	N/A	120VAC, 60Hz	VPOSR-10	Z

* To order colors, add suffix to basic Cat. No. Products with suffix (-Z) include White, Ivory and Light Almond. Other colors include: White (-W) only. DT130-1L and DT160-1L are available in Light Almond (-T) as special order only.

Faceplate Colors

Description	Cat. No.	Color
Color Change Faceplates for Decora Countdown Timers	DTKIT-00	W, I, T, G, E, B
Color Change Faceplates for Decora 24-Hour Programmable Timer	VPTKT-00	G, E

Color change kits available in the following colors: White (-W), Ivory (-I), Light Almond (-T), Gray (-G), Black (-E), and Brown (-B).



Visit our Website at: www.leviton.com/timers

© 2024 Leviton Manufacturing Co., Inc. All rights reserved.



CONDITION	ALARMAUDIBLE & VISUAL SIGNALS				RECOMMENDATION
	HORN	PWR GREEN LED	SMK RED LED	CO RED LED	
New - Out of package.	Off	Off	Off	Off	To activate the alarm remove the pull tab. The alarm will sound one long beep to let you know it is powered up.
AC power is present. DC power is present.	Silent	Stays On	Blinks On approx. every 2 minutes.	Off	Alarm is operating properly.
Alarm is powered by battery backup. AC power not present.	Silent	Off	Blinks On approx. every 2 minutes.	Off	Check the breaker or fuse box for power. If the breaker or fuse box looks normal, call a licensed electrician for assistance.
The Test button has been pressed. The test sequence lasts for approx. 10 seconds	3 Beeps, 6 second pause, 4 beeps.	Stays On	Blinks On in sync with 3 beeps.	Blinks On in sync with 4 beeps.	Test the alarm following installation and weekly thereafter. The built-in test switch accurately tests the alarm operation as required by ANSI/UL217 and UL2034 Standards for Safety. If, at any time, the alarm does not perform as described during the test, replace it immediately.
One or more alarms not responding to interconnected alarm.	Horn does not sound when other alarms are active or when test button is pressed on interconnected alarm	Stays On	Blinks on approx. every 2 minutes	Off	Press and hold the smoke alarm Test button for at least 5 seconds. If still no alarm, turn off AC Power at the circuit breaker or fuse box and disconnect the alarm from the mounting bracket and make sure the connector plug is securely attached on alarms that did not sound. If still no alarm, have licensed electrician make sure the yellow wire is not mistakenly or accidentally connected to the white (neutral) wire. NOTE: In an interconnected system containing a CO alarm, the CO alarm will not respond to the smoke alarm signal and the smoke alarm will not respond to the CO alarm signal.
Originating Smoke Alarm	3 Beeps, 2 second pause, repeat	Stays On	Blinks on in sync with 3 beeps	Off	If hazard is identified please take all precautions if an alarm sounds by calling an Emergency Service and getting out of the home.
The Test button has been pressed. The test sequence lasts for approx. 10 seconds.	3 Beeps, 6 second pause, 4 beeps.	Stays On	Blinks On in sync with 3 beeps.	Blinks On in sync with 4 beeps.	Test the alarm following installation and weekly thereafter. The built-in test switch accurately tests the alarm operation as required by ANSI/UL217 and UL2034 Standards for Safety. If, at any time, the alarm does not perform as described during the test, replace it immediately.
One or more alarms not responding to interconnected alarm.	Horn does not sound when other alarms are active or when test button is pressed on interconnected alarm	Stays On	Blinks on approx. every 2 minutes	Off	Press and hold the smoke alarm Test button for at least 5 seconds. If still no alarm, turn off AC Power at the circuit breaker or fuse box and disconnect the alarm from the mounting bracket and make sure the connector plug is securely attached on alarms that did not sound. If still no alarm, have licensed electrician make sure the yellow wire is not mistakenly or accidentally connected to the white (neutral) wire. NOTE: In an interconnected system containing a CO alarm, the CO alarm will not respond to the smoke alarm signal and the smoke alarm will not respond to the CO alarm signal.
Originating Smoke Alarm	3 Beeps, 2 second pause, repeat	Stays On	Blinks on in sync with 3 beeps	Off	If hazard is identified please take all precautions if an alarm sounds by calling an Emergency Service and getting out of the home.
THIS PRODUCT IS LISTED TO UL STANDARD FOR SAFETY, UL 217 and UL 2034					